



INSTALLATION & OWNER'S MANUAL

Multi Hybrid HR -Outdoor Unit

KAM3HR-52 DR8
KAM4HR-80 DR8



IMPORTANT NOTE:

Read this manual carefully before installing or operating your new appliance. Make sure to save this manual for future reference.

CONTENTS

SAFETY PRECAUTIONS	02
SPECIFICATIONS	09

Installation Instructions

PRODUCT INSTALLATION	12
REFRIGERANT PIPING CONNECTION	20
WIRING PRECAUTIONS	23
AIR EVACUATION	27
NOTE ON ADDING REFRIGERANT	28
TRIAL-RUNNING	30
CONFIGURATION	31

Operation Instructions

OPERATION INSTRUCTIONS	34
MANUAL OPERATIONS & MAINTENANCE	36
TROUBLESHOOTING	37

Read this manual

Inside you'll find many helpful hints on how to use and maintain your appliance properly. Just a little preventive care on your part can save you a great deal of time and money over the life of your appliance. These instructions may not cover every possible condition of use, so common sense and attention to safety is required when installing, operating and maintaining this product.

SAFETY PRECAUTIONS

It's really important you read Safety Precautions Before Operation and Installation. Incorrect installation due to ignoring instructions can cause serious damage or injury. The seriousness of potential damage or injuries is classified as either a **WARNING** or **CAUTION**.

Explanation of Symbols



WARNING

The signal word indicates a hazard with a medium level of risk which, if not avoided, may result in serious injury.



CAUTION

The signal word indicates a hazard with a low degree of risk which, if not avoided, may result in minor or moderate injury.

Read these operating instructions carefully and attentively before using/commis-sioning the unit and keep them in the immediate vicinity of the installation site or unit for later use! Latest revisions of the supplied documentation may be available on the regional Local Dealer Website. The original documentation is written in English. All other languages are translations.

WARNING

- This appliance can be used by children aged from 8 years and above and persons with reduced physical, sensory or mental capabilities or lack of experience and knowledge if they have been given supervision or instruction concerning use of the appliance in a safe way and understand the hazards involved. Children shall not play with the appliance. Cleaning and user maintenance shall not be made by children without supervision (European Union countries).
- This appliance is not intended for use by persons (including children) with reduced physical, sensory or mental capabilities, or lack of experience and knowledge, unless they have been given supervision or instruction concerning use of the appliance by a person responsible for their safety. Children should be supervised to ensure that they do not play with the appliance.
- Make sure installation, servicing, maintenance, repair and applied materials follow the instructions from local distributors and, in addition, comply with applicable legislation and are performed by qualified persons only. In Europe and areas where IEC standards apply, EN/IEC 60335-2-40 is the applicable standard.

CAUTION

- This appliance is intended to be used by expert or trained users in shops, in light industry, and on farms, or for commercial and household use by lay persons.
- This document only describes installation instructions specific to the outdoor unit. For installation of the indoor unit (mounting the indoor unit, connecting the refrigerant piping to the indoor unit, connecting the electrical wiring to the indoor unit ...), see the installation manual of the indoor unit.
- **CAUTION:** In order to avoid a hazard due to inadvertent resetting of the thermal cut-out, this appliance must not be supplied through an external switching device, such as a timer, or connected to a circuit that is regularly switched on and off by the utility.

⚠ WARNING FOR PRODUCT USE

- If an abnormal situation arises (like a burning smell), immediately turn off the unit and disconnect the power. Call your dealer for instructions to avoid electric shock, fire or injury.
- Do not insert fingers, rods or other objects into the air inlet or outlet. This may cause injury, since the fan may be rotating at high speeds.
- Do not use flammable sprays such as hair spray, lacquer or paint near the unit. This may cause fire or combustion.
- Do not operate the air conditioner in places near or around combustible gases. Emitted gas may collect around the unit and cause explosion.
- Do not operate your air conditioner in a wet room such as a bathroom or laundry room. Too much exposure to water can cause electrical components to short circuit.
- Do not expose your body directly to cool air for a prolonged period of time.
- Do not allow children to play with the air conditioner. Children must be supervised around the unit at all times.
- If the air conditioner is used together with burners or other heating devices, thoroughly ventilate the room to avoid oxygen deficiency.
- In certain functional environments, such as kitchens, server rooms, etc., the use of specially designed air-conditioning units is highly recommended.

⚠ ELECTRICAL WARNINGS

- Only use the specified power cord. If the power cord is damaged, it must be replaced by the manufacturer, its service agent or similarly qualified persons in order to avoid a hazard.
- The product must be properly grounded at the time of installation, or electrical shock may occur.
- For all electrical work, follow all local and national wiring standards, regulations, and the Installation Manual. Connect cables tightly, and clamp them securely to prevent external forces from damaging the terminal. Improper electrical connections can overheat and cause fire, and may also cause shock. All electrical connections must be made according to the Electrical Connection Diagram located on the panels of the indoor and outdoor units.
- All wiring must be properly arranged to ensure that the control board cover can close properly. If the control board cover is not closed properly, it can lead to corrosion and cause the connection points on the terminal to heat up, catch fire, or cause electrical shock.
- Disconnection must be incorporated in the fixed wiring in accordance with the wiring rules.
- Do not pull power cord to unplug unit. Hold the plug firmly and pull it from the outlet. Pulling directly on the cord can damage it, which can lead to fire or electric shock.
- Do not modify the length of the power supply cord or use an extension cord to power the unit.
- Do not share the electrical outlet with other appliances. Improper or insufficient power supply can cause fire or electrical shock.
- Keep power plug clean. Remove any dust or grime that accumulates on or around the plug. Dirty plugs can cause fire or electric shock.
- If connecting power to fixed wiring, an all-pole disconnection device which has at least 3mm clearances in all poles, and have a leakage current that may exceed 10mA, the residual current device (RCD) having a rated residual operating current not exceeding 30mA, and disconnection must be incorporated in the fixed wiring in accordance with the wiring rules.

- The fixed wiring insulation must be protected, for example, by insulating sleeving having an appropriate temperature rating.

TAKE NOTE OF FUSE SPECIFICATIONS

The air conditioner's circuit board (PCB) is designed with a fuse to provide overcurrent protection. The specifications of the fuse are printed on the circuit board, such as: T20A/250VAC (for <24000Btu/h unit), T30A/250VAC (for >24000Btu/h unit)

NOTE: For the units with R32 refrigerant, only the blast-proof ceramic fuse can be used.

⚠ WARNINGS FOR PRODUCT INSTALLATION

- Installation must be performed by an authorized dealer or specialist. Defective installation can cause water leakage, electrical shock, or fire.
- Installation must be performed according to the installation instructions. Improper installation can cause water leakage, electrical shock, or fire.
- Contact an authorized service technician for repair or maintenance of this unit. This appliance shall be installed in accordance with national wiring regulations.
- Only use the included accessories, parts, and specified parts for installation. Using non-standard parts can cause water leakage, electrical shock, fire, and can cause the unit to fail.
- Install the unit in a firm location that can support the unit's weight. If the chosen location cannot support the unit's weight, or the installation is not done properly, the unit may drop and cause serious injury and damage.
- Install drainage piping according to the instructions in this manual. Improper drainage may cause water damage to your home and property.
- For units that have an auxiliary electric heater, do not install the unit within 1 meter (3 feet) of any combustible materials.
- Do not install the unit in a location that may be exposed to combustible gas leaks. If combustible gas accumulates around the unit, it may cause fire.
- Do not turn on the power until all work has been completed.
- When moving or relocating the air conditioner, consult experienced service technicians for disconnection and reinstallation of the unit.
- How to install the appliance to its support, please read the information for details in "indoor unit installation" and "outdoor unit installation" sections.
- Ducts connected to an appliance shall not contain a potential ignition source.
- The outdoor unit can be anchored to the ground or to a wall-mounted bracket with bolt (M10).

⚠ CAUTION

- Turn off the air conditioner and disconnect the power if you are not going to use it for a long time (when the ambient temperature in which the water tank is located is below 0°C, please empty the water in the tank to avoid freezing that may cause damage to the tank.).
- Turn off and unplug the unit during storms.
- Make sure that water condensation can drain unhindered from the unit.
- Do not operate the air conditioner with wet hands. This may cause electric shock.
- Do not use device for any other purpose than its intended use.
- Do not climb onto or place objects on top of the outdoor unit.
- Do not allow the air conditioner to operate for long periods of time with doors or windows open, or if the humidity is very high.

⚠ WARNING FOR USING R32 REFRIGERANT

- When flammable refrigerant is employed, appliance shall be stored in a well-ventilated area where the room size corresponds to the room area as specific for operation.

(1) Water tanks shall be installed, operated and stored in a room with a floor area larger than:

Below requirements apply to standards EN IEC 60335-2-40: 2023 and IEC 60335-2-40: 2018 and the amendment or upgraded versions of both.

Floor standing or wall mounted water tanks with an installation height of less than 0.8 meters. (Excluding 0.8 meters)			
m(kg)——Amin(m ²)	m(kg)——Amin(m ²)	m(kg)——Amin(m ²)	m(kg)——Amin(m ²)
m ≤ 1.84 ——/	2.60 < m ≤ 2.65 ——59.77	3.40 < m ≤ 3.45 ——101.31	4.20 < m ≤ 4.25 ——153.73
1.84 < m ≤ 1.90 ——30.73	2.65 < m ≤ 2.70 ——62.05	3.45 < m ≤ 3.50 ——104.26	4.25 < m ≤ 4.30 ——157.37
1.90 < m ≤ 1.95 ——32.37	2.70 < m ≤ 2.75 ——64.37	3.50 < m ≤ 3.55 ——107.26	4.30 < m ≤ 4.35 ——161.05
1.95 < m ≤ 2.00 ——34.05	2.75 < m ≤ 2.80 ——66.73	3.55 < m ≤ 3.60 ——110.31	4.35 < m ≤ 4.40 ——164.77
2.00 < m ≤ 2.05 ——35.77	2.80 < m ≤ 2.85 ——69.13	3.60 < m ≤ 3.65 ——113.39	4.40 < m ≤ 4.45 ——168.54
2.05 < m ≤ 2.10 ——37.54	2.85 < m ≤ 2.90 ——71.58	3.65 < m ≤ 3.70 ——116.52	4.45 < m ≤ 4.50 ——172.35
2.10 < m ≤ 2.15 ——39.35	2.90 < m ≤ 2.95 ——74.07	3.70 < m ≤ 3.75 ——119.69	4.50 < m ≤ 4.55 ——176.20
2.15 < m ≤ 2.20 ——41.20	2.95 < m ≤ 3.00 ——76.60	3.75 < m ≤ 3.80 ——122.90	4.55 < m ≤ 4.60 ——180.09
2.20 < m ≤ 2.25 ——43.09	3.00 < m ≤ 3.05 ——79.18	3.80 < m ≤ 3.85 ——126.16	4.60 < m ≤ 4.65 ——184.03
2.25 < m ≤ 2.30 ——45.03	3.05 < m ≤ 3.10 ——81.79	3.85 < m ≤ 3.90 ——129.45	4.65 < m ≤ 4.70 ——188.01
2.30 < m ≤ 2.35 ——47.01	3.10 < m ≤ 3.15 ——84.45	3.90 < m ≤ 3.95 ——132.80	4.70 < m ≤ 4.75 ——192.03
2.35 < m ≤ 2.40 ——49.03	3.15 < m ≤ 3.20 ——87.16	3.95 < m ≤ 4.00 ——136.18	4.75 < m ≤ 4.80 ——196.09
2.40 < m ≤ 2.45 ——51.09	3.20 < m ≤ 3.25 ——89.90	4.00 < m ≤ 4.05 ——139.60	4.80 < m ≤ 4.85 ——200.20
2.45 < m ≤ 2.50 ——53.20	3.25 < m ≤ 3.30 ——92.69	4.05 < m ≤ 4.10 ——143.07	4.85 < m ≤ 4.90 ——204.35
2.50 < m ≤ 2.55 ——55.35	3.30 < m ≤ 3.35 ——95.52	4.10 < m ≤ 4.15 ——146.58	4.90 < m ≤ 4.95 ——208.54
2.55 < m ≤ 2.60 ——57.54	3.35 < m ≤ 3.40 ——98.39	4.15 < m ≤ 4.20 ——150.14	4.95 < m ≤ 5.00 ——212.78

Install wall mounted water tanks with a height greater than or equal to 0.8 meters and less than 1.0 meters. (Excluding 1.0 meters)			
m(kg)——Amin(m ²)	m(kg)——Amin(m ²)	m(kg)——Amin(m ²)	m(kg)——Amin(m ²)
m ≤ 1.84 ——/	2.60 < m ≤ 2.65 ——33.62	3.40 < m ≤ 3.45 ——56.99	4.20 < m ≤ 4.25 ——86.48
1.84 < m ≤ 1.90 ——17.29	2.65 < m ≤ 2.70 ——34.90	3.45 < m ≤ 3.50 ——58.65	4.25 < m ≤ 4.30 ——88.52
1.90 < m ≤ 1.95 ——18.21	2.70 < m ≤ 2.75 ——36.21	3.50 < m ≤ 3.55 ——60.34	4.30 < m ≤ 4.35 ——90.59
1.95 < m ≤ 2.00 ——19.15	2.75 < m ≤ 2.80 ——37.54	3.55 < m ≤ 3.60 ——62.05	4.35 < m ≤ 4.40 ——92.69
2.00 < m ≤ 2.05 ——20.12	2.80 < m ≤ 2.85 ——38.89	3.60 < m ≤ 3.65 ——63.78	4.40 < m ≤ 4.45 ——94.81
2.05 < m ≤ 2.10 ——21.12	2.85 < m ≤ 2.90 ——40.27	3.65 < m ≤ 3.70 ——65.54	4.45 < m ≤ 4.50 ——96.95
2.10 < m ≤ 2.15 ——22.13	2.90 < m ≤ 2.95 ——41.67	3.70 < m ≤ 3.75 ——67.33	4.50 < m ≤ 4.55 ——99.11
2.15 < m ≤ 2.20 ——23.18	2.95 < m ≤ 3.00 ——43.09	3.75 < m ≤ 3.80 ——69.13	4.55 < m ≤ 4.60 ——101.31
2.20 < m ≤ 2.25 ——24.24	3.00 < m ≤ 3.05 ——44.54	3.80 < m ≤ 3.85 ——70.97	4.60 < m ≤ 4.65 ——103.52
2.25 < m ≤ 2.30 ——25.33	3.05 < m ≤ 3.10 ——46.01	3.85 < m ≤ 3.90 ——72.82	4.65 < m ≤ 4.70 ——105.76
2.30 < m ≤ 2.35 ——26.44	3.10 < m ≤ 3.15 ——47.51	3.90 < m ≤ 3.95 ——74.70	4.70 < m ≤ 4.75 ——108.02
2.35 < m ≤ 2.40 ——27.58	3.15 < m ≤ 3.20 ——49.03	3.95 < m ≤ 4.00 ——76.60	4.75 < m ≤ 4.80 ——110.31
2.40 < m ≤ 2.45 ——28.74	3.20 < m ≤ 3.25 ——50.57	4.00 < m ≤ 4.05 ——78.53	4.80 < m ≤ 4.85 ——112.62
2.45 < m ≤ 2.50 ——29.93	3.25 < m ≤ 3.30 ——52.14	4.05 < m ≤ 4.10 ——80.48	4.85 < m ≤ 4.90 ——114.95
2.50 < m ≤ 2.55 ——31.13	3.30 < m ≤ 3.35 ——53.73	4.10 < m ≤ 4.15 ——82.45	4.90 < m ≤ 4.95 ——117.31
2.55 < m ≤ 2.60 ——32.37	3.35 < m ≤ 3.40 ——55.35	4.15 < m ≤ 4.20 ——84.45	4.95 < m ≤ 5.00 ——119.69

Install wall mounted water tanks with a height greater than or equal to 1.0 meters and less than 1.3 meters.(Excluding 1.3meters)			
m(kg)——Amin(m ²)	m(kg)——Amin(m ²)	m(kg)——Amin(m ²)	m(kg)——Amin(m ²)
m ≤ 1.84 ——/	2.60 < m ≤ 2.65 ——21.52	3.40 < m ≤ 3.45 ——36.47	4.20 < m ≤ 4.25 ——55.35
1.84 < m ≤ 1.90 ——11.07	2.65 < m ≤ 2.70 ——22.34	3.45 < m ≤ 3.50 ——37.54	4.25 < m ≤ 4.30 ——56.66
1.90 < m ≤ 1.95 ——11.66	2.70 < m ≤ 2.75 ——23.18	3.50 < m ≤ 3.55 ——38.62	4.30 < m ≤ 4.35 ——57.98
1.95 < m ≤ 2.00 ——12.26	2.75 < m ≤ 2.80 ——24.03	3.55 < m ≤ 3.60 ——39.71	4.35 < m ≤ 4.40 ——59.32
2.00 < m ≤ 2.05 ——12.88	2.80 < m ≤ 2.85 ——24.89	3.60 < m ≤ 3.65 ——40.82	4.40 < m ≤ 4.45 ——60.68
2.05 < m ≤ 2.10 ——13.52	2.85 < m ≤ 2.90 ——25.77	3.65 < m ≤ 3.70 ——41.95	4.45 < m ≤ 4.50 ——62.05
2.10 < m ≤ 2.15 ——14.17	2.90 < m ≤ 2.95 ——26.67	3.70 < m ≤ 3.75 ——43.09	4.50 < m ≤ 4.55 ——63.44
2.15 < m ≤ 2.20 ——14.83	2.95 < m ≤ 3.00 ——27.58	3.75 < m ≤ 3.80 ——44.25	4.55 < m ≤ 4.60 ——64.84
2.20 < m ≤ 2.25 ——15.52	3.00 < m ≤ 3.05 ——28.51	3.80 < m ≤ 3.85 ——45.42	4.60 < m ≤ 4.65 ——66.25
2.25 < m ≤ 2.30 ——16.21	3.05 < m ≤ 3.10 ——29.45	3.85 < m ≤ 3.90 ——46.61	4.65 < m ≤ 4.70 ——67.69
2.30 < m ≤ 2.35 ——16.93	3.10 < m ≤ 3.15 ——30.41	3.90 < m ≤ 3.95 ——47.81	4.70 < m ≤ 4.75 ——69.13
2.35 < m ≤ 2.40 ——17.65	3.15 < m ≤ 3.20 ——31.38	3.95 < m ≤ 4.00 ——49.03	4.75 < m ≤ 4.80 ——70.60
2.40 < m ≤ 2.45 ——18.40	3.20 < m ≤ 3.25 ——32.37	4.00 < m ≤ 4.05 ——50.26	4.80 < m ≤ 4.85 ——72.08
2.45 < m ≤ 2.50 ——19.15	3.25 < m ≤ 3.30 ——33.37	4.05 < m ≤ 4.10 ——51.51	4.85 < m ≤ 4.90 ——73.57
2.50 < m ≤ 2.55 ——19.93	3.30 < m ≤ 3.35 ——34.39	4.10 < m ≤ 4.15 ——52.77	4.90 < m ≤ 4.95 ——75.08
2.55 < m ≤ 2.60 ——20.72	3.35 < m ≤ 3.40 ——35.42	4.15 < m ≤ 4.20 ——54.05	4.95 < m ≤ 5.00 ——76.60

Install wall mounted water tanks with a height greater than or equal to 1.3 meters			
m(kg)——Amin(m ²)	m(kg)——Amin(m ²)	m(kg)——Amin(m ²)	m(kg)——Amin(m ²)
m ≤ 1.84 ——/	2.60 < m ≤ 2.65 ——12.74	3.40 < m ≤ 3.45 ——21.58	4.20 < m ≤ 4.25 ——32.75
1.84 < m ≤ 1.90 ——6.55	2.65 < m ≤ 2.70 ——13.22	3.45 < m ≤ 3.50 ——22.21	4.25 < m ≤ 4.30 ——33.53
1.90 < m ≤ 1.95 ——6.90	2.70 < m ≤ 2.75 ——13.72	3.50 < m ≤ 3.55 ——22.85	4.30 < m ≤ 4.35 ——34.31
1.95 < m ≤ 2.00 ——7.26	2.75 < m ≤ 2.80 ——14.22	3.55 < m ≤ 3.60 ——23.50	4.35 < m ≤ 4.40 ——35.10
2.00 < m ≤ 2.05 ——7.62	2.80 < m ≤ 2.85 ——14.73	3.60 < m ≤ 3.65 ——24.16	4.40 < m ≤ 4.45 ——35.91
2.05 < m ≤ 2.10 ——8.00	2.85 < m ≤ 2.90 ——15.25	3.65 < m ≤ 3.70 ——24.82	4.45 < m ≤ 4.50 ——36.72
2.10 < m ≤ 2.15 ——8.39	2.90 < m ≤ 2.95 ——15.78	3.70 < m ≤ 3.75 ——25.50	4.50 < m ≤ 4.55 ——37.54
2.15 < m ≤ 2.20 ——8.78	2.95 < m ≤ 3.00 ——16.32	3.75 < m ≤ 3.80 ——26.18	4.55 < m ≤ 4.60 ——38.37
2.20 < m ≤ 2.25 ——9.18	3.00 < m ≤ 3.05 ——16.87	3.80 < m ≤ 3.85 ——26.88	4.60 < m ≤ 4.65 ——39.21
2.25 < m ≤ 2.30 ——9.60	3.05 < m ≤ 3.10 ——17.43	3.85 < m ≤ 3.90 ——27.58	4.65 < m ≤ 4.70 ——40.05
2.30 < m ≤ 2.35 ——10.02	3.10 < m ≤ 3.15 ——17.99	3.90 < m ≤ 3.95 ——28.29	4.70 < m ≤ 4.75 ——40.91
2.35 < m ≤ 2.40 ——10.45	3.15 < m ≤ 3.20 ——18.57	3.95 < m ≤ 4.00 ——29.01	4.75 < m ≤ 4.80 ——41.78
2.40 < m ≤ 2.45 ——10.89	3.20 < m ≤ 3.25 ——19.15	4.00 < m ≤ 4.05 ——29.74	4.80 < m ≤ 4.85 ——42.65
2.45 < m ≤ 2.50 ——11.34	3.25 < m ≤ 3.30 ——19.75	4.05 < m ≤ 4.10 ——30.48	4.85 < m ≤ 4.90 ——43.53
2.50 < m ≤ 2.55 ——11.79	3.30 < m ≤ 3.35 ——20.35	4.10 < m ≤ 4.15 ——31.23	4.90 < m ≤ 4.95 ——44.43
2.55 < m ≤ 2.60 ——12.26	3.35 < m ≤ 3.40 ——20.96	4.15 < m ≤ 4.20 ——31.99	4.95 < m ≤ 5.00 ——45.33

(2) Air conditioning indoor unit shall be installed, operated and stored in a room with a floor area larger than:
 Below requirements apply to standards EN 60335-2-40: 2003 and IEC 60335-2-40: 2013 and the amendment versions of both.

Floor mounted (0.6m)			
m(kg)——Amin(m ²)	m(kg)——Amin(m ²)	m(kg)——Amin(m ²)	m(kg)——Amin(m ²)
m ≤ 1.22 —— 4.00	2.15 < m ≤ 2.20 —— 41.53	3.15 < m ≤ 3.20 —— 87.87	4.15 < m ≤ 4.20 —— 151.37
1.22 < m ≤ 1.25 —— 13.41	2.20 < m ≤ 2.25 —— 43.44	3.20 < m ≤ 3.25 —— 90.64	4.20 < m ≤ 4.25 —— 154.99
1.25 < m ≤ 1.30 —— 14.51	2.25 < m ≤ 2.30 —— 45.40	3.25 < m ≤ 3.30 —— 93.45	4.25 < m ≤ 4.30 —— 158.66
1.30 < m ≤ 1.35 —— 15.64	2.30 < m ≤ 2.35 —— 47.39	3.30 < m ≤ 3.35 —— 96.30	4.30 < m ≤ 4.35 —— 162.37
1.35 < m ≤ 1.40 —— 16.82	2.35 < m ≤ 2.40 —— 49.43	3.35 < m ≤ 3.40 —— 99.20	4.35 < m ≤ 4.40 —— 166.12
1.40 < m ≤ 1.45 —— 18.05	2.40 < m ≤ 2.45 —— 51.51	3.40 < m ≤ 3.45 —— 102.13	4.40 < m ≤ 4.45 —— 169.92
1.45 < m ≤ 1.50 —— 19.31	2.45 < m ≤ 2.50 —— 53.63	3.45 < m ≤ 3.50 —— 105.12	4.45 < m ≤ 4.50 —— 173.76
1.50 < m ≤ 1.55 —— 20.62	2.50 < m ≤ 2.55 —— 55.80	3.50 < m ≤ 3.55 —— 108.14	4.50 < m ≤ 4.55 —— 177.64
1.55 < m ≤ 1.60 —— 21.97	2.55 < m ≤ 2.60 —— 58.01	3.55 < m ≤ 3.60 —— 111.21	4.55 < m ≤ 4.60 —— 181.57
1.60 < m ≤ 1.65 —— 23.37	2.60 < m ≤ 2.65 —— 60.26	3.60 < m ≤ 3.65 —— 114.32	4.60 < m ≤ 4.65 —— 185.54
1.65 < m ≤ 1.70 —— 24.80	2.65 < m ≤ 2.70 —— 62.56	3.65 < m ≤ 3.70 —— 117.47	4.65 < m ≤ 4.70 —— 189.55
1.70 < m ≤ 1.75 —— 26.28	2.70 < m ≤ 2.75 —— 64.90	3.70 < m ≤ 3.75 —— 120.67	4.70 < m ≤ 4.75 —— 193.60
1.75 < m ≤ 1.80 —— 27.81	2.75 < m ≤ 2.80 —— 67.28	3.75 < m ≤ 3.80 —— 123.91	4.75 < m ≤ 4.80 —— 197.70
1.80 < m ≤ 1.85 —— 29.37	2.80 < m ≤ 2.85 —— 69.70	3.80 < m ≤ 3.85 —— 127.19	4.80 < m ≤ 4.85 —— 201.84
1.85 < m ≤ 1.90 —— 30.98	2.85 < m ≤ 2.90 —— 72.17	3.85 < m ≤ 3.90 —— 130.51	4.85 < m ≤ 4.90 —— 206.02
1.90 < m ≤ 1.95 —— 32.63	2.90 < m ≤ 2.95 —— 74.68	3.90 < m ≤ 3.95 —— 133.88	4.90 < m ≤ 4.95 —— 210.25
1.95 < m ≤ 2.00 —— 34.33	2.95 < m ≤ 3.00 —— 77.23	3.95 < m ≤ 4.00 —— 137.29	4.95 < m ≤ 5.00 —— 214.52
2.00 < m ≤ 2.05 —— 36.06	3.00 < m ≤ 3.05 —— 79.83	4.00 < m ≤ 4.05 —— 140.75	
2.05 < m ≤ 2.10 —— 37.85	3.05 < m ≤ 3.10 —— 82.46	4.05 < m ≤ 4.10 —— 144.24	
2.10 < m ≤ 2.15 —— 39.67	3.10 < m ≤ 3.15 —— 85.15	4.10 < m ≤ 4.15 —— 147.78	

Wall mounted (1.8m)			
m(kg)——Amin(m ²)	m(kg)——Amin(m ²)	m(kg)——Amin(m ²)	m(kg)——Amin(m ²)
m ≤ 1.22 —— 4.00	2.90 < m ≤ 2.95 —— 8.30	3.90 < m ≤ 3.95 —— 14.88	4.90 < m ≤ 4.95 —— 23.37
1.22 < m ≤ 2.00 —— 4.00	2.95 < m ≤ 3.00 —— 8.59	3.95 < m ≤ 4.00 —— 15.26	4.95 < m ≤ 5.00 —— 23.84
2.00 < m ≤ 2.05 —— 4.01	3.00 < m ≤ 3.05 —— 8.87	4.00 < m ≤ 4.05 —— 15.64	
2.05 < m ≤ 2.10 —— 4.21	3.05 < m ≤ 3.10 —— 9.17	4.05 < m ≤ 4.10 —— 16.03	
2.10 < m ≤ 2.15 —— 4.41	3.10 < m ≤ 3.15 —— 9.47	4.10 < m ≤ 4.15 —— 16.42	
2.15 < m ≤ 2.20 —— 4.62	3.15 < m ≤ 3.20 —— 9.77	4.15 < m ≤ 4.20 —— 16.82	
2.20 < m ≤ 2.25 —— 4.83	3.20 < m ≤ 3.25 —— 10.08	4.20 < m ≤ 4.25 —— 17.23	
2.25 < m ≤ 2.30 —— 5.05	3.25 < m ≤ 3.30 —— 10.39	4.25 < m ≤ 4.30 —— 17.63	
2.30 < m ≤ 2.35 —— 5.27	3.30 < m ≤ 3.35 —— 10.70	4.30 < m ≤ 4.35 —— 18.05	
2.35 < m ≤ 2.40 —— 5.50	3.35 < m ≤ 3.40 —— 11.03	4.35 < m ≤ 4.40 —— 18.46	
2.40 < m ≤ 2.45 —— 5.73	3.40 < m ≤ 3.45 —— 11.35	4.40 < m ≤ 4.45 —— 18.88	
2.45 < m ≤ 2.50 —— 5.96	3.45 < m ≤ 3.50 —— 11.68	4.45 < m ≤ 4.50 —— 19.31	
2.50 < m ≤ 2.55 —— 6.20	3.50 < m ≤ 3.55 —— 12.02	4.50 < m ≤ 4.55 —— 19.74	
2.55 < m ≤ 2.60 —— 6.45	3.55 < m ≤ 3.60 —— 12.36	4.55 < m ≤ 4.60 —— 20.18	
2.60 < m ≤ 2.65 —— 6.70	3.60 < m ≤ 3.65 —— 12.71	4.60 < m ≤ 4.65 —— 20.62	
2.65 < m ≤ 2.70 —— 6.96	3.65 < m ≤ 3.70 —— 13.06	4.65 < m ≤ 4.70 —— 21.07	
2.70 < m ≤ 2.75 —— 7.22	3.70 < m ≤ 3.75 —— 13.41	4.70 < m ≤ 4.75 —— 21.52	
2.75 < m ≤ 2.80 —— 7.48	3.75 < m ≤ 3.80 —— 13.77	4.75 < m ≤ 4.80 —— 21.97	
2.80 < m ≤ 2.85 —— 7.75	3.80 < m ≤ 3.85 —— 14.14	4.80 < m ≤ 4.85 —— 22.43	
2.85 < m ≤ 2.90 —— 8.02	3.85 < m ≤ 3.90 —— 14.51	4.85 < m ≤ 4.90 —— 22.90	

Ceiling mounted (2.2m)			
m(kg)——Amin(m ²)	m(kg)——Amin(m ²)	m(kg)——Amin(m ²)	m(kg)——Amin(m ²)
m ≤ 1.22 —— 4.00	3.05 < m ≤ 3.10 —— 6.14	3.70 < m ≤ 3.75 —— 8.98	4.35 < m ≤ 4.40 —— 12.36
1.22 < m ≤ 2.50 —— 4.00	3.10 < m ≤ 3.15 —— 6.34	3.75 < m ≤ 3.80 —— 9.22	4.40 < m ≤ 4.45 —— 12.64
2.50 < m ≤ 2.55 —— 4.16	3.15 < m ≤ 3.20 —— 6.54	3.80 < m ≤ 3.85 —— 9.47	4.45 < m ≤ 4.50 —— 12.93
2.55 < m ≤ 2.60 —— 4.32	3.20 < m ≤ 3.25 —— 6.75	3.85 < m ≤ 3.90 —— 9.71	4.50 < m ≤ 4.55 —— 13.22
2.60 < m ≤ 2.65 —— 4.49	3.25 < m ≤ 3.30 —— 6.96	3.90 < m ≤ 3.95 —— 9.96	4.55 < m ≤ 4.60 —— 13.51
2.65 < m ≤ 2.70 —— 4.66	3.30 < m ≤ 3.35 —— 7.17	3.95 < m ≤ 4.00 —— 10.22	4.60 < m ≤ 4.65 —— 13.80
2.70 < m ≤ 2.75 —— 4.83	3.35 < m ≤ 3.40 —— 7.38	4.00 < m ≤ 4.05 —— 10.47	4.65 < m ≤ 4.70 —— 14.10
2.75 < m ≤ 2.80 —— 5.01	3.40 < m ≤ 3.45 —— 7.60	4.05 < m ≤ 4.10 —— 10.73	4.70 < m ≤ 4.75 —— 14.40
2.80 < m ≤ 2.85 —— 5.19	3.45 < m ≤ 3.50 —— 7.82	4.10 < m ≤ 4.15 —— 11.00	4.75 < m ≤ 4.80 —— 14.71
2.85 < m ≤ 2.90 —— 5.37	3.50 < m ≤ 3.55 —— 8.05	4.15 < m ≤ 4.20 —— 11.26	4.80 < m ≤ 4.85 —— 15.02
2.90 < m ≤ 2.95 —— 5.56	3.55 < m ≤ 3.60 —— 8.28	4.20 < m ≤ 4.25 —— 11.53	4.85 < m ≤ 4.90 —— 15.33
2.95 < m ≤ 3.00 —— 5.75	3.60 < m ≤ 3.65 —— 8.51	4.25 < m ≤ 4.30 —— 11.81	4.90 < m ≤ 4.95 —— 15.64
3.00 < m ≤ 3.05 —— 5.94	3.65 < m ≤ 3.70 —— 8.74	4.30 < m ≤ 4.35 —— 12.08	4.95 < m ≤ 5.00 —— 15.96

m: The amount of refrigerant represented by “m” in the table is the sum of the nameplate nominal charge and the additional amount of refrigerant mentioned in the instruction manual NOTE ON ADDING REFRIGERANT.

A_{min}: Minimum floor area

Maximum refrigerant charge amount:

Maximum refrigerant charge amount			
MODEL		KAM4HR-80 DR8	KAM3HR-52 DR8
Maximum refrigerant charge amount	kg	2.8	2.3
	oz	98.8	81.1

⚠️ DISPOSAL AND RECYCLING

Important instructions for environment (European Disposal Guidelines)

Compliance with the WEEE Directive and Disposing of the Waster Product: This product complies with EU WEEE Directive. This product bears a classification symbol for waster electrical and electronic equipment (WEEE).

This symbol indicates that this product shall not be disposed with other household wastes at the end of its service life. Used device must be returned to official collection point for recycling of electrical electronic devices. To find these collection systems please contact to your local authorities or retailer where the product was purchased. Each household performs important role in recovering and recycling of old appliance. Appropriate disposal of used appliance helps prevent potential negative consequences for the environment and human health.



SPECIFICATIONS

NOTE: For multi-split type air conditioners, one outdoor unit can be matched to different types of indoor units. All of the pictures in this manual are for demonstration purposes only. Your air conditioner may be different in shape. The following pages introduce several kinds of indoor units that can be matched with the outdoor units.

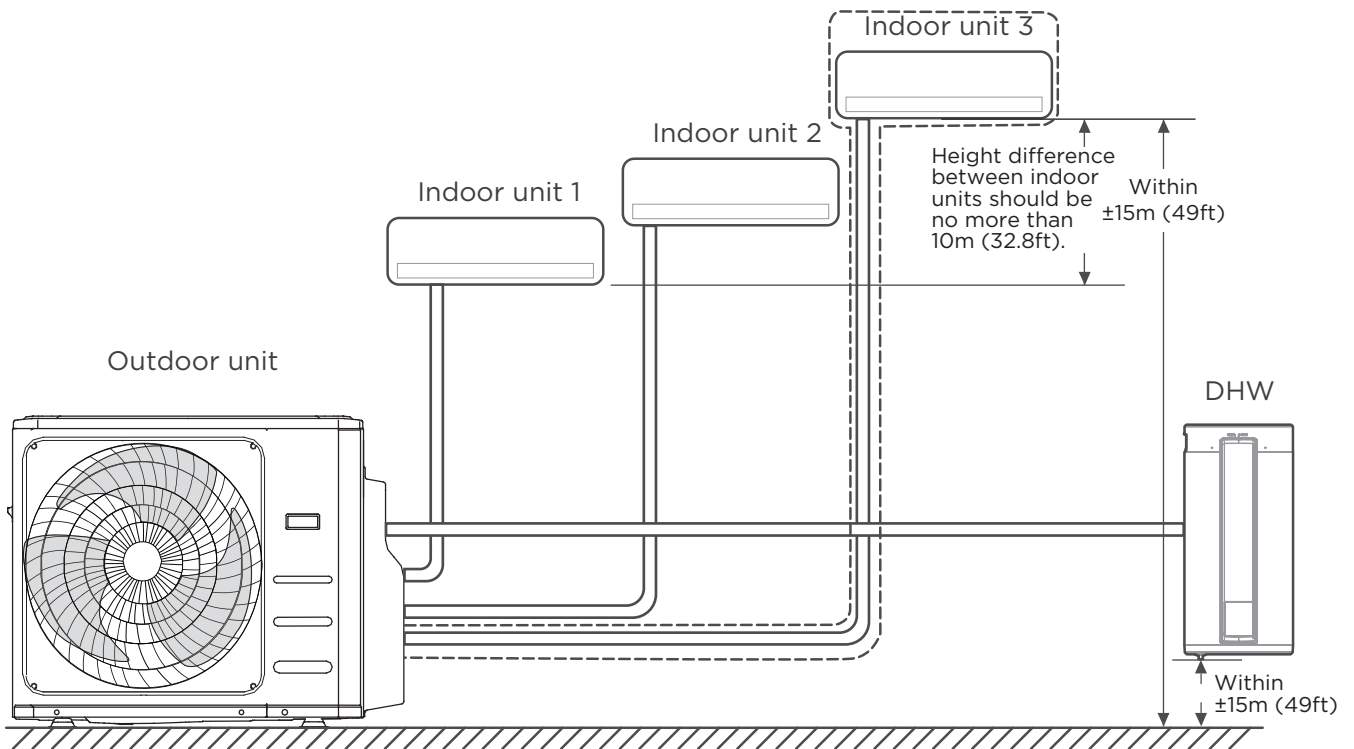
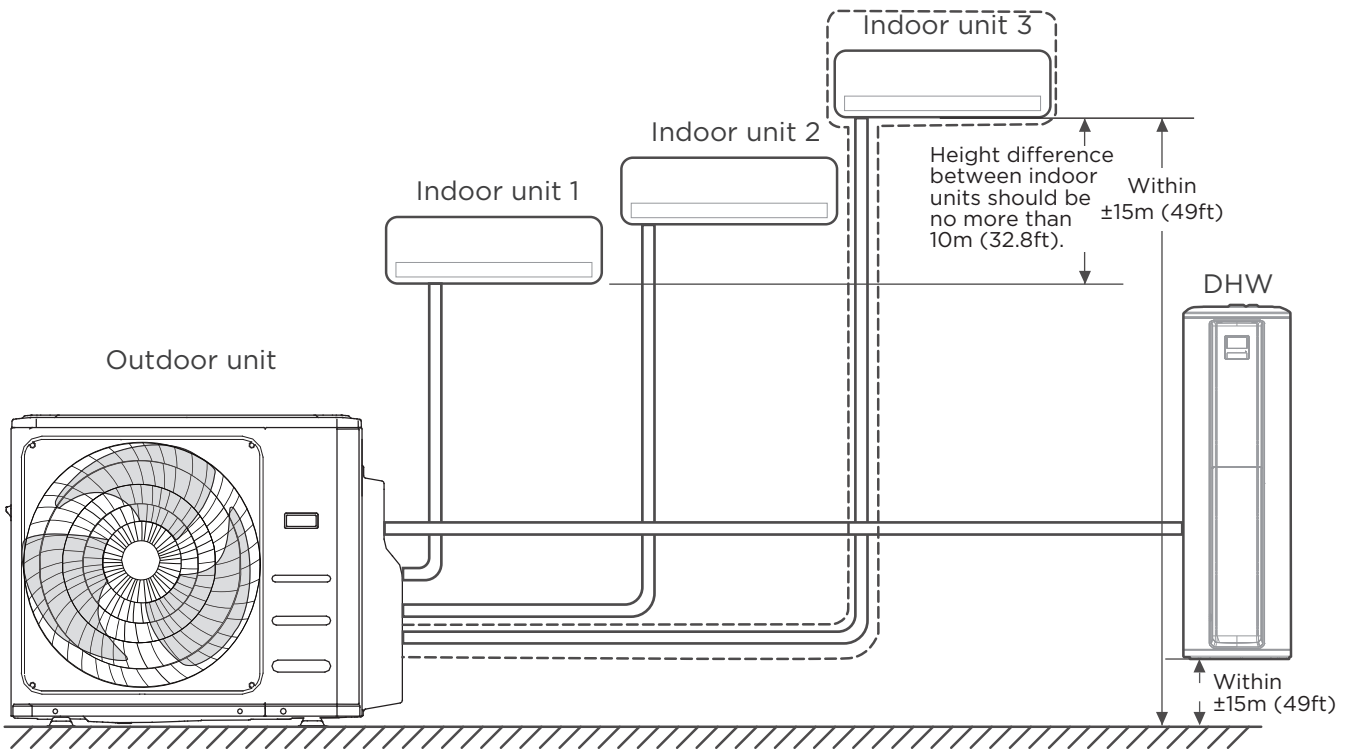

When installing multiple indoor units with a single outdoor unit, ensure that the length of the refrigerant pipe and the drop height between the indoor and outdoor units meet the requirements illustrated in the next page diagram:

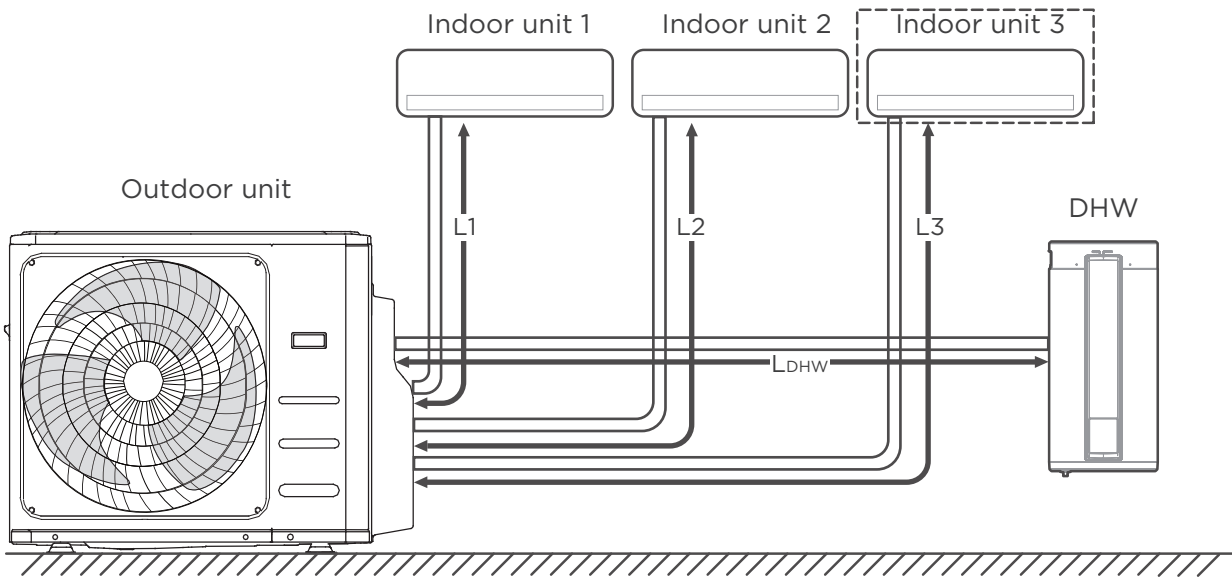
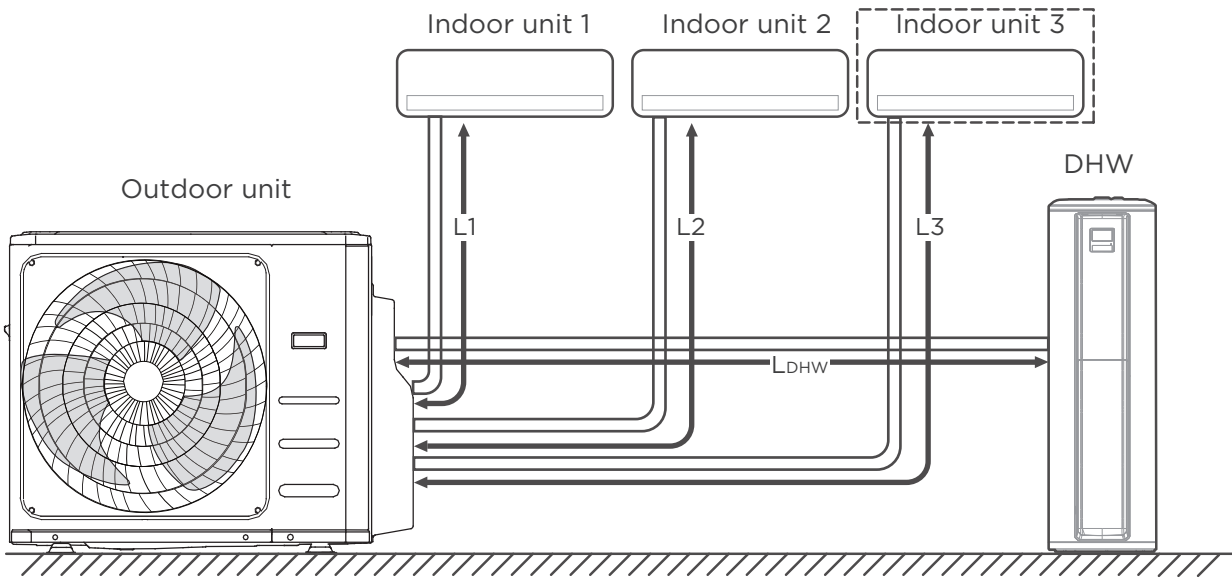

Piping length

L1/L2/L3/L_{DHW}: Piping length is the one-way length of liquid piping.

ONE-FOUR: $L1+L2+L3+L_{DHW}=\text{Maximum } 80\text{m}$

ONE-THREE: $L1+L2+L_{DHW}=\text{Maximum } 60\text{m}$

Minimum piping length for each indoor unit is 3m (5m for DHW).

Maximum piping length for each indoor unit is 35m (20m for DHW).

⚠ CAUTION

- The product can be used with one DHW.
- The product can be used with an Air Conditioner unit.
- The product can be used with both a DHW and an Air Conditioner.

NOTE: See the technical manual or ask your local service provider for details of the specific internal machine combinations.

Installation Diagram

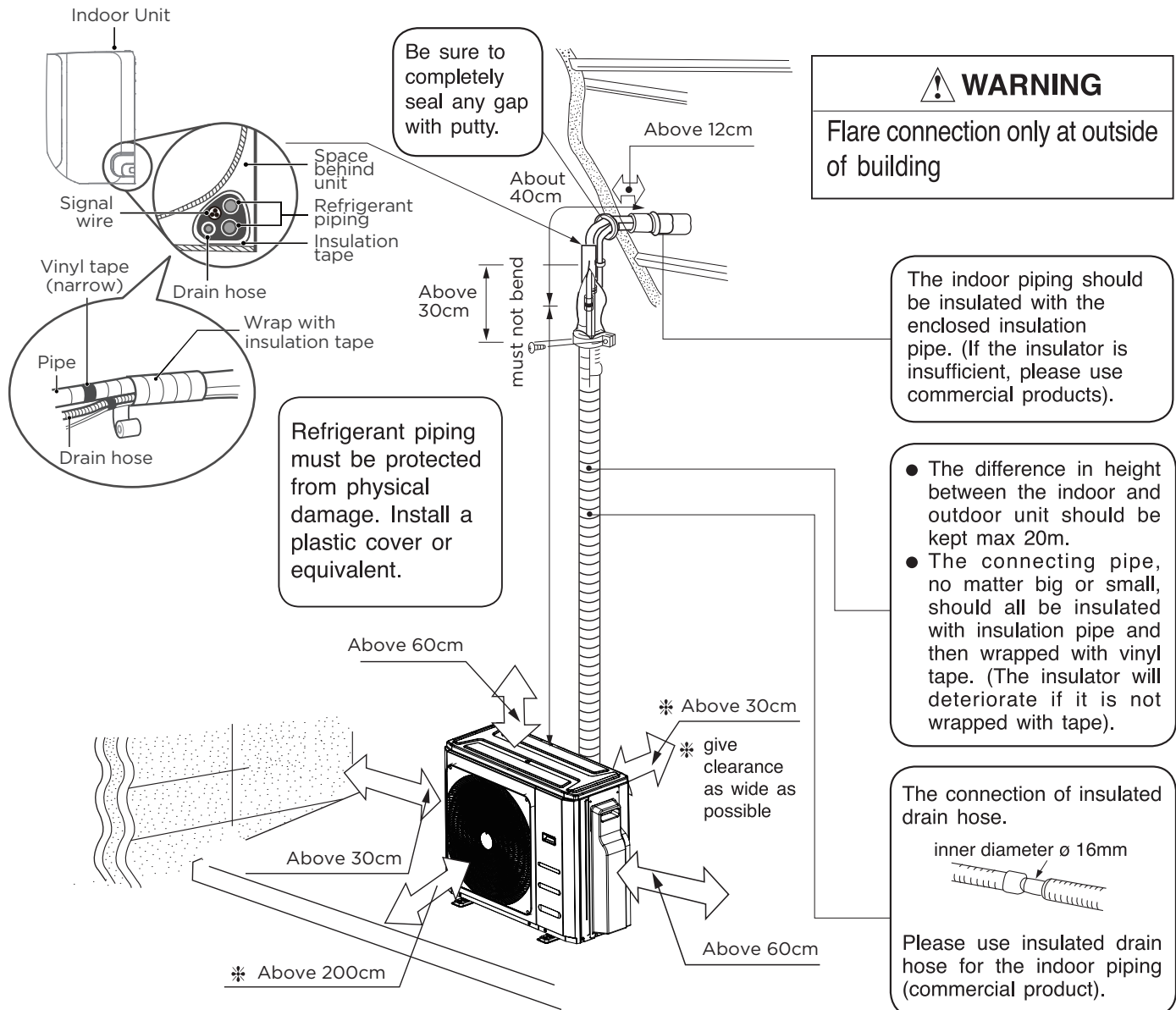

NOTE: The installation must be performed in accordance with the requirement of local and national standards. The installation may be slightly different in different areas.



⚠ CAUTION

- To prevent wall damage, use a stud finder to locate studs.
- A minimum pipe run of 3 meters is required to minimize vibration & excessive noise.
- This illustration is for demonstration purposes only.
- The actual shape of your air conditioner may be slightly different.
- Copper lines must be independently insulated.

PRODUCTION INSTALLATION

ACCESSORIES

The air conditioning system comes with the following accessories. Use all of the installation parts and accessories to install the air conditioner. Improper installation may result in water leakage, electrical shock and fire, or cause the equipment to fail. The items are not included with the air conditioner must be purchased separately.

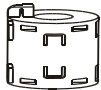
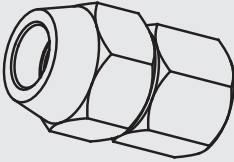
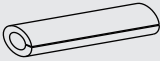
Name of Accessories	Q'ty (pc)	Shape	Name of Accessories	Q'ty (pc)	Shape
Manual	1~4		Drain joint (some models)	1	
Installation plate (some models)	1		Seal ring (some models)	1	
Plastic expansion sheath (some models)	5-8 (depending on models)		Magnetic ring (Hitch it on the connective cable between indoor unit and outdoor unit after installation.) (some models)	Varies by model	
Self-Tapping Screw A (some models)	5-8 (depending on models)				
Transfer connector (packed with the indoor or outdoor unit, depending on models) NOTE: Pipe size may differ from appliance to appliance. To meet different pipe size requirements, sometimes the pipe connections need a transfer connector installed on the outdoor unit .	Optional part (one piece/ one indoor unit) Optional part (1-5 pieces for outdoor unit, depending on models)		Cord protection rubber ring (If the cord clamp cannot fasten on a small cord, use the cord protection rubber ring [supplied with accessories] to wrap around the cord. Then fix it in place with the cord clamp.) (some models)	1	

Optional accessories

There are two types of remote controls: wired and wireless.

Select a remote controller based on customer preferences and requirements and install in an appropriate place.

Refer to catalogues and technical literature for guidance on selecting a suitable remote controller.

Name	Pipe Specification		Remark
Connecting pipe assembly	Liquid side	Ø 6.35mm (1/4in)	Parts you must purchase separately. Consult the dealer about the proper pipe size of the unit you purchased.
		Ø 9.52mm (3/8in)	
	Gas side	Ø 9.52mm (3/8in)	
		Ø 12.7mm (1/2in)	
		Ø 16mm (5/8in)	

Installation summary

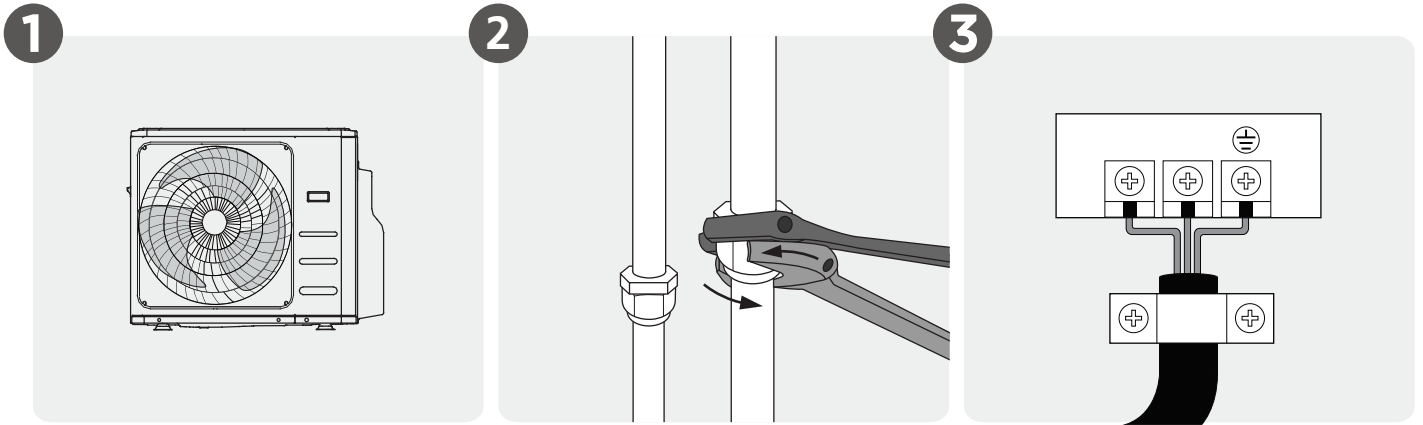

1 Install the outdoor unit

2 Connect the refrigerant pipes

3 Connect the wires

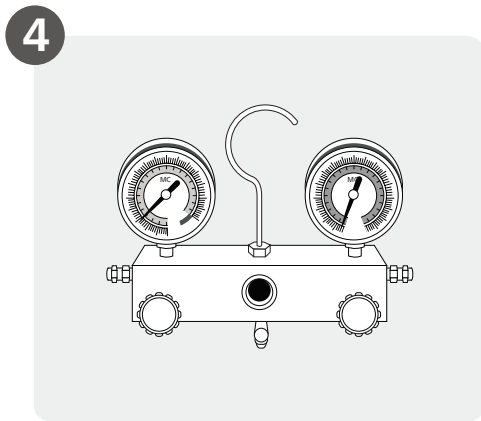

4 Evacuate the refrigeration system

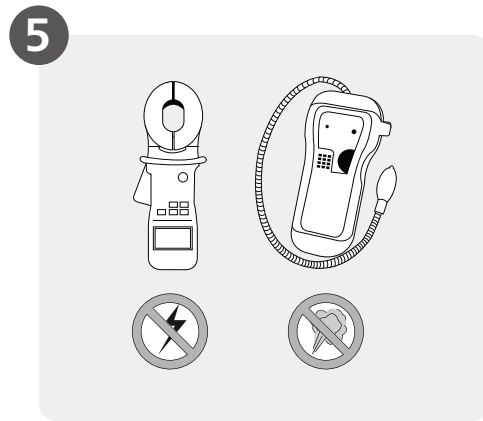

5 Perform a test run

Install Your Outdoor Unit

1 Select installation location

⚠ WARNING

Installation shall be done by an installer, the choice of materials and installation shall comply with the applicable legislation. In Europe, EN378 is the applicable standard.

NOTE: PRIOR TO INSTALLATION

Before installing the outdoor unit, you must choose an appropriate location. The following are standards that will help you choose an appropriate location for the unit.

Proper installation locations meet the following standards:

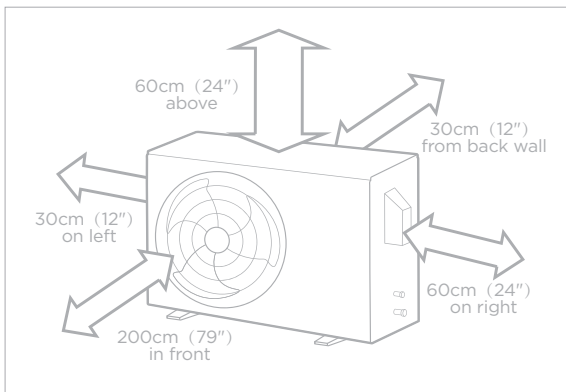

Good air circulation and ventilation.



Firm and solid—the location can support the unit and will not vibrate.



Noise from the unit will not disturb other people.



Protected from prolonged periods of direct sunlight or rain.



Where snowfall is anticipated, take appropriate measures to prevent ice buildup and coil damage.

Meets all spatial requirements shown in Installation Space Requirements above.

NOTE Install the unit by following local codes and regulations, there may be differ slightly between different regions.

The outdoor unit is designed for outdoor installation only, and for ambient temperatures within the following ranges (unless otherwise specified in the operation manual of the connected indoor unit):

DX operation range	
Cooling mode	Heating mode
-15-50°C	-15-24°C
DHW operation range	
-15-43°C	

⚠ CAUTION:

SPECIAL CONSIDERATIONS FOR EXTREME WEATHER

If the unit is exposed to heavy wind:

Install unit so that air outlet fan is at a 90° angle to the direction of the wind. If needed, build a barrier in front of the unit to protect it from extremely heavy winds. See Figures below.

If the unit is frequently exposed to heavy rain or snow:

Build a shelter above the unit to protect it from the rain or snow. Be careful not to obstruct air flow around the unit.

If the unit is frequently exposed to salty air (seaside):

Use outdoor unit that is specially designed to resist corrosion.

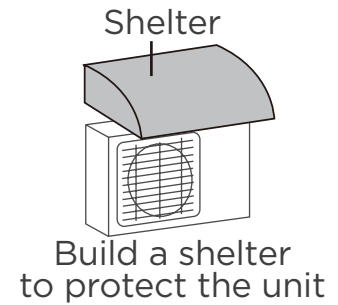
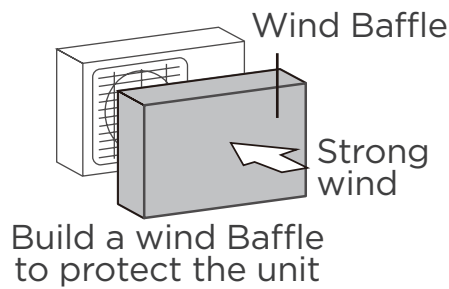
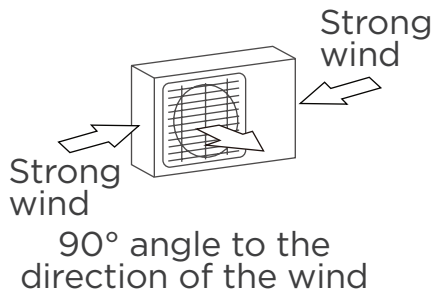

DO NOT install unit in the following locations:

- ⊘ Near an obstacle that will block air inlets and outlets.
- ⊘ Near animals or plants that will be harmed by hot air discharge.
- ⊘ In a location that is exposed to large amounts of dust
- ⊘ Near a public street, crowded areas, or where noise from the unit will disturb others.
- ⊘ Near any source of combustible gas.
- ⊘ In a location exposed to an excessive amounts of salty air.

3 Anchor Outdoor Unit

⚠ WARNING

WHEN DRILLING INTO CONCRETE, EYE PROTECTION IS RECOMMENDED AT ALL TIME.

- The outdoor unit can be anchored to the ground or to a wall-mounted bracket with bolt (M10). Prepare the installation base of the unit according to the dimensions below.
- The following is a list of different outdoor unit sizes and the distance between their mounting feet. Prepare the installation base of the unit according to the dimensions below.

Outdoor Unit Types and Specifications (Split Type Outdoor Unit)

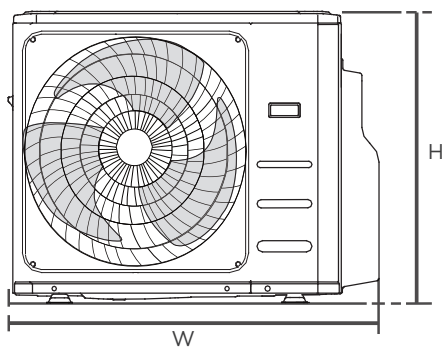

Front view

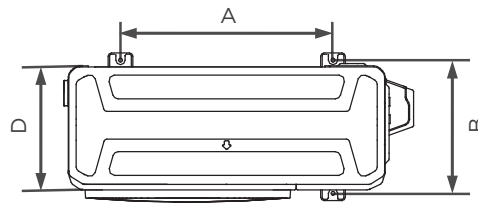

Top view

(unit: mm/inch)

Outdoor Unit Dimensions	W x H x D	Mounting Dimensions	
		Distance A	Distance B
946x810x410	(37.2x31.9x16.14)	673 (26.5)	403 (15.87)
890x673x342	(35.0x26.5x13.5)	663 (26.1)	354 (13.9)

Rows of series installation

The relations between H, A and L are as follows.

	L	A
L ≤ H	$L \leq 1/2H$	25 cm / 9.8" or more
	$1/2H < L \leq H$	30 cm / 11.8" or more
L > H	Cannot be installed	

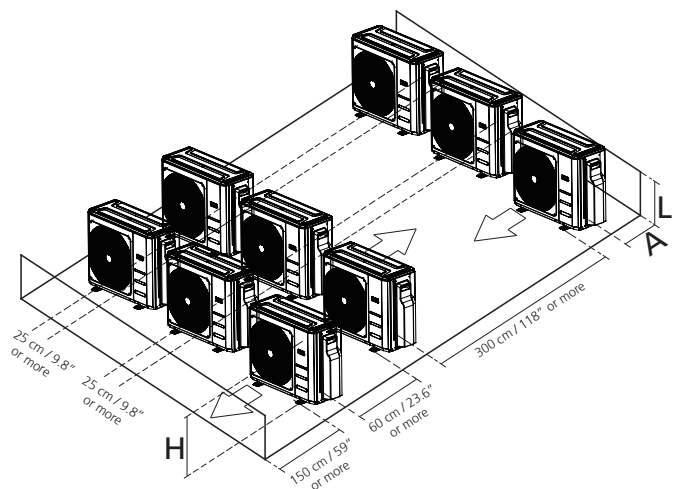

Notes On Drilling Hole In Wall

You must drill a hole in the wall for the refrigerant piping, and the signal cable that will connect the indoor and outdoor units.

1. Determine the location of the wall hole based on the location of the outdoor unit.
2. Using a 65-mm (2.5") core drill, drill a hole in the wall.

NOTE: When drilling the wall hole, make sure to avoid wires, plumbing, and other sensitive components.

3. Place the protective wall cuff in the hole. This protects the edges of the hole and helps seal it when you finish the installation process.

(unit: inch)

Indoor Unit capacity (Btu/h)	Liquid	Gas
7K/9K/12K	1/4	3/8
18K	1/4	1/2
24K	3/8	5/8

Outdoor unit pipe connection port

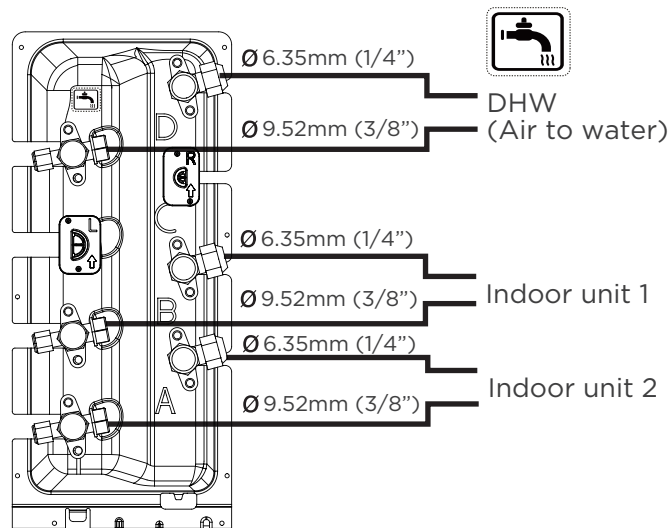

⚠ CAUTION:

- The pipe connection ports of the outdoor unit and connectable indoor units are shown above.
- The 18K indoor unit can only be connected with an A system.

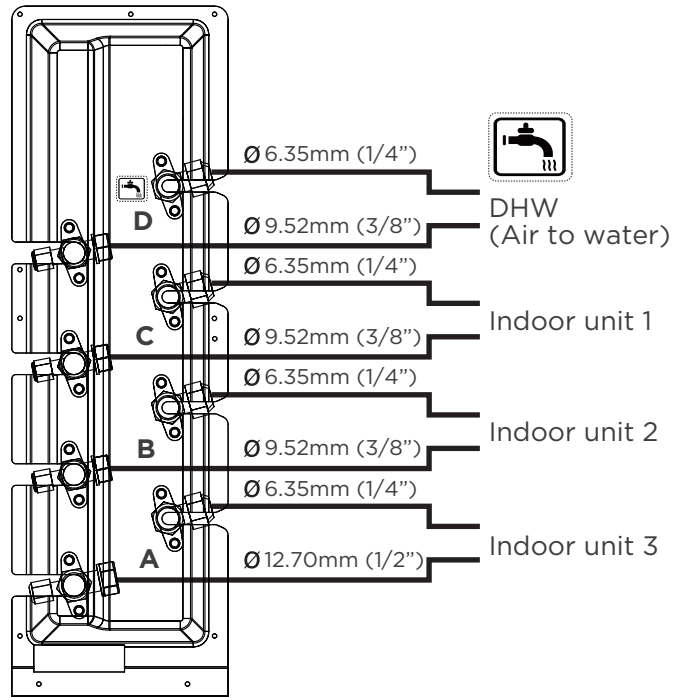

⚠ CAUTION:

- The pipe connection ports of the outdoor unit and connectable indoor units are shown above.
- The 24K indoor unit can only be connected with an A system.

2

Install drain joint (Heat pump unit only)

NOTE: PRIOR TO INSTALLATION

Before bolting the outdoor unit in place, you must install the drain joint at the bottom of the unit. For the units with base pan built-in with multiple holes for proper draining during defrost, the drain joint is no need to be installed.

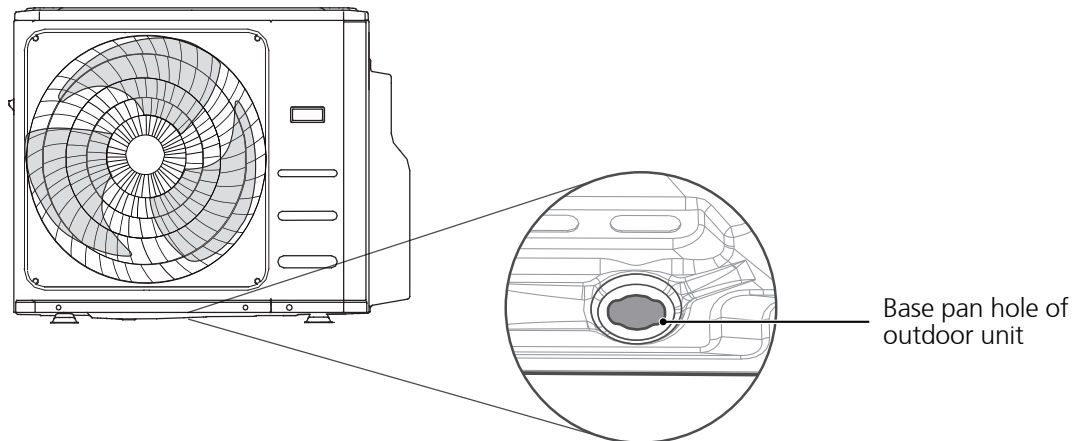

Step 1:

Find out the base pan hole of outdoor unit.



Step 2:

- Fit the rubber seal on the end of the drain joint that will connect to the outdoor unit.
- Insert the drain joint into the hole in the base pan of the unit. The drain joint will click in place.
- Connect a drain hose extension (not included) to the drain joint to redirect water from the unit during heating mode.

IN COLD CLIMATES

In cold climates, make sure that the drain hose is as vertical as possible to ensure swift water drainage. If water drains too slowly, it can freeze in the hose and flood the unit.

REFRIGERANT PIPING CONNECTION

When connecting refrigerant piping, **DO NOT** let substances or gases other than the specified refrigerant enter the unit. The presence of other gases or substances will lower the unit's capacity, and can cause abnormally high pressure in the refrigeration cycle. This can cause explosion and injury.

Refrigerant piping insulation

- Use polyethylene foam as insulation material:
 - with a heat transfer rate between 0.041 and 0.052 W/mK (0.035 and 0.045 kcal/mh°C)
 - with a heat resistance of at least 120°C
- Insulation thickness

Pipe outer diameter (\varnothing_p)	Insulation inner diameter (\varnothing_i)	Insulation thickness (t)
6.35 mm (1/4")	8-10 mm	≥ 10 mm
9.52 mm (3/8")	12-15 mm	≥ 13 mm
12.7 mm (1/2")	14-16 mm	≥ 13 mm

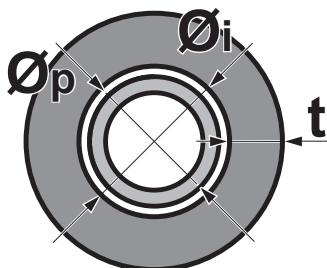

If the temperature is higher than 30°C and the humidity is higher than RH 80%, the thickness of the insulation materials should be at least 20 mm to prevent condensation on the surface of the insulation.

Use separate thermal insulation pipes for the gas and liquid refrigerant piping.

Connection Instructions—Refrigerant Piping

CAUTION

- The branching pipe must be installed horizontally. An angle of more than 10° may cause malfunction.
- **DO NOT** install the connecting pipe until both indoor and outdoor units have been installed.
- Insulate both the gas and liquid piping to prevent condensation.

Step 1: Cut pipes

When preparing refrigerant pipes, take extra care to cut and flare them properly. This will ensure efficient operation and minimize the need for future maintenance.

- Measure the distance between the indoor and outdoor units.
- Using a pipe cutter, cut the pipe a little longer than the measured distance.
- Make sure that the pipe is cut at a perfect 90° angle.

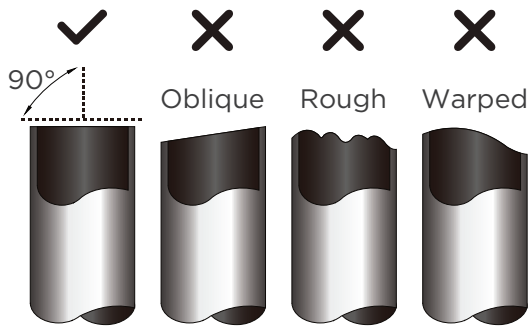

DO NOT DEFORM PIPE WHILE CUTTING

Be extra careful not to damage, dent, or deform the pipe while cutting. This will drastically reduce the heating

Step 2: Remove burrs

Burrs can affect the air-tight seal of refrigerant piping connection. They must be completely removed.

- Hold the pipe at a downward angle to prevent burrs from falling into the pipe.
- Using a reamer or deburring tool, remove all burrs from the cut section of the pipe.

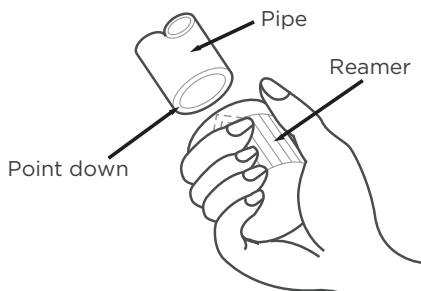

Step 3: Flare pipe ends

Proper flaring is essential to achieve an airtight seal.

- After removing burrs from cut pipe, seal the ends with PVC tape to prevent foreign materials from entering the pipe.
- Sheath the pipe with insulating material.
- Place flare nuts on both ends of pipe. Make sure they are facing in the right direction, because you can't put them on or change their direction after flaring.

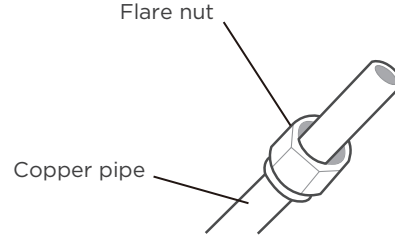

- Remove PVC tape from ends of pipe when ready to perform flaring work.
- Clamp flare form on the end of the pipe. The end of the pipe must extend beyond the flare form.

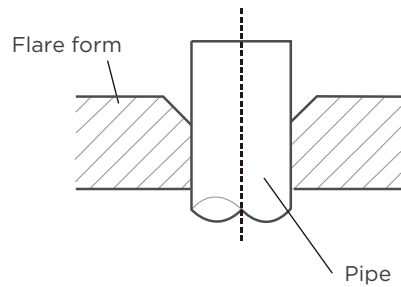

- Place flaring tool onto the form.
- Turn the handle of the flaring tool clockwise until the pipe is fully flared.

PIPING EXTENSION BEYOND FLARE FORM

Pipe gauge	Tightening torque	Flare dimension (A) (Unit: mm/Inch)		Flare shape
		Min.	Max.	
Ø 6.35 (Ø 1/4")	18-20 N.m (180-200kgf.cm)	8.4/0.33	8.7/0.34	
Ø 9.52 (Ø 3/8")	32-39 N.m (320-390kgf.cm)	13.2/0.52	13.5/0.53	
Ø 12.7 (Ø 1/2")	49-59 N.m (490-590kgf.cm)	16.2/0.64	16.5/0.65	
Ø 16 (Ø 5/8")	57-71 N.m (570-710kgf.cm)	19.2/0.76	19.7/0.78	
Ø 19 (Ø 3/4")	67-101 N.m (670-1010kgf.cm)	23.2/0.91	23.7/0.93	
Ø 22 (Ø 7/8")	85-110 N.m (850-1100kgf.cm)	26.4/1.04	26.9/1.06	

- Remove the flaring tool and flare form, then inspect the end of the pipe for cracks and even flaring.

Step 4: Connect pipes

Connect the copper pipes to the indoor unit first, then connect it to the outdoor unit. You should first connect the low-pressure pipe, then the high pressure pipe.

- When connecting the flare nuts, apply a thin coat of refrigeration oil to the flared ends of the pipes.
- Align the center of the two pipes that you will connect.

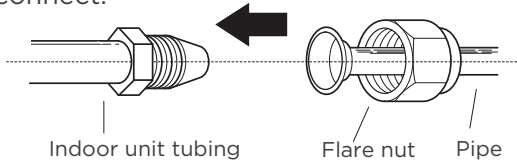

- Tighten the flare nut snugly by hand.
- Using a wrench, grip the nut on the unit tubing.
- While firmly gripping the nut, use a torque wrench to tighten the flare nut according to the torque values in above table.

NOTICE

Use both a spanner and a torque wrench when connecting or disconnecting pipes to/from the unit.

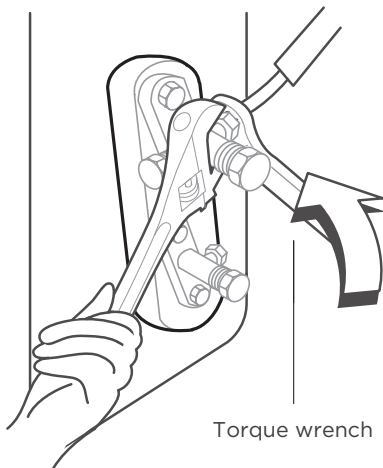

CAUTION

Ensure to wrap insulation around the piping. Direct contact with the bare piping may result in burns or frostbite.

- Make sure the pipe is properly connected. Over tightening may damage the bell mouth and under tightening may lead to leakage.

NOTICE

MINIMUM BEND RADIUS

Carefully bend the tubing in the middle according to the diagram below.

DO NOT bend the tubing more than 90° or more than 3 times.

Use appropriate tool

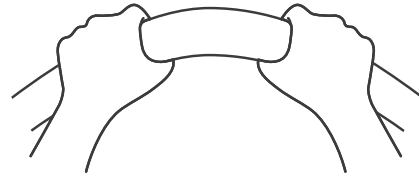

min-radius 10cm (3.9")

- After connecting the copper pipes to the indoor unit, wrap the power cable, signal cable and the piping together with binding tape.

NOTICE

DO NOT intertwine signal cable with other wires. While bundling these items together.

DO NOT intertwine or cross the signal cable with any other wiring.

WIRING PRECAUTIONS

⚠ WARNING

BEFORE PERFORMING ANY ELECTRICAL WORK, READ THESE WARNINGS.

- All wiring must comply with local and national electrical codes, regulations and must be installed by a licensed electrician.
- All electrical connections must be made according to the Electrical Connection Diagram located on the panels of the indoor and outdoor units.
- If there is a serious safety issue with the power supply, stop work immediately. Explain your reasoning to the client, and refuse to install the unit until the safety issue is properly resolved.
- Power voltage should be within 90-110% of rated voltage. Insufficient power supply can cause malfunction, electrical shock, or fire.
- Installation of an external surge suppressor at the outdoor disconnect is recommended.
- If connecting power to fixed wiring, a switch or circuit breaker that disconnects all poles and has a contact separation of at least 1/8in (3mm) must be incorporated in the fixed wiring. The qualified technician must use an approved circuit breaker or switch.
- Only connect the unit to an individual branch circuit. Do not connect another appliance to that outlet.
- Make sure to properly ground the air conditioner.
- Every wire must be firmly connected. Loose wiring can cause the terminal to overheat, resulting in product malfunction and possible fire.
- Do not let wires touch or rest against refrigerant tubing, the compressor, or any moving parts within the unit.
- If the unit has an auxiliary electric heater, it must be installed at least 1 meter (40in) away from any combustible materials.
- To avoid getting an electric shock, never touch the electrical components soon after the power supply has been turned off. After turning off the power, always wait 10 minutes or more before you touch the electrical components.
- Make sure that you do not cross your electrical wiring with your signal wiring.
- This may cause distortion, interference or possibly damage to circuit boards.
- No other equipment should be connected to the same power circuit.
- Connect the outdoor wires before connecting the indoor wires.

⚠ WARNING

BEFORE PERFORMING ANY ELECTRICAL OR WIRING WORK, TURN OFF THE MAIN POWER TO THE SYSTEM.

NOTE ON AIR SWITCH

When the maximum current of the air conditioner is more than 16A, an air switch or leakage protection switch with protective device shall be used (purchased separately). When the maximum current of the air conditioner is less than 16A, the power cord of air conditioner shall be equipped with plug (purchased separately). In North America, the appliance should be wired according to NEC and CEC requirements.

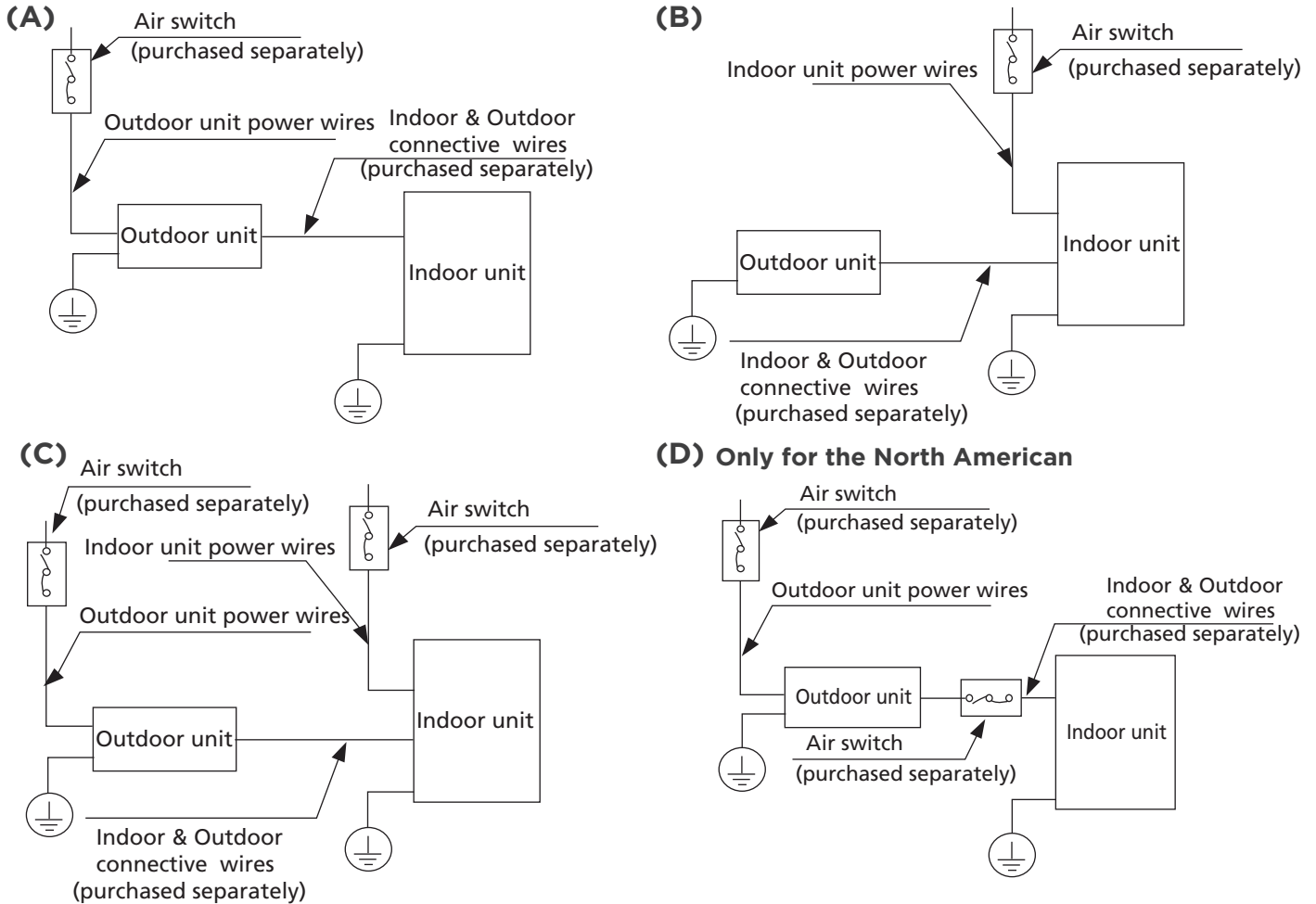

NOTE: The cographs are for explanation purpose only. Your machine may be slightly different. The actual shape shall prevail.

OUTDOOR UNIT WIRING

⚠ WARNING

Before performing any electrical or wiring work, turn off the main power to the system.

1. Prepare the cable for connection
 - a. You must first choose the right cable size. Be sure to use H07RN-F cables.

Minimum Cross-Sectional Area of Power and Signal Cables-For reference (Not applicable for North America)

Rated Current of Appliance (A)	Nominal Cross-Sectional Area (mm ²)
> 3 and ≤ 6	0.75
> 6 and ≤ 10	1
> 10 and ≤ 16	1.5
> 16 and ≤ 25	2.5
> 25 and ≤ 32	4
> 32 and ≤ 40	6

CHOOSE THE RIGHT CABLE SIZE

The size of the power supply cable, signal cable, fuse, and switch needed is determined by the maximum current of the unit. The maximum current is indicated on the nameplate located on the side panel of the unit. Refer to this nameplate to choose the right cable, fuse, or switch.

- b. Using wire strippers, strip the rubber jacket from both ends of the signal cable to reveal approximately 15cm (5.9”) of wire.
- c. Strip the insulation from the ends.
- d. Using a wire crimper, crimp u-lugs on the ends.

NOTE: When connecting the wires, strictly follow the wiring diagram found inside the electrical box cover.

- 2. Unscrew the electrical wiring cover and remove it.
- 3. Unscrew the cable clamp below the terminal block and place it to the side.
- 4. Connect the wire according to the wiring diagram, and firmly screw the u-lug of each wire to its corresponding terminal.
- 5. After checking to make sure every connection is secure, loop the wires around to prevent rain water from flowing into the terminal.
- 6. Using the cable clamp, fasten the cable to the unit. Screw the cable clamp down tightly.
- 7. Insulate unused wires with PVC electrical tape. Arrange them so that they do not touch any electrical or metal parts.
- 8. Replace the wire cover on the side of the unit, and screw it in place.

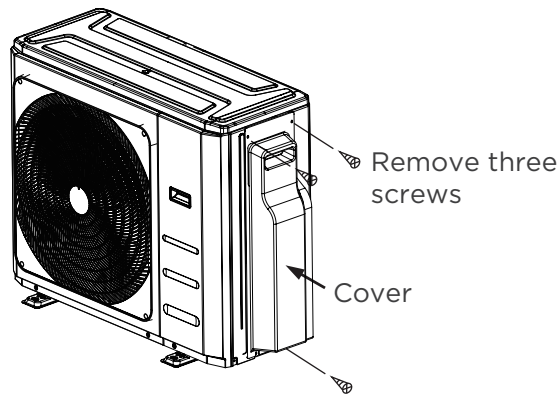

NOTE: If the cable clamp looks like the following, please select the appropriate through-hole according to the diameter of the wire.

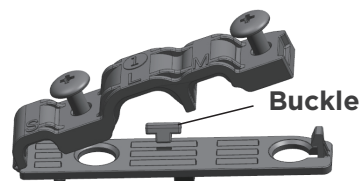

Three size holes: Small, Large, Medium

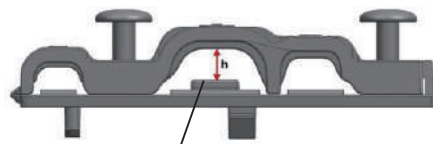

When the cable is not fastened enough, use the buckle to prop it up, so it can be clamped tightly.

Wiring Figure

⚠ CAUTION
 Connect the connective cables to the terminals, as identified, with their matching numbers on the terminal block of the indoor and outdoor units. For example, Terminal L1 (A) of the outdoor unit must connect with terminal L1/1 on the indoor unit. The outdoor unit can match different types of indoor unit, the numbers on the terminal block of the indoor unit may be slightly different. Please pay special attention while connecting the wire.

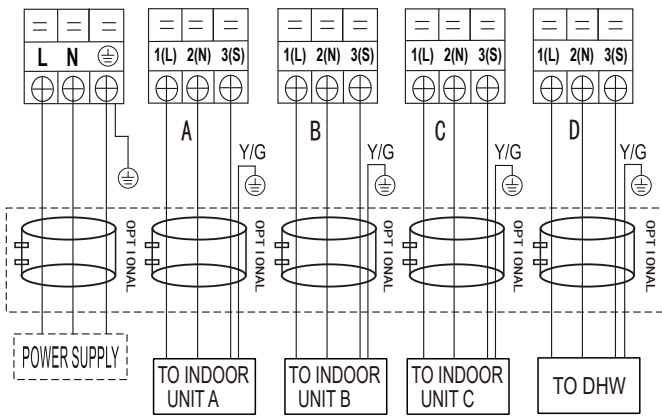

MODEL A

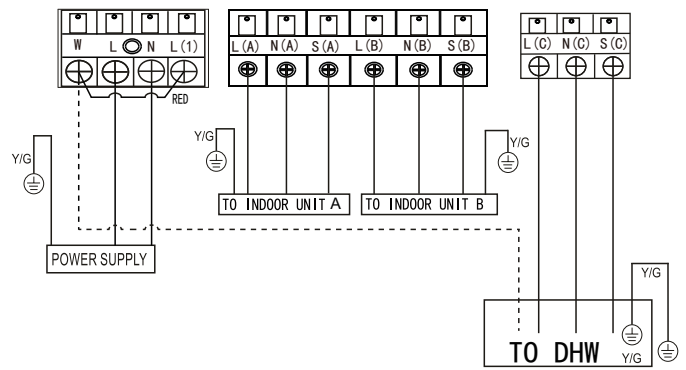

MODEL B

Notes: Please remove the red cable when the outdoor unit only connected with DHW tank, and connect the DHW water tank W wire to the outdoor unit W terminal. But reserve the red cable if there are both air conditioner and DHW tank.

How to achieve low power consumption standby function

Applicable models: Only suitable for KAM3HR-52 DR8 outdoor units, and only PBSX-100(30)/DN8-A DHW tank is connected. It is not suitable for scenarios that DHW water tank and air conditioner indoor unit are matched with KAM3HR-52 DR8 ODU at the same time. When KAM3HR-52 DR8 outdoor unit only connecting to the DHW tank, remove the red short-circuit wire in the middle of the W and L terminals of the outdoor unit, and connect the DHW water tank W wire to the outdoor unit W terminal to achieve low power consumption standby function.

NOTE:  This symbol indicates the element is optional, the actual shape shall be prevailed.

⚠ CAUTION

After confirmation of the above conditions, follow these guidelines when performing wiring:

- Always have an individual power circuit specifically for the air conditioner. Always follow the circuit diagram posted on the inside of the control cover.
- Screws fastening the wiring in the casing of electrical fittings may come loose during transportation. Because loose screws may cause wire burn-out, check that the screws are tightly fastened.
- Check the specifications for the power source.
- Confirm that electrical capacity is sufficient.
- Confirm that starting voltage is maintained at more than 90 percent of the rated voltage marked on the name plate.
- Confirm that the cable thickness is as specified in the power source specifications.
- Always install an earth leakage circuit breaker in wet or moist areas.
- The following can be caused by a drop in voltage: vibration of a magnetic switch, damaging the contact point, broken fuses, and disturbance of normal functioning.
- Disconnection from a power supply must be incorporated into the fixed wiring. It must have an air gap contact separation of at least 3mm in each active (phase) conductors.
- Before accessing terminals, all supply circuits must be disconnected.

NOTE:

To satisfy the EMC compulsory regulations, which is required by the international standard CISPR 14-1:2005/A2:2011 in specific countries or districts, please make sure you apply the correct magnetic rings on your equipment according to the wiring diagram that adhere to your equipment. Please contact your distributor or installer to get further information and purchase magnetic rings (The supplier of magnetic ring is TDK (model ZCAT3035-1330) or similar).

AIR EVACUATION

NOTICE

When opening valve stems, turn the hexagonal wrench until it hits against the stopper. Do not try to force the valve to open further.

Preparations and precautions

Air and foreign matter in the refrigerant circuit can cause abnormal rises in pressure, which can damage the air conditioner, reduce its efficiency, and cause injury. Use a vacuum pump and manifold gauge to evacuate the refrigerant circuit, removing any non-condensable gas and moisture from the system. Evacuation should be performed upon initial installation and when unit is relocated.

BEFORE PERFORMING EVACUATION

- ✓ Check to make sure the connective pipes between the indoor and outdoor units are connected properly.
- ✓ Check to make sure all wiring is connected properly.

Evacuation Instructions

1. Connect the charge hose of the manifold gauge to service port on the outdoor unit's low pressure valve.
2. Connect another charge hose from the manifold gauge to the vacuum pump.
3. Open the Low Pressure side of the manifold gauge. Keep the High Pressure side closed.
4. Turn on the vacuum pump to evacuate the system.
5. Run the vacuum for at least 15 minutes and the Compound Meter reads -76cmHg (-10^5Pa).

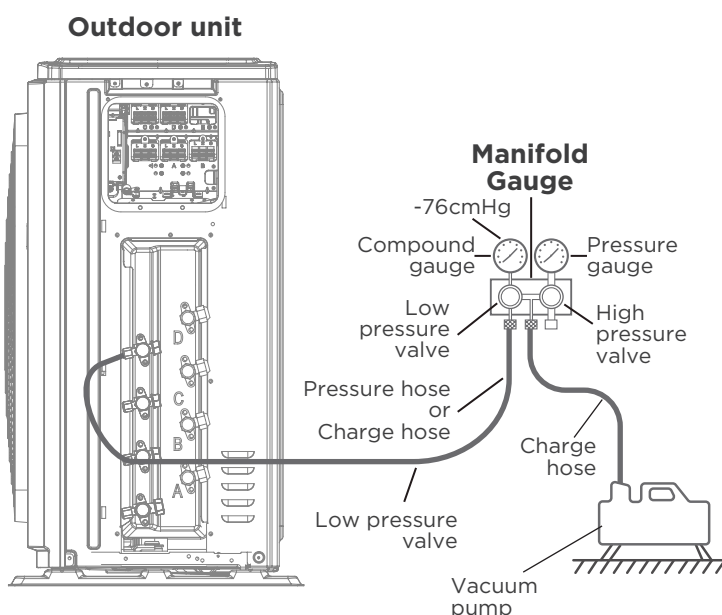

6. Close the Low Pressure side of the manifold gauge, and turn off the vacuum pump.
7. Wait for 5 minutes, then check that there has been no change in system pressure.
8. If there is a change in system pressure, refer to Gas Leak Check section for information on how to check for leaks. If there is no change in system pressure, unscrew the cap from the packed valve (high pressure valve).
9. Insert hexagonal wrench into the packed valve (high pressure valve) and open the valve by turning the wrench in a 1/4 counterclockwise turn. Listen for gas to exit the system, then close the valve after 5 seconds.
10. Watch the Pressure Gauge for one minute to make sure that there is no change in pressure. The Pressure Gauge should read slightly higher than atmospheric pressure.
11. Remove the charge hose from the service port.

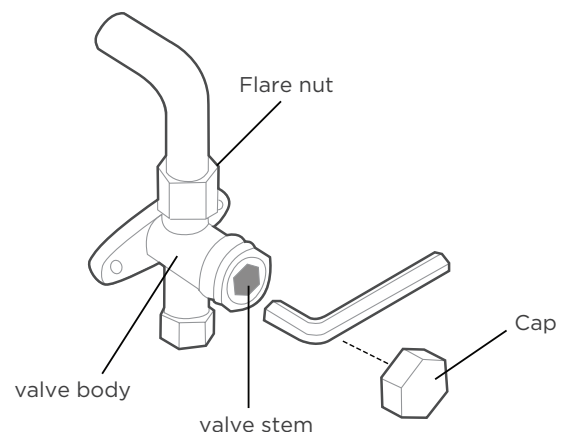

12. Using hexagonal wrench, fully open both the high pressure and low pressure valves.
13. Tighten valve caps on all three valves (service port, high pressure, low pressure) by hand. You may tighten it further using a torque wrench if needed.
14. Follow the above steps one system at a time.

NOTE ON ADDING REFRIGERANT

⚠ CAUTION

- Refrigerant charging must be performed after wiring, vacuuming, and the leak testing.
- **DO NOT** exceed the maximum allowable quantity of refrigerant or overcharge the system. Doing so can damage the unit or impact its functioning.
- Charging with unsuitable substances may cause explosions or accidents. Ensure that the appropriate refrigerant is used.
- Refrigerant containers must be opened slowly. Always use protective gear when charging the system.
- **DO NOT** mix refrigerants types.
- For the R32 refrigerant model, make sure the conditions within the area have been made safe by control of flammable material when the refrigerant added into air conditioner.

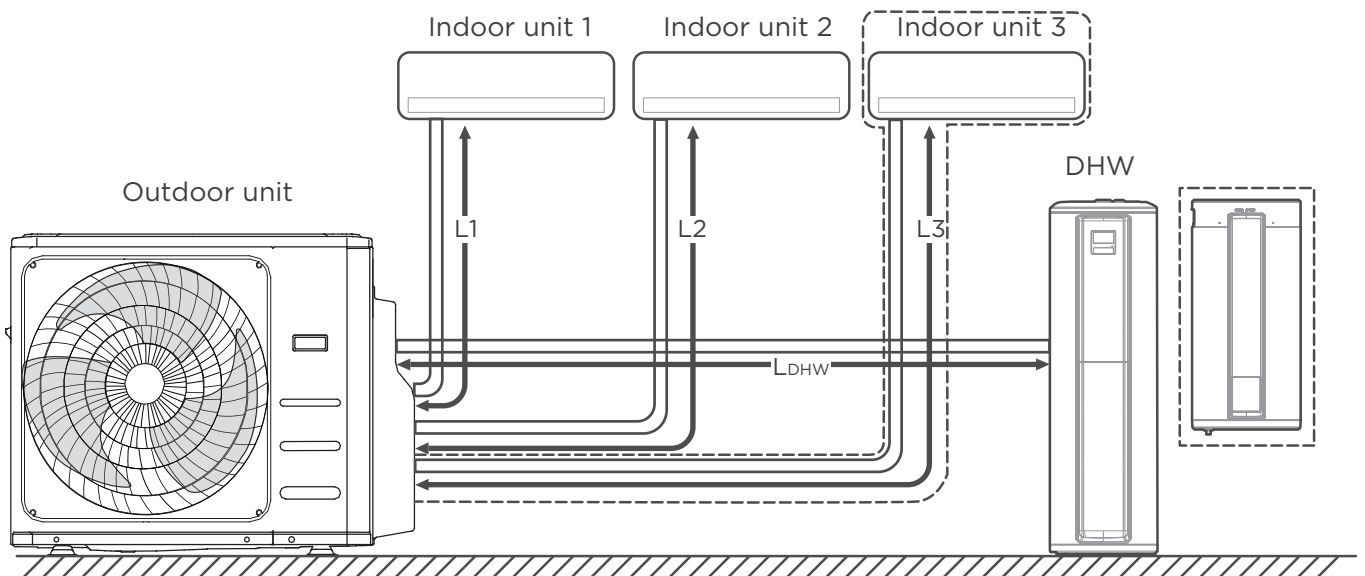

Refrigerant charge

MODEL		KAM4HR-80 DR8	KAM3HR-52 DR8
Standard pipe length (L1+L2+.....+LDHW)	m	30	20
	ft	98.4	65.6
Additional refrigerant charge	kg	$0.02 \times ((L1+L2+L3+L_{DHW})-30)$	$0.02 \times ((L1+L2+L_{DHW})-20)$
	oz	$0.215 \times ((L1+L2+L3+L_{DHW})-98.4)$	$0.215 \times ((L1+L2+L_{DHW})-65.6)$

Safety And Leakage Check

Electrical safety check

Perform the electrical safety check after completing installation. Cover the following areas:

1. Insulated resistance
The insulated resistance must be more than 2MΩ.
2. Grounding work
After finishing grounding work, measure the grounding resistance by visual detection and using the grounding resistance tester. Make sure the grounding resistance is less than 4Ω.
3. Electrical leakage check (performing during test while unit is on)
During a test operation after completed installation, the use the electro probe and multimeter to perform an electrical leakage check. Turn off the unit immediately if leakage happens. Try and evaluate different solutions until the unit operates properly.

To charge additional refrigerant

⚠ WARNING

- Only use R32 as refrigerant. Other substances may cause explosions and accidents.
- R32 contains fluorinated greenhouse gases. Its global warming potential (GWP) value is 675. Do NOT vent these gases into the atmosphere.
- When charging refrigerant, ALWAYS use protective gloves and safety glasses.

Prerequisite: Before charging refrigerant, make sure the refrigerant piping is connected and checked (leak test and vacuum drying).

1. Connect the refrigerant cylinder to the service port.
2. Charge the additional refrigerant amount.
3. Open the gas stop valve.

To fix the fluorinated greenhouse gases label

1. Fill in the label as follows:

This product contains fluorinated greenhouse gases and its function relies on these.

① = Manufacturing Charge(Indicated on the nameplate)
 ② = Additional Charge(See the instructions in the manual)
 ①+②= Total Amount

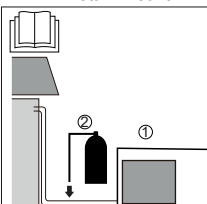

① = kg — b

② = kg — c

①+② = kg — d

$\frac{\text{GWP} \times \text{kg}}{1000} =$ tCO₂ eq — e

- a If a multilingual fluorinated greenhouse gases label is delivered with the unit (see accessories), peel off the applicable language and stick it on top of a.
- b Factory refrigerant charge: see unit name plate
- c Additional refrigerant amount charged
- d Total refrigerant charge
- e Quantity of fluorinated greenhouse gases of the total refrigerant charge expressed as tones CO₂ equivalent.
GWP = Global warming potential

NOTE: Applicable legislation on fluorinated greenhouse gases requires that the refrigerant charge of the unit is indicated both in weight and CO₂ equivalent.

Formula to calculate the quantity in CO₂ equivalent tones: GWP value of the refrigerant × total refrigerant charge [in kg] / 1000.

Use the GWP value mentioned on the refrigerant charge label.

2. Fix the label on the inside of the outdoor unit near the gas and liquid stop valves.

Gas leak check

1. Soap water method:
Apply a soap-water solution or a liquid neutral detergent on the indoor unit connection or outdoor unit connections with a soft brush to check for leakage of the connecting points of the piping. If bubbles emerge, the pipes are experiencing leakage.
2. Leak detector
Use the leak detector to check for leakage.

NOTE: The illustration is for example purposes only. The actual order of A, B, C, and D on the machine may be slightly different from the unit you purchased but the general shape will remain the same.

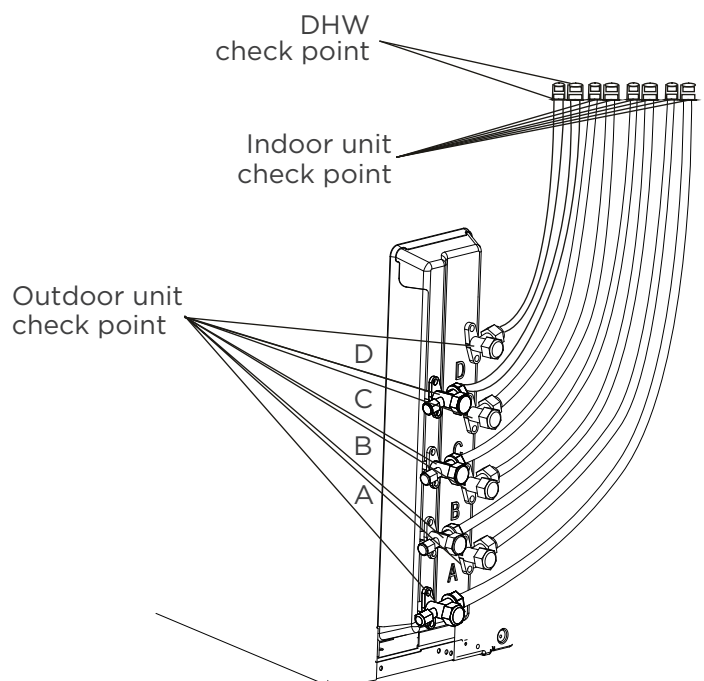

TRIAL-RUNNING

⚠ CAUTION

Failure to perform the trial-running may result in unit damage, property damage, or personal injury.

Before Trial-Running

For DHW tank test run procedure, refer to installation manual of DHW tank unit.

If the unit runs into an error during commissioning, see the service manual for the detailed troubleshooting guidelines.

A test run must be performed after the entire system has been completely installed. Confirm the following points before performing the test:

- The indoor, tank and outdoor units are properly installed.
- Refrigerant/water piping and wiring are properly connected.
- No obstacles near the inlet and outlet of the unit that might cause poor performance or product malfunction.
- The refrigeration system does not leak.
- Drainage system is unimpeded and draining to a safe location.
- The heating insulation is properly installed.
- The grounding wires are properly connected.
- Length of the piping and additional refrigerant stow capacity have been recorded.
- The power voltage is the correct voltage for the air conditioner.
- Please make sure that the tank is full of water before turning on the power as shown as below.

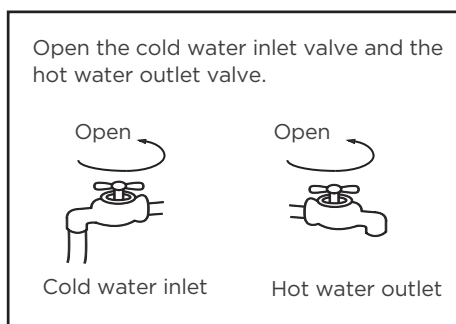

Water Affusion

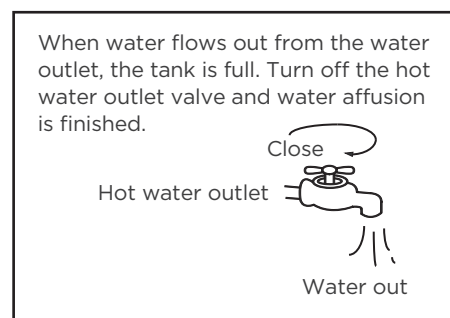

Trial-Running Instructions

- Open both the liquid and gas stop valves.
- Turn on the main power switch and allow the unit to warm up.
- Set the air conditioner to COOL mode, and set the tank to Hybrid mode
- For the Indoor Unit
 - Ensure the remote control and its buttons work properly.
 - Ensure the louvers move properly and can be changed using the remote control.
 - Double check to see if the room temperature is being registered correctly.
 - Ensure the indicators on the remote control and the display panel on the indoor unit work properly.
 - Ensure the manual buttons on the indoor unit works properly.
 - Check to see that the drainage system is unimpeded and draining smoothly.
 - Ensure there is no vibration or abnormal noise during operation.
- For the DHW
 - Condensate draining smoothly well. insulation work for all hydraulic part.
 - Correct power supply.
 - No air in the water pipeline and all valves opened.
 - Effective electric leakage protector installation.
 - Sufficient inlet water pressure (between 0.15 Mpa and 0.5 Mpa).
- For the Outdoor Unit
 - Check to see if the refrigeration system is leaking.
 - Make sure there is no vibration or abnormal noise during operation.
 - Ensure the wind, noise, and water generated by the unit do not disturb your neighbors or pose a safety hazard.

NOTE: If the unit malfunctions or does not operate according to your expectations, please refer to the Troubleshooting section of the Owner's Manual before calling customer service.

CONFIGURATION

Automatic Wiring/Piping Correction Function

⚠ CAUTION

This function is available only for the air-conditioning indoor units listed below.

More recent models now feature automatic correction of wiring/piping errors. Press the "check switch" on the outdoor unit PCB board for 5 seconds until the LED displays "CE", indicating that this function is working, approximately 5-10 minutes after the switch is pressed, the "CE" disappears, meaning that the wiring/piping error is corrected and all wiring/piping is properly connected.

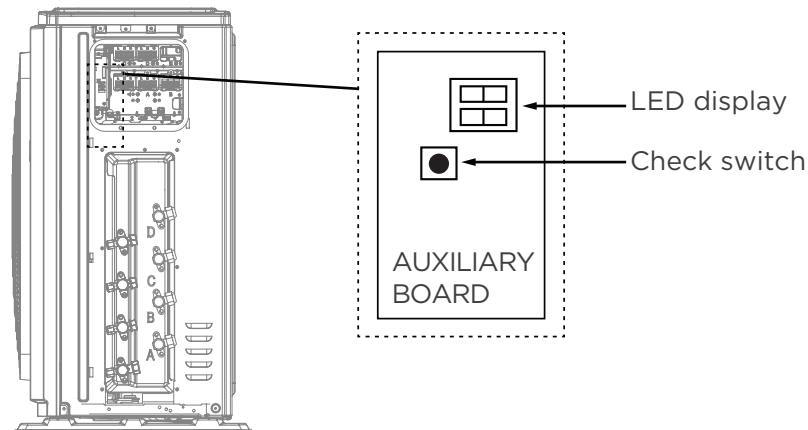

Correct

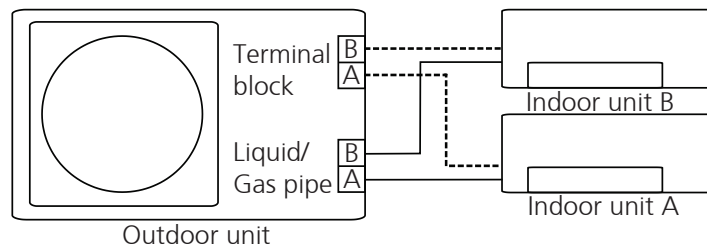

Incorrect wiring

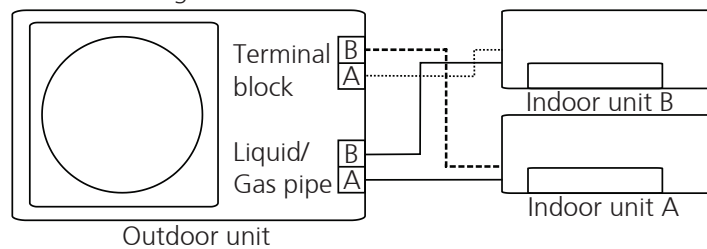

Incorrect wiring

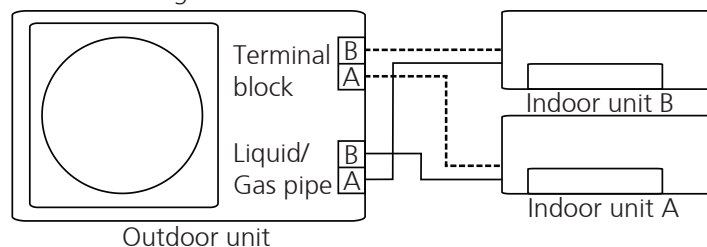

How To Activate This Function

1. Check that outside temperature is above 5°C.
(This function does not work when outside temperature is not above 5°C)
2. Check that the stop valves of the liquid pipe and gas pipe are open.
3. Turn on the breaker and wait at least 2 minutes.
4. Press the check switch on the outdoor PCB board unit LED display "CE".

CAUTION

About priority room function

The priority room function requires initial settings to be made during the installation of the unit. Ask the customer in which rooms he plans to use this function and make the necessary settings during installation.

Room cooling/heating priority

Room cooling/heating priority level order is arranged according to the outdoor unit A, B, C, that is, when A, B, C three systems have indoor units, the A system has the highest priority level, or when B, C two systems have indoor units, the B system has the highest priority level, the unit operates according to the mode set by the indoor unit system with the highest priority level, and the other rooms with indoor units in the same mode as the unit will operate, and if they are different, they will not operate, and display Mode Conflict.

NOTE: The above priority levels are valid only between air conditioners.

Air Conditioning or domestic hot water priority

When multiple indoor units are connected to the outdoor unit (refer to Installer Reference Guide for details), the user can set on the user interface whether to put DHW or Air Conditioning (A/C) as priority. This will determine how the outdoor unit will react in case multiple indoor units requested operation at the same time:

- If DHW is set as priority, outdoor unit can decide to operate only for DHW, while A/C operation is put on hold. In this case, once DHW operation is finished, outdoor unit can switch to A/C operation.
- If A/C is set as priority, outdoor unit can decide to operate only A/C, in which case booster heater can start for DHW production. Once A/C operation is finished, outdoor unit can switch to DHW.

NOTE: The unit is shipped from the factory with air conditioning priority by default. If, however, this needs to be changed please consult the water tank instruction manual.

⚠ CAUTION

About active heat recovery function

The active heat recovery and water tank energy storage function requires initial settings to be made during the installation of the unit. Ask the customer in which rooms he plans to use this function and make the necessary settings during installation.

Active heat recovery function

When multiple indoor units are connected to the outdoor unit (refer to Installer Reference Guide for details), users can choose to turn on or off the function. This will determine that users do not need to worry about how to set the water temperature when using air conditioning for cooling, and the unit may intelligently decide to recover more waste heat:

If the active heat recovery function is turned on, the outdoor unit can automatically store the waste heat in the water tank intelligently based on the cooling waste heat situation and the real-time water temperature of the water tank.

If the active heat recovery function is turned off, only when the air conditioning cooling and DHW are running simultaneously, can the cooling waste heat be stored in the water tank.

NOTE: The active heat recovery function is turned off by default when the device leaves the factory. If, however, this needs to be changed please consult the water tank instruction manual.

OPERATION INSTRUCTIONS

Features

Protection of the air conditioner

Compressor protection

- The compressor cannot restart for 3 minutes after it stops.

Anti-cold air

- The unit is designed not to blow cold air on HEAT mode, when the indoor heat exchanger is in one of the following three situations and the set temperature has not been reached.
 - A) When heating has just started.
 - B) During defrosting.
 - C) Low temperature heating.
- The indoor or outdoor fan stop running when defrosting (Cooling and heating models only).

Defrosting

- Frost may be generated on the outdoor unit during a heat cycle when outdoor temperature is low and humidity is high resulting in lower heating efficiency in the air conditioner.
- Under these conditions, the air conditioner will stop heating operations and start defrosting automatically.
- The time to defrost may vary from 4 to 10 minutes, depending the outdoor temperature and the amount of frost buildup on the outdoor unit.

Auto-Restart

In case of power failure, the system will immediately stop. When power returns, the Operation light on the indoor unit will flash. To restart the unit, press the **ON/OFF** button on the remote control. If the system has an auto restart function, the unit will restart using the same settings.

The air conditioner turns to FAN ONLY mode from COOL or HEAT mode

When all indoor temperature reaches the set temperature setting, the compressor will stop automatically, and the air conditioner turns to FAN only mode. The compressor will start again when the indoor temperature rises on COOL mode or falls on HEAT mode to the set point.

Droplets of water may form on the surface of the indoor unit when cooling occurs in relatively high humidity (defined as higher than 80%). Adjust the horizontal louver to the maximum air outlet position and select HIGH fan speed.

White mist emerging from the indoor unit

- A white mist may be generated due to a large temperature difference between air inlet and air outlet on COOL mode in places with high relative humidity.
- A white mist may be generated due to moisture created in the defrosting process when the air conditioner restarts in HEAT mode operation after defrosting.

Noise coming from the air conditioner

- You may hear a low hissing sound when the compressor is running or has just stopped running. This sound is the sound of the refrigerant flowing or coming to a stop.
- You may also hear a low "squeaking" sound when the compressor is running or has just stopped running. This is caused by tempera heat expansion and cold contraction of the plastic parts in the unit when the temperature is changing.
- A noise may be heard due to the louver restoring itself to its original position when power is first turned on.

Dust blowing out from the indoor unit.

This is happening when the air conditioner has not been used for a long time or during its first use.

Smell emitting from the indoor unit.

This is caused by the indoor unit giving off smells permeated from building materials, furniture, or smoke.

Heating mode

The air conditioner draws in heat from the outdoor unit and releases it via the indoor unit during heating. When the outdoor temperature falls, heat drawn in by the air conditioner decreases accordingly. At the same time, heat loading of the air conditioner increases due to larger difference between indoor and outdoor temperature. If a comfortable temperature cannot be achieved with the air conditioner alone, it is recommended that you use a supplementary heating device. Lightning or a car wireless telephone operating nearby may cause the unit to malfunction. Disconnect the unit from its power source and then re-connect the unit with the power source again. Push the ON/OFF button on the remote controller to restart operations.

Energy Saving Tips

- **DO NOT** set the unit to excessive temperature levels.
- While cooling, close the curtains to avoid direct sunlight.
- Doors and windows should be kept closed to keep cool or warm air in the room.
- **DO NOT** place objects near the air inlet and outlet of the unit. This will reduce the efficiency of the unit.
- Set a timer and use the built-in SLEEP/ECONOMY mode if applicable.
- If you don't plan to use the unit for a long time, remove the batteries from the remote control.
- Clean the air filter every two weeks. A dirty filter can reduce cooling or heating efficiency.
- Adjust louvers properly and avoid direct airflow.

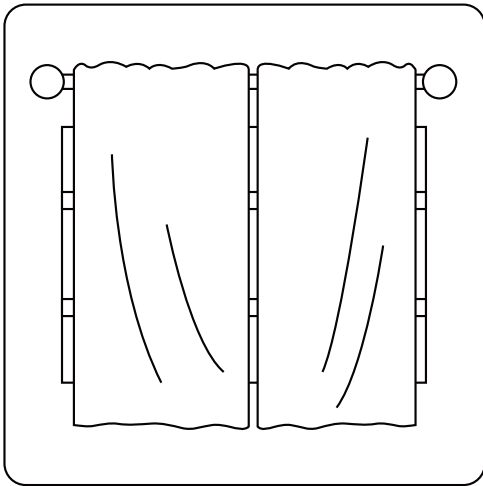

Closing curtains during heating also helps keep the heat in

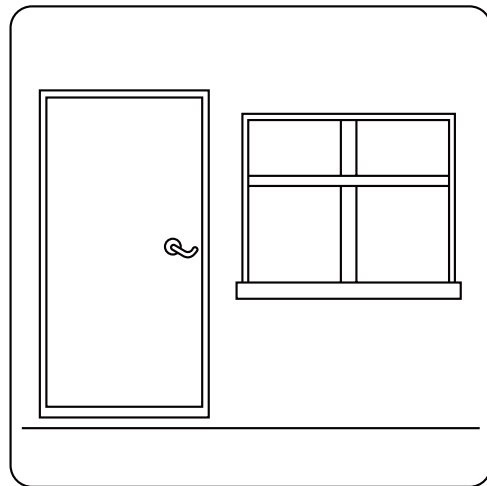

Doors and windows should be kept closed

MANUAL OPERATIONS & MAINTENANCE

Operation mode selection

While two or more indoor units are simultaneously operating, make sure the modes do not conflict with each other. The heat mode claims precedence over all other modes. If the unit initially started to operate in HEAT mode, the other units can operate in HEAT mode only. For example: If the unit initially started operates under COOL (or FAN) mode, the other units can operate under any mode except HEAT. If one of the units selects HEAT mode, the other operating units will stop operation and display "--" (for units with display window only) or the auto and operation indication light will flash rapidly, the defrost indication light will turn off, and the timer indication light will remain on (for units without a display window). Alternatively, the defrost and alarm indication light (if applicable) will light up, or the operation indication light will flash rapidly, and the timer indication light will turn off (for the floor and standing type).

Maintenance

If you plan to leave the unit idle for a long time, perform the following tasks:

1. Clean the indoor unit and air filter.
2. Select FAN ONLY mode and let the indoor fan run for a time to dry the inside of the unit.
3. Disconnect the power supply and remove the battery from the remote control.
4. Check components of the outdoor unit periodically. Contact a local dealer or a customer service centre if the unit requires servicing.
5. servicing shall be performed only as recommended by the manufacturer.
6. Qualification of workers
The manual shall contain specific information about the required qualification of the working personnel for maintenance, service and repair operations. Every working procedure that affects safety means shall only be carried out by competent persons according to Annex HH. Examples for such working procedures are:
 - breaking into the refrigerating circuit;
 - opening of sealed components;
 - opening of ventilated enclosures.

NOTE: Before you clean the air conditioner, be sure to switch off the unit and disconnect the power supply plug.

Optimal operation

To achieve optimal performance, please note the following:

- Adjust the direction of the air flow so that it is not blowing directly on people.
- Adjust the temperature to achieve the highest possible level of comfort. Do not adjust the unit to excessive temperature levels.
- Close doors and windows in COOL mode or HEAT mode.
- Use the TIMER ON button on the remote controller to select a time you want to start your air conditioner.
- Do not place any object near the air inlet or air outlet, as the efficiency of the air conditioner may be reduced and the air conditioner may stop running.
- Clean the air filter periodically, otherwise cooling or heating performance may be reduced.
- Do not operate unit with horizontal louvre in closed position.

Suggestion:

For units that feature an electric heater, when the outside ambient temperature is below 0°C (32°F), it is strongly recommended that you to keep the machine plugged in so as to guarantee smooth operation.

When the air conditioner is to be used again:

- Use a dry cloth to wipe off the dust accumulated on the rear air intake grille in order to avoid the dust being dispersed from the indoor unit.
- Check that the wiring is not broken off or disconnected.
- Check that the air filter is installed.
- Check if the air outlet or inlet is blocked after the air conditioner has not been used for a long time.

TROUBLESHOOTING

CAUTION

If any of the following conditions occurs, turn off your unit immediately!

- The power cord is damaged or abnormally warm
- You smell a burning odor
- The unit emits loud or abnormal sounds
- A power fuse blows or the circuit breaker frequently trips
- Water or other objects fall into or out of the unit

DO NOT ATTEMPT TO FIX THESE YOURSELF! CONTACT AN AUTHORIZED SERVICE PROVIDER IMMEDIATELY.

Common Issues

The following problems are not a malfunction and in most situations will not require repairs.

Issue	Possible Causes
Unit does not turn on when pressing ON/OFF button	The Unit has a 3-minute protection feature that prevents the unit from overloading. The unit cannot be restarted within three minutes of being turned off.
	Cooling and Heating Models: If the Operation light and PRE-DEF (Pre-heating/Defrost) indicators are lit up, the outdoor temperature is too cold and the unit's anti-cold wind is activated in order to defrost the unit.
The unit changes from COOL/HEAT mode to FAN mode	The unit may change its setting to prevent frost from forming on the unit. Once the temperature increases, the unit will start operating in the previously selected mode again.
	The set temperature has been reached, at which point the unit turns off the compressor. The unit will continue operating when the temperature fluctuates again.
The indoor unit emits white mist	In humid regions, a large temperature difference between the room's air and the conditioned air can cause white mist.
Both the indoor and outdoor units emit white mist	When the unit restarts in HEAT mode after defrosting, white mist may be emitted due to moisture generated from the defrosting process.
The indoor unit makes noises	A squeaking sound is heard when the system is OFF or in COOL mode. The noise is also heard when the drain pump (optional) is in operation.
	A squeaking sound may occur after running the unit in HEAT mode due to expansion and contraction of the unit's plastic parts.
Both the indoor unit and outdoor unit make noises	A low hissing sound may occur during operation. This is normal and is caused by refrigerant gas flowing through both the indoor and outdoor units.
	A low hissing sound may be heard when the system starts, has just stopped running or is defrosting. This noise is normal and is caused by the refrigerant gas stopping or changing direction.

The design and specifications are subject to change without prior notice for product improvement. Consult with the sales agency or manufacturer for details. Any updates to the manual will be uploaded to the service website, please check for the latest version.



Kaysun
by **frigicoll**

MAIN OFFICE

Blasco de Garay, 4-6
08960 Sant Just Desvern
(Barcelona)
Tel. +34 93 480 33 22
<http://www.frigicoll.es/>
<http://www.kaysun.es/en/>

MADRID

Senda Galiana, 1
Polígono Industrial Coslada
Coslada (Madrid)
Tel. +34 91 669 97 01
Fax. +34 91 674 21 00
madrid@frigicoll.es