

INSTALLATION MANUAL

Aquantia HT HP Large

KEM-50 DPS6 KH

KEM-60 DPS6 KH

KEM-70 DPS6 KH



Original manual.

Please read this Manual carefully and keep it properly for future reference. All the pictures in this Manual are for reference only.

CONTENTS

1 INTRODUCTION	01
• 1.1 Safety precautions	01
1.1.1 General description	01
1.1.2 Target group	02
1.1.3 Safety precaution about the appliances using flammable refrigerant	02
1.1.4 Intended use	05
1.1.5 Regulations to be observed	06
1.1.6 Safety instructions for working on the system	06
1.1.7 Installation	08
1.1.8 Safety instructions for operating the system	09
1.1.9 Disposal	10
• 1.2 General description	10
• 1.3 Refrigerant information	11
• 1.4 Use	11
• 1.5 Installation	11
• 1.6 Unit description	12
1.6.1 Dimension (mm)	12
1.6.2 Main components of the unit	13
1.6.3 Accessories	14
2 RECEIVING UNIT	15
3 UNIT STORAGE	15
4 MACHINE INSTALLATION	15
• 4.1 Safety	15
• 4.2 Safety zone	15
• 4.3 Handling and lifting	16
• 4.4 Positioning and assembly	17
4.4.1 Foundation structure	17
4.4.2 Foundation installation location	18
4.4.3 Installation of the unit damping devices	18
4.4.4 Installation of wind and snow protection devices	19
• 4.5 Minimum space requirements	20
• 4.6 Sound and voice protection	21
• 4.7 Water circuit connection of the unit	21
4.7.1 Water pipes	21
4.7.2 Water pipe connection	22
4.7.3 Y-type filter	24
4.7.4 System water flow rate	25
4.7.5 Selection of water tanks	25
4.7.6 Selection and installation of pumps	26
4.7.7 Water quality requirements	27
4.7.8 Selection of pipe diameters	27

4.7.9	Single pump or multiple pump installation	28
4.7.10	Expansion tank design	28
4.7.11	Selection of auxiliary electric heaters	29
4.7.12	Water system diagram	30
4.7.13	Capacity correction	32
4.7.14	Operating range	34
5	ELECTRICAL INSTALLATION	35
• 5.1	General specifications	35
• 5.2	Electrical supply	35
• 5.3	Electrical connections	36
5.3.1	Safety precautions	36
5.3.2	Electric wiring	37
5.3.3	Power connection requirements	40
5.3.4	Power cable wiring requirements	41
5.3.5	Overall	42
5.3.6	Function of terminals	44
5.3.7	Wiring of "ON/OFF" weak electric port	44
5.3.8	Wiring of "HEAT/COOL" weak electric port	44
5.3.9	Wiring of "TEMP-SWITCH" weak electric port	45
5.3.10	Wiring of "ALARM" port	45
5.3.11	Control system and installation precautions	45
• 5.4	PCB	46
• 5.5	DIP switch settings description	49
6	RESPONSIBILITIES OF OPERATORS	51
7	MAINTENANCE	52
• 7.1	Routine maintenance	52
• 7.2	Maintenance of air-side heat exchangers	53
• 7.3	Removing scale	53
• 7.4	Anti-freeze protection	54
7.4.1	Water flow switch anti-freezing	54
• 7.5	Cooling system protection	54
• 7.6	Electrical maintenance	55
• 7.7	Maintenance of sealed electric control box	55
• 7.8	Service and warranty period	56
• 7.9	Fault codes	58
8	FIRST STARTUP CHECK	60
• 8.1	Precautions before first startup	60
• 8.2	Commissioning	62
9	LOOP CIRCUIT	63
10	REFRIGERANT CHARGE INFORMATION	63
11	REGULAR INSPECTION AND ADJUSTMENT OF PRESSURE EQUIPMENT	64
12	DECOMMISSIONING AND DISPOSAL	64
13	SERVICE LIFE	64
14	TECHNOLOGY DATA	65

1 INTRODUCTION

This Manual provides standard function and procedure information for all units in this series. It is an important support document for unit operators and technical personnel, but it cannot replace professionals.

In the event of any inconsistency between this Manual and the accompanying document, the latter shall prevail.

Before installing and starting up the unit, please read this Manual carefully.

Improper installation may lead to electric shock, short circuit, leakage, fire, machine damage or personal injury.

The unit must be installed by professional operators and technicians in accordance with the current laws of the country of installation.

The startup of the unit must also be carried out by authorized and trained personnel, and all actions must fully comply with local laws and regulations.

If the instructions in this Manual are not clear, installation and startup will be strictly prohibited.

If you need assistance or more information, please contact your local service provider.

1.1 Safety precautions

1.1.1 General description

- 1) Install the unit in accordance with the instructions in this Manual.
- 2) Carry out all the maintenance operations specified in this Manual on a regular basis.
- 3) Wear appropriate protective equipment for the current work (gloves, goggles, helmets, etc.); do not wear clothing or accessories that may be drawn in or sucked in by the air flow; tie up long hair before contacting the unit.
- 4) Before opening the equipment panel, make sure it is securely hinged to the equipment.
- 5) The fins and the edges of the metal parts and panels may cause cuts.
- 6) When the unit is running, it is prohibited to remove the protective covers from moving parts; before restarting the unit, ensuring that the protective covers of moving parts have been correctly installed.
- 7) Fans and motors may be running: Before installation, be sure to wait for these components to stop and take appropriate measures to prevent them from starting.
- 8) The surfaces of equipment and pipes may become extremely hot or cold, posing a risk of burns or cold injury.
- 9) Do not overrun the maximum pressure limit of the unit's water circuit.
- 10) Before removing the components of the pressurized water circuit, close the relevant pipe sections and gradually drain the liquid to stabilize the pressure at atmospheric level.
- 11) Do not check for possible leakage with your hands.
- 12) Before opening the electric control box, make sure the unit has been disconnected from the power supply.
- 13) Before starting the unit, check whether it has been correctly grounded.

14) Install the equipment in a suitable area.

15) Do not use cables or extension cords with insufficient cross-sectional area for connection.

16) When disconnecting the main power supply of the unit, wait at least 10 minutes before maintenance can be carried out: it is necessary to take at least such a long period of time to discharge the residual charge in components; otherwise, there will be a risk of electric shock.

17) The unit contains pressurized refrigerant gas: except for maintenance, do not touch the pressurized equipment, and maintenance work must be carried out by qualified and authorized personnel.

18) Connect the utilities according to this Manual and the instructions on the unit panel.

19) To avoid environmental risks, please ensure that any leaked liquid is collected in appropriate containers and comply with local regulations.

20) If it is necessary to remove a certain component, please ensure that it has been correctly reassembled before starting the unit.

21) When the current rules require the installation of fire extinguishing systems near equipment, please check whether these fire extinguishing systems are suitable for extinguishing fires involving electrical equipment, compressor lubricating oil and refrigerants.

22) When the unit is equipped with pressure relief devices (safety valves), when these valves are activated, the refrigerant gas will be released at high temperature and high speed; prevent the gas release from causing injury to personnel or damage to objects, and if necessary, discharge the gas in accordance with EN 378-3 and current local regulations.

23) Keep all safety devices in good working condition and have them inspected regularly as required by current laws.

24) Store all lubricants in appropriately labeled containers.

25) Do not store flammable liquids near the unit.

26) Welding or brazing shall only be carried out after all traces of lubricant oil have been removed; do not use flames or other heat sources near pipes containing refrigerant liquid.

27) Do not use open flames near the unit.

28) Mechanical equipment must be installed in a structure that complies with relevant laws, regulations and technical standards for protection against atmospheric discharge.

29) Do not bend or strike pipes containing pressurized fluids.

30) It is prohibited to walk on or place other objects on the equipment.

31) The user is responsible for a comprehensive assessment of the fire risk at the installation site (for example, calculating the fire load).

32) During transportation, the unit must be securely fastened to the vehicle's cargo bed to prevent it from moving or overturning.

33) The equipment must be transported in accordance with current regulations, taking into account the characteristics of the fluids inside it.

34) Improper transportation may damage the equipment and even cause the leakage of the refrigerant liquid. Before startup, the equipment must be checked for any leakage. If found, repairs shall be conducted accordingly.

35) The accidental leakage of refrigerant in a confined area may lead to oxygen deficiency, thus posing a risk of suffocation. According to EN 378-3 and local current regulations, the equipment must be installed in a well-ventilated environment.

36) The unit is not recommended to be installed indoors. For works with special requirements that requires indoor installation, it is necessary to have the manufacturer or service provider assess the risks before installation.

37) Basic safety regulations shall be observed before starting work.

DANGER

It indicates a hazard with a high level of risk which, if not avoided, will result in serious injury.

WARNING

It indicates a hazard with a medium level of risk which, if not avoided, could result in serious injury.

CAUTION

It indicates a hazard with a low level of risk which, if not avoided, could result in minor or moderate injury.

NOTE

Additional information.

1.1.2 Target group

WARNING

These instructions are exclusively intended for qualified contractors and authorized installers. Work on the refrigerant circuit with flammable refrigerant in safety group A3 may only be carried out by authorized heating contractors. These heating contractors must be trained in accordance with EN 378 Part 4 or IEC 60335-2-40, Section HH. The certificate of competence from an industry accredited body is required.

Brazing/soldering work on the refrigerant circuit may only be carried out by personnel certified in accordance with ISO 13585 and AD 2000, Datasheet HP 100 R. And only contractors qualified and certified for the processes can perform brazing/soldering work. The work must fall within the range of applications purchased and be carried out in accordance with the prescribed procedures. Soldering/brazing work on accumulator connections requires certification of personnel and processes by a notified body according to the Pressure Equipment Directive (2014/68/EU).

Work on electrical equipment may only be carried out by a qualified electrician.

Before initial commissioning, all safety related points must be checked by the particular certified heating contractors. The system must be commissioned by the system installer or a qualified

1.1.3 Safety precaution about the About the appliances using flammable refrigerant

WARNING





The following precautions should be complied with when installation, service, maintenance and repair, and decommissioning of appliances using flammable refrigerant.

General

This appliance employed A3 flammable refrigerant R290.

The appliance shall be stored so as to prevent mechanical damage from occurring.

Symbols

	WARNING	This symbol shows that this appliance used a flammable refrigerant. If the refrigerant is leaked and exposed to an external ignition source, there is a risk of fire.
	CAUTION	This symbol shows that the manual should be read carefully.
	CAUTION	This symbol shows that only a competent service personnel should be handling this equipment with reference to the technical manual.
	CAUTION	This symbol shows that information is available such as the operating manual or installation manual.

WARNING

Do not use means to accelerate the defrosting process or to clean, other than those recommended by the manufacturer.

The appliance shall be stored in a room without continuously operating ignition sources (for example: open flames, an operating gas appliance or an operating electric heater).

Do not pierce or burn.

Be aware that refrigerants might not contain an odour.

Installation

① Qualification of workers

WARNING

Refer to Target group described above.

Every working procedure that affects safety means shall only be carried out by competent persons.

Examples for such working procedures are:

- breaking into the refrigerating circuit;
- opening of sealed components;
- opening of ventilated enclosures.

② General

WARNING

Protection devices, piping and fittings shall be protected as far as possible against adverse environmental effects, for example the danger of water collecting and freezing in relief pipes or the accumulation of dirt and debris;

Provision shall be made for expansion and contraction of long runs of piping;

Piping in refrigerating systems shall be so designed and installed as to minimize the likelihood of hydraulic shock damaging the system;

Steel pipes and components shall be protected against corrosion with a rustproof coating before applying any insulation;

Information on servicing

① General

WARNING

Servicing shall be performed only as recommended by the manufacturer.

② Checks to the area

Prior to beginning work on systems containing flammable refrigerants, safety checks are necessary to ensure that the risk of ignition is minimised.

③ Work procedure

Work shall be undertaken under a controlled procedure so as to minimise the risk of a flammable gas or vapour being present while the work is being performed.

④ General work area

All maintenance staff and others working in the local area shall be instructed on the nature of work being carried out. Work in confined spaces shall be avoided.

The area around the workspace shall be sectioned off. Ensure that the conditions within the area have been made safe by control of flammable material.

⑤ Checking for presence of refrigerant

The area shall be checked with an appropriate refrigerant detector prior to and during work, to ensure the technician is aware of potentially toxic or flammable atmospheres. Ensure that the leak detection equipment being used is suitable for use with all applicable refrigerants, i.e. non-sparking, adequately sealed or intrinsically safe.

⑥ Presence of fire extinguisher

If any hot work is to be conducted on the refrigerating equipment or any associated parts, appropriate fire extinguishing equipment shall be available to hand. Have a dry powder or CO2 fire extinguisher adjacent to the charging area.

⑦ No ignition sources

No person carrying out work in relation to a refrigerating system which involves exposing any pipe work shall use any sources of ignition in such a manner that it can lead to the risk of fire or explosion. All possible ignition sources, including cigarette smoking, should be kept sufficiently far away from the site of installation, repairing, removing and disposal, during which refrigerant can possibly be released to the surrounding space. Prior to work taking place, the area around the equipment is to be surveyed to make sure that there are no flammable hazards or ignition risks. "No Smoking" signs shall be displayed.

⑧ Ventilated area

Ensure that the area is in the open or that it is adequately ventilated before breaking into the system or conducting any hot work. A degree of ventilation shall continue during the period that the work is carried out. The ventilation should safely disperse any released refrigerant and preferably expel it externally.

⑨ Checks to the refrigerating equipment

Where electrical components are being changed, they shall be fit for the purpose and to the correct specification. At all times the manufacturer's maintenance and service guidelines shall be followed. If in doubt, consult the manufacturer's technical department for assistance.

The following checks shall be applied to installations using flammable refrigerants:

- the refrigerant charge is in accordance with nameplate specification and complies with all applicable regulatory requirements;
- ensure the installation site is well-ventilated;
- if an indirect refrigerating circuit is being used, the secondary circuit shall be checked for the presence of refrigerant;
- marking to the equipment continues to be visible and legible. Markings and signs that are illegible shall be corrected;

– refrigerating pipe or components are installed in a position where they are unlikely to be exposed to any substance which can corrode refrigerant containing components, unless the components are constructed of materials which are inherently resistant to being corroded or are suitably protected against being so corroded.

⑩ Checks to electrical devices

Repair and maintenance to electrical components shall include initial safety checks and component inspection procedures. If a fault exists that could compromise safety, then no electrical supply shall be connected to the circuit until it is satisfactorily dealt with. If the fault cannot be corrected immediately but it is necessary to continue operation, an adequate temporary solution shall be used. This shall be reported to the owner of the equipment so all parties are advised.

Initial safety checks shall include:

- that capacitors are discharged: this shall be done in a safe manner to avoid possibility of sparking;
- that no live electrical components and wiring are exposed while charging, recovering or purging the system;
- that there is continuity of earth bonding.

Sealed electrical components

WARNING

Sealed electrical components shall not be repaired.

Cabling

Check that cabling will not be subject to wear, corrosion, excessive pressure, vibration, sharp edges or any other adverse environmental effects. The check shall also take into account the effects of aging or continual vibration from sources such as compressors or fans.

Detection of flammable refrigerants

Under no circumstances shall potential sources of ignition be used in the searching for or detection of refrigerant leaks. A halide torch (or any other detector using a naked flame) shall not be used.

The following leak detection methods are deemed acceptable for all refrigerant systems.

Electronic leak detectors may be used to detect refrigerant leaks but, in the case of flammable refrigerants, the sensitivity can be inadequate, or can need re-calibration. (Detection equipment shall be calibrated in a refrigerant-free area.) Ensure that the detector is not a potential source of ignition and is suitable for the refrigerant used. Leak detection equipment shall be set at a percentage of the LFL of the refrigerant and shall be calibrated to the refrigerant employed, and the appropriate percentage of gas (25 % maximum) is confirmed.

Leak detection fluids are also suitable for use with most refrigerants but the use of detergents containing chlorine shall be avoided as the chlorine can react with the refrigerant and corrode the copper pipe-work.

NOTE

Examples of leak detection methods are

- bubble method,
- fluorescent agent method.

If a leak is suspected, all naked flames shall be removed/extinguished.

If a leakage of refrigerant is found which requires brazing, all of the refrigerant shall be recovered from the system, or isolated (by means of shut-off valves) in a part of the system remote from the leak.

CAUTION

Oxygen free nitrogen (OFN) shall then be purged through the system both before and during the brazing process.

Refrigerant removal and circuit evacuation

When breaking into the refrigerant circuit to make repairs – or for any other purpose –

conventional procedures shall be used. However, for flammable refrigerants it is important that best practice is followed since flammability is a consideration. The following procedure shall be adhered to:

- safely remove refrigerant following local and national regulations;
- evacuate;
- purge the circuit with inert gas;
- evacuate;
- continuously flush with inert gas when using flame to open circuit;
- open the circuit.

The refrigerant charge shall be recovered into the correct recovery cylinders.

CAUTION

- An inert gas, specifically, is dry oxygen free nitrogen(OFN).
- The system shall be “flushed” with OFN to render the unit safe. This process may need to be repeated several times.
- Compressed air or oxygen shall not be used for purging refrigerant systems.
- Purging of the refrigerant circuit shall be achieved by breaking the vacuum in the system with inert gas and continuing to fill until the working pressure is achieved, then venting to atmosphere, and finally pulling down to a vacuum. This process shall be repeated until no refrigerant is within the system. The system shall be vented down to atmospheric pressure to enable work to take place.

CAUTION

This operation is absolutely vital if brazing operations on the pipework are to take place. Ensure that the outlet of the vacuum pump is not close to any potential ignition sources and that ventilation is available.

Charging procedures

In addition to conventional charging procedures, the following requirements shall be followed.

- Ensure that contamination of different refrigerants does not occur when using charging equipment. Hoses or lines shall be as short as possible to minimise the amount of refrigerant contained in them.
- Cylinders shall be kept in an appropriate position according to the instructions.
- Ensure that the refrigerating system is earthed prior to charging the system with refrigerant.
- Label the system when charging is complete (if not already labelled).
- Extreme care shall be taken not to overfill the refrigerating system.

Prior to recharging the system, it shall be pressure-tested with the appropriate purging gas. The system shall be leak-tested on completion of charging but prior to commissioning. A follow up leak test shall be carried out prior to leaving the site.

Decommissioning

Before carrying out this procedure, it is essential that the technician is completely familiar with the equipment and all its detail. It is recommended good practice that all refrigerants are recovered safely. Prior to the task being carried out, an oil and refrigerant sample shall be taken

in case analysis is required prior to re-use of recovered refrigerant. It is essential that electrical power is available before the task is commenced.

- 1) Become familiar with the equipment and its operation.
- 2) Isolate system electrically.
- 3) Before attempting the procedure, ensure that:
 - a) mechanical handling equipment is available, if required, for handling refrigerant cylinders;
 - b) all personal protective equipment is available and being used correctly;
 - c) the recovery process is supervised at all times by a competent person;
 - d) recovery equipment and cylinders conform to the appropriate standards.
- 4) Pump down refrigerant system, if possible.
- 5) If a vacuum is not possible, make a manifold so that refrigerant can be removed from various parts of the system.
- 6) Make sure that the cylinder is situated on the scales before recovery takes place.
- 7) Start the recovery machine and operate in accordance with instructions.
- 8) Do not overfill cylinders (no more than 80 % volume liquid charge).
- 9) Do not exceed the maximum working pressure of the cylinder, even temporarily.
- 10) When the cylinders have been filled correctly and the process completed, make sure that the cylinders and the equipment are removed from site promptly and all isolation valves on the equipment are closed off.
- 11) Recovered refrigerant shall not be charged into another refrigerating system unless it has been cleaned and checked.

Labelling

Equipment shall be labelled stating that it has been de-commissioned and emptied of refrigerant. The label shall be dated and signed. For appliances containing flammable refrigerants, ensure that there are labels on the equipment stating the equipment contains flammable refrigerant.

Recovery

When removing refrigerant from a system, either for servicing or decommissioning, it is required to follow good practice so that all refrigerants are removed safely.

When transferring refrigerant into cylinders, ensure that only appropriate refrigerant recovery cylinders are employed. Ensure that the correct number of cylinders for holding the total system charge is available. All cylinders to be used are designated for the recovered refrigerant and labelled for that refrigerant (i.e. special cylinders for the recovery of refrigerant). Cylinders shall be complete with pressure-relief valve and associated shut-off valves in good working order. Empty recovery cylinders are evacuated and, if possible, cooled before recovery occurs.

The recovery equipment shall be in good working order with a set of instructions concerning the equipment that is at hand and shall be suitable for the recovery of the flammable refrigerant. Consult manufacturer if in doubt. In addition, a set of calibrated weighing scales shall be available and in good working order. Hoses shall be complete with leak-free disconnect couplings and in good condition. The recovered refrigerant shall be processed according to local legislation in the correct recovery cylinder, and the relevant waste transfer note arranged. Do not mix refrigerants in recovery units and especially not in cylinders.

If compressors or compressor oils are to be removed, ensure that they have been evacuated to an acceptable level to make certain that flammable refrigerant does not remain within the lubricant. The compressor body shall not be heated by an open flame or other ignition sources to accelerate this process. Draining of oil from a system shall be carried out safely.

1.1.4 Intended use

Improper or unintended use may result in injury or death to the user or others, or damage to the product and other property.

This product is an integrated air source heat pump.

The product uses outdoor air as a heat source and can be used for building heating and domestic hot water preparation. The air discharged from the equipment must be able to circulate freely and must not be used for any other purpose.

The unit is not recommended to be installed indoors. For works with special requirements that requires indoor installation, it is necessary to have the manufacturer or service provider assess the risks before installation.

The following sites are not suitable for installation:

- 1) Sites where mineral oil mists, oily sprays or oil vapors are present. Such environments may cause plastic component degradation, leading to potential risks of loose interfaces and water seepage.
- 2) Sites where corrosive gases (e.g. sulfur dioxide gas) are present. Such gases may cause corrosion to copper tubes or welded joints, leading to the risk of refrigerant leakage.
- 3) Sites where strong electromagnetic radiation equipment are present. High-intensity electromagnetic waves may interfere with the system control function and cause abnormal operation of the equipment.

4) Sites where there is leakage of flammable gas, carbon fiber or combustible dust suspended in the air, or where volatile flammable substances such as thinners or gasoline are handled. Such substances may cause fire accidents.

5) Sites with excessively high salt content in the air (e.g. coastal areas).

6) Sites with severe voltage fluctuations (e.g. inside factories)

7) Means of transportation (vehicles / vessels).

8) Sites where there is contamination by acidic or alkaline vapors.

The use of the product must comply with the following requirements:

1) To strictly follow the operation manual of this product and its accompanying components when performing tasks.

2) To fully implement all inspection and maintenance requirements set forth in the instruction manual.

3) The installation and commissioning process shall comply with the product certification and system access regulations.

4) This equipment shall be installed, commissioned, inspected, maintained and troubleshot by eligible contractors and authorized installers, including installation that complies with the IP protection grade requirements.

Children aged 8 and above, as well as individuals with physical, sensory or intellectual impairments or lacking experience and knowledge, may use this equipment under supervision under the safety instructions after understanding the potential risks. Children shall not use this machine as a toy. Children shall not perform machine cleaning and maintenance without witness.

Any use beyond the scope specified in this Manual (including direct commercial or industrial use) is regarded as improper use.

1.1.5 Regulations to be observed

Please strictly abide by the following regulations and requirements:

1) National installation regulations.

2) Legal regulations for accident prevention.

3) Legal regulations on environmental protection.

4) Legal requirements for pressure equipment: Pressure Equipment Directive 2014/68/EU

5) Industry norms of relevant industry associations.

6) Specific relevant safety regulations of various countries.

7) Relevant regulations and operation guidelines concerning the operation, maintenance, upkeep, repair and safety of cooling, air conditioning and heat pump systems containing flammable and explosive refrigerants.

1.1.6 Safety instructions for working on the system

This unit contains flammable refrigerant R290 (propane C3H8). If a leak occurs, the escaping refrigerant may form a flammable or explosive atmosphere in the surrounding air. The area immediately adjacent to the equipment is defined as a safety zone. Special regulations must be followed when working on the equipment.

Working in the zone

DANGER

- Explosion risk: Refrigerant leakage may form flammable or explosive mixtures in the surrounding air.

- Please take the following measures to assure fire and explosion prevention within the safety zone:

Keep away from all ignition sources, including open flames, power sockets, hot surfaces, light switches, lamps, and electrical appliances that may produce ignition sources, and mobile devices with built-in batteries (e.g. mobile phones and sports watches).

b. The use of aerosol sprays or other flammable gases is prohibited in the safety zone.

CAUTION

Permissible tools: All tools used in the safety zone must be designed and explosion-proof treated in accordance with the relevant standards and regulations applicable to A2L and A3 refrigerants, including but not limited to: brushless machines (e.g. cordless disposal containers, installation aids, and screwdrivers), vacuum equipment, vacuum pumps, conductive hoses, and mechanical tools made of non-sparking materials.

CAUTION

- The tools in use must be suitable for the current pressure range and kept in good maintenance condition.

- The electrical equipment must comply with the protection requirements for Zone 2 explosive hazardous area.

- The use of spray cans or other flammable gases and other flammable materials is prohibited.

- Before operations, static electricity shall be discharged by touching a grounded object, such as a radiator or water pipe.

- It is strictly prohibited to remove, block or short-circuit the safety devices.

- Any alterations are prohibited: Do not modify the unit, inlet and outlet pipelines, electrical connections/cables or the surrounding environment without authorization. Do not remove any components or seals.

Working in the system

When disconnecting the power supply of the equipment (including all accessories), please operate through an independent fuse or the main power supply disconnecter. Check and confirm that the system has been completely powered off.

CAUTION

In addition to the control circuit, there may be multiple power supply circuits.

DANGER

- Touching live parts may cause serious injury. Even when the power is off, some components on the printed circuit board (PCB) may still be charged. Before removing the equipment enclosure, please wait for at least 10 minutes until the voltage has completely dissipated.
- Make sure the system is in a state where it cannot be reconnected.
- When performing any operation, please wear appropriate personal protective equipment (PPE).
- Do not touch any switches or electrical components with wet hands, as this may cause electric shock and lead to system failure.

DANGER

- High-temperature surfaces and liquids may cause burns or scalds. Low-temperature surfaces may cause cold injury.
- Before repair or maintenance operations, please turn off the power and allow the equipment to cool down or warm up to the appropriate temperature.
- Do not touch the high or low temperature surfaces on the equipment body, accessories or piping system.

NOTE

Electronic components may be damaged by electrostatic discharge. Therefore, before operations, please touch grounded objects such as radiators or water pipes to discharge static electricity.

Safety work area and temporary flammability zone

CAUTION

When dealing with systems that use flammable refrigerants, technicians shall treat certain operation areas as "temporary flammability zones". Such areas typically refer to work areas where there may be trace emissions of refrigerants during regular operation procedures (e.g. refrigerant recovery, charging, and vacuuming operations), especially at operation points involving the connection or disconnection of hoses. Technical personnel shall ensure that a safety work area is established within a radius of 3 m around the equipment to deal with the potentially flammable air mixture of combustible gas that may form in case of accidental refrigerant leakage.

Working on the refrigerant circuit

R290 refrigerant (propane) is a gas that is air-displacing, colorless, flammable and odorless, and will form an explosive mixture when mixed with air. The discharged refrigerant must be properly handled by an authorized contractor. Before working on the refrigerant circuit, please take the following measures:

- Check whether there is any leakage in the refrigerant circuit.
- Ensure that the work area (especially the ground area) is well-ventilated and maintain this condition throughout the operation.
- Carry out safety isolation around the work area.
- Inform all relevant personnel, including all maintenance staff and those in the surrounding area, of the type of work to be carried out.
- Check whether there are flammable materials and ignition sources around the heat pump. Remove all flammable materials and ignition sources.
- Before, during, and after operations, use an explosion-proof refrigerant detector suitable for R290 (the detector must be spark-proof and properly sealed) to check the surrounding area for refrigerant leakage.
- Carbon dioxide or dry powder fire extinguishers must be provided in the following situations:
 - During the refrigerant discharge operation
 - During the refrigerant charging operation
 - During the brazing or welding operation
- No-smoking signs must be set up on site.
- All improper operations that may cause sparks, such as metal collisions, shall be avoided.

⚠ DANGER

During the charging and topping up of R290 refrigerant, it is essential to strictly ensure that there are no open flames, static sparks or high-power radio equipment in the surrounding area; the connection between the tank and the unit must be airtight to prevent refrigerant leakage; during the topping up process, the concentration of flammable gas needs to be monitored in real time; after the refrigerant charging or topping up is completed, the valves of the unit and the tank shall be locked.

⚠ DANGER

- Refrigerant leakage may cause fire or explosion, resulting in serious injury or even death.
- Drilling or heating on the refrigerant pipeline filled with refrigerant is strictly prohibited.
- Do not operate Schrader valves unless they are connected to a charging valve or a vacuum pump.
- Safety precautions:
 - a. Anti-static measures must be taken.
 - b. No Smoking.
 - c. No exposure to open flames and sparks.
 - d. Do not switch on or off lamps or electrical appliances in an environment where there are open flames or sparks.
 - e. Components that contain or have contained refrigerants must be marked and stored in well-ventilated areas in accordance with relevant regulations and standards.
 - f. High-power radio equipment is prohibited.

⚠ DANGER

- Direct exposure to liquid or gaseous refrigerants may cause serious harm to health, such as cold injury and/or burns. Inhaling refrigerant gas poses a risk of suffocation.
- Do not contact with liquid or gaseous refrigerants directly.
- PPEs must be used when handling refrigerants.
- Do not inhale any refrigerant vapor.

⚠ DANGER

Applying mechanical loads to the pipelines and components may cause leakage in the refrigerant circuit. It is strictly prohibited to apply any load to the pipelines or components (e.g. using them as supports or placing tools on them).

⚠ DANGER

The metal surfaces in the refrigerant circuit may be at high or low temperatures; exposure to skin may cause burns or cold injury. Please wear PPEs to prevent such injuries.

⚠ DANGER

If the refrigerant circuit is damaged, it may cause the refrigerant to enter the hydraulic system. After the operations, please properly release the air from the hydraulic system. When operating, ensure that the work area is well ventilated.

💡 NOTE

In the process of removing the refrigerant, the hydraulic components may freeze. Therefore, the heating water in the heat pump needs to be drained in advance.

1.1.7 Installation

① General

Only the specified accessories and components can be used during installation. Using non-specified components may cause water leakage, electric shock, fire or the equipment to fall from the base.

Please install the equipment on a base that can bear its weight. Insufficient structural strength may cause the equipment to fall and result in personal injury.

When carrying out installation operations, factors such as strong winds, hurricanes or earthquakes shall be fully taken into account. Improper installation may lead to equipment falling accidents.

The power cord shall be kept at least 3 ft (1 m) away from the television or radio to avoid signal interference. (Depending on the electromagnetic wave conditions, a distance of 3 ft may not be sufficient to completely eliminate interference).

Any damaged power cord must be replaced by the manufacturer or its authorized service personnel or a person with equivalent qualifications to eliminate potential safety hazards.

⚠ CAUTION

- No exhaust valves shall be installed indoors. Ensure that the outlet of the indoor safety valve leads to the outdoor space.
- For outdoor installation, the following two scenarios need to be considered to prevent system damage, leakage and adverse consequences:
 - a. If the equipment is located in an area accessible to the public;
 - b. The equipment is located in a restricted area and only allows authorized personnel to enter.

⚠ DANGER



Inflammable matters are prohibited.

DANGER



Open flames, fires, open ignition sources and smoking are prohibited.

CAUTION

- Freezing may cause damage to the heat pump system.
- All hydraulic pipelines need to be insulated for protection.
- The filling of antifreeze in the secondary circuit shall comply with local regulations and technical standards.

③ Connecting cables

CAUTION

If the electrical line is too short, when a leakage occurs in the refrigerant circuit, gaseous refrigerant may enter the building.

④ General work area

CAUTION

- Repairing components with safety functions may compromise the safe operation of the system.
- When replacing faulty components, be sure to use genuine spare parts provided by the manufacturer.
- Any maintenance operations on the inverter are strictly prohibited. Please replace the faulty inverter, if any, directly.
- Repair work shall not be performed on site, but in the designated area.

⑤ Auxiliary component, spare and wearing parts

CAUTION

Spare and wearing parts that have not been tested together with the system may affect the functionality of system. Installing unauthorized components, making unapproved modifications or alterations may compromise security and could result in the invalidation of the warranty. When replacing parts, please use only the original spare parts provided or approved by the manufacturer.

1.1.8 Safety instructions for operating the system

① What to do if refrigerant leaks

WARNING

To avoid potential risks caused by refrigerant leakage, please keep a safe distance of more than 2 m from the equipment (especially for children), regardless of whether the equipment is in operation or not.

DANGER

- Refrigerant leakage may cause fire and explosion, resulting in serious personal injury or death. Inhaling refrigerant may cause suffocation.
- It is essential to assure a good ventilation environment, with particular attention to the air circulation in the ground area around the outdoor unit.
- No smoking. No exposure to open flames and electric sparks. In environments with open flames or electric sparks, it is strictly prohibited to switch on or off lamps or any electrical equipment.
- Evacuate all personnel from the hazardous area immediately. Cut off the power supply of the entire system at a safe location.
- Eliminate all ignition sources in the hazardous area.
- System User Notice: During maintenance, it is strictly prohibited to bring any ignition sources into the hazardous area.
- Maintenance work must be carried out by authorized contractors.
- The equipment must not be restarted until the system has been repaired and passed the security verification.

CAUTION

- Direct exposure to liquid or gaseous refrigerants may cause serious harm to health, such as cold injury and/or burns. Inhaling liquid or gaseous refrigerant may cause suffocation.
- Do not directly contact with liquid or gaseous refrigerants.
- Do not inhale the refrigerant vapor.

② What to do if water leaks

DANGER

Water leakage in the equipment, if any, may cause electric shock. Please immediately turn off the heating system through an external isolator (e.g. a fuse box or household distribution box).

CAUTION

In the event of water leakage from the equipment, as the overflowing hot liquid may cause scalding danger, do not touch the hot water directly.

③ What to do if the outdoor unit ices up

CAUTION

- Ice formation in the condensate pan and the fan area of the outdoor unit may cause damage to the equipment.
- Mechanical tools or auxiliary equipment are prohibited for de-icing.
- Before using the electric heating device, it is necessary to use appropriate detection equipment to check whether the refrigerant circuit is leaking. The heating device shall not be a source of ignition and must comply with the requirements of EN 60335-2-30 standard.
- If the unit frequently freezes (e.g. in areas with frequent frost and thick fog), please install a fan ring heater (accessories) suitable for R290 refrigerant and/or add an electric heating tape in the condensate pan (customizable).

④ Safety instructions for storage of the unit

The unit has been charged with R290 refrigerant (propane) in the factory.

DANGER

- Refrigerant leakage may cause fire and explosion, resulting in serious personal injury or death. Inhaling refrigerant may cause suffocation. Please store the unit in the following environment:
- It is necessary to formulate and implement an explosion-proof storage plan.
- Ensure that the storage location is well-ventilated.
- Keep away from heat sources (no exposure to high temperatures and no smoking).
- The unit must be stored with the ex-factory protective packaging retained.
- Avoid damage to the equipment.
- The maximum storage quantity at the same location shall be determined based on the actual situation on site.

WARNING

When a fire is caused by R290 (propane), only carbon dioxide or dry powder fire extinguishers can be used to put it out.

1.1.9 Disposal

This equipment uses flammable refrigerants. The disposal of the equipment must comply with national regulations.

Do not dispose this product as unsorted municipal waste. Collection of such waste separately for special treatment is necessary.

Do not dispose of electrical appliances as unsorted municipal waste, and use separate collection facilities.

Contact your local government for information regarding the collection systems available.

If electrical appliances are disposed of in landfills or dumps, hazardous substances can leak into the groundwater and get into the food chain, damaging your health and well-being.



Caution: Risk of fire

1.2 General description

The outsourced equipment is a heat pump, a machine designed to cool/warm water (or water-glycol mixture) within a certain range, with the specific operating range mentioned below. This equipment runs based on the Carnot cycle principle, working through the compression, condensation and evaporation of refrigerant gas, mainly consisting of:

Two scroll compressors, raising the pressure of the refrigerant gas from the evaporation pressure to the condensation pressure.

One condenser, where the refrigerant gas condenses under high pressure and releases heat.

One expansion valve, allowing the pressure of the condensed liquid refrigerant to drop from the condensing pressure to the evaporating pressure.

One evaporator, where the low-pressure liquid refrigerant evaporates and absorbs heat.

The operation of the heat exchanger can be reversed through the four-way valve, thus enabling the heat pump to provide heating or cooling as required.

The Mars Large series base models include 50/60/70kW models. Unless otherwise specified, the instructions in this Manual apply to all models of this series. The instructions in this Manual apply to all models of this series, unless otherwise specified.

All devices have been assembled and tested before they leave the factory.

This equipment only applies to R290 refrigerant.

The equipment only needs to be connected to the water system, electrical system and other routine on-site systems. Installation has been streamlined and reliability, safety and system operation-related settings have all been completed in the factory.

Multilingual QR code



This Manual and other documents of the equipment shall be delivered to the end user. The completed documents include:

Document	Content	Format
Installation Manual (this Manual)	Installation instructions	Paper (placed in the box nearby the outdoor unit)
Operation Manual (for wired controller)	Quick guide for basic operations	Paper (placed in the box nearby the outdoor unit)
Technical Data Manual	Performance data and ERP information	Paper (placed in the box nearby the outdoor unit)

1.3 Refrigerant information

This product contains R290 refrigerant with a low global warming potential (GWP) and a minimal impact on the environment. According to ISO 817, R290 refrigerant is classified as A3 and is a highly flammable and explosive refrigerant. Its explosive limit when mixed with air is 2.1% to 9.5% by volume. It may cause combustion or explosion when exposed to open flames, static electricity or high temperatures. However, heat pumps used correctly in a normal working environment will not pose any risks.

Physical properties of R290

Safety level	A3
Molecular weight	44.1
Lower flammable limit (LFL) (vol %)	2.1
Boiling point (°C)	-42.1
ODP	0
GWP	3
Self-ignition temperature (°C)	470

1.4 Use

The unit is designed and manufactured for cooling/heating buildings or industrial processes. The first commissioning of the unit before it is put into use must be carried out by professional technicians who have received specialized training. Failure to follow this startup procedure will affect the warranty.

The standard warranty coverage for the unit includes parts that are defective in materials or workmanship. Materials consumed naturally are not covered by the warranty.

1.5 Installation

The unit is not recommended to be installed indoors. For works with special requirements that requires indoor installation, it is necessary to have the manufacturer or service provider assess the risks before installation.

The installation of the unit shall comply with local building codes and safety standards; in the absence of local codes and standards, EN 378-3 shall be referred to as a guide.

The unit shall prevent refrigerant leakage from entering buildings or otherwise endangering personnel and property.

In the event of a leakage incident, the refrigerant shall not flow into any fresh air inlets, doors, hatches or similar openings for ventilation. For installation in an open air, the site shall have natural or forced ventilation.

For installations in outdoor sites where refrigerant may accumulate (e.g. underground), the installation shall comply with the requirements for gas detection and ventilation in mechanical equipment rooms.

1.6 Unit description

1.6.1 Dimension (mm)

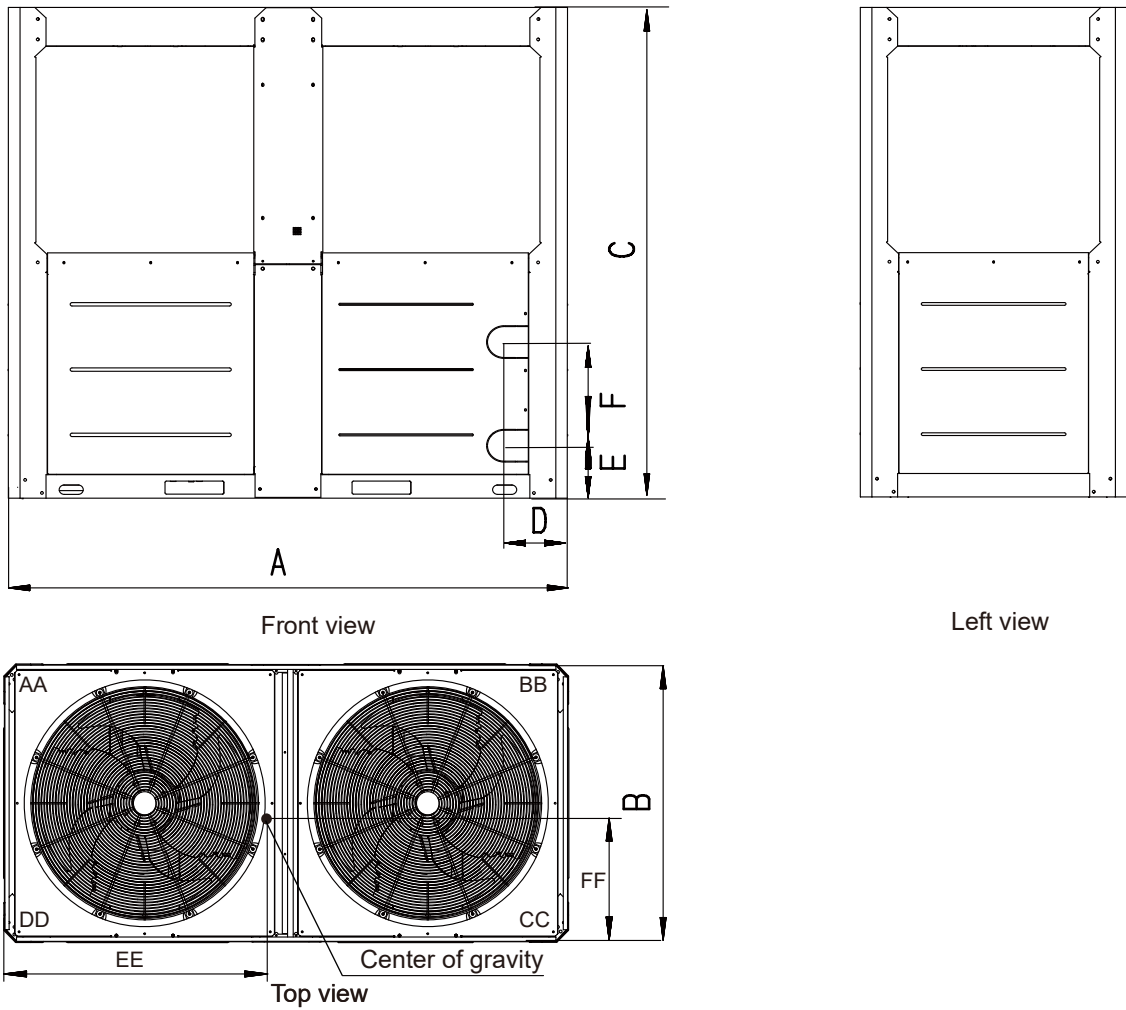

Fig. 1-1 Outline dimensional

Table 1-1

Model	50/60/70kW
A	2 000
B	960
C	1 870
D	226
E	200
F	397

	Model	50/60/70kW
CORNER GRAVITY (mm)	EE	1018
	FF	454
CORNER WEIGHTS (kg)	AA	120
	B8	171
	CC	142
	DD	182

NOTE

After the installation of the spring damper, the height of the unit will increase by approximately 135 mm.

1.6.2 Main components of the unit

Table 1-2

NO.	NAME	NO.	NAME
1	Air outlet	9	Water inlet
2	Top cover	10	Wired controller (It can be placed indoors)
3	Electric control box	11	Centralized drainage selectionpiece (Optional)
4	Compressor	11.1	heater band (Optional)
5	Plate heat exchanger	11.2	defrosting pan (Optional)
6	Heat exchanger	11.3	drain-pipe (Optional)
7	Water outlet	11.4	Tropical junction box (Optional)
8	Air inlet	12	Pump

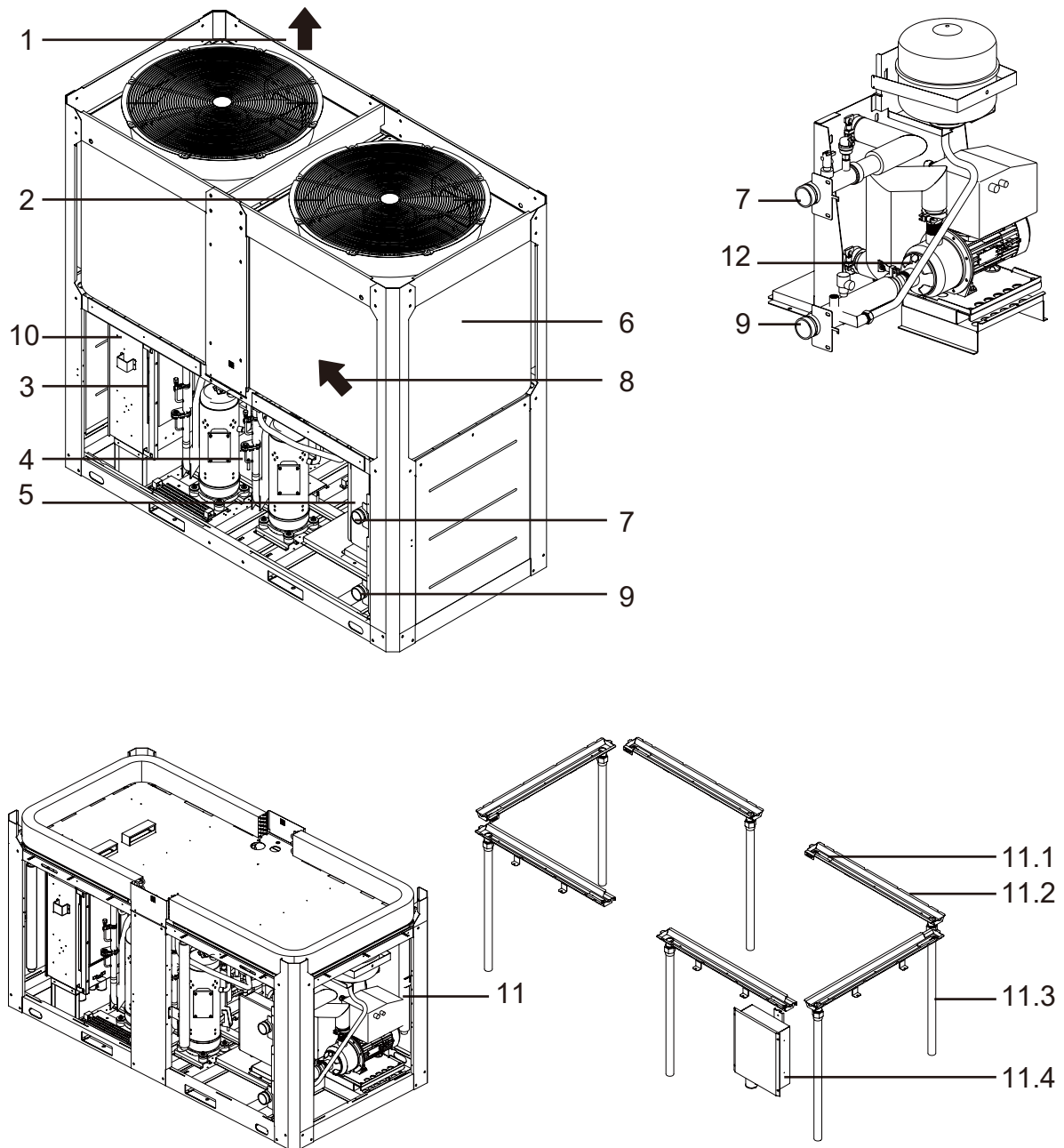

Fig. 1-2 Main parts of 50/60/70kW

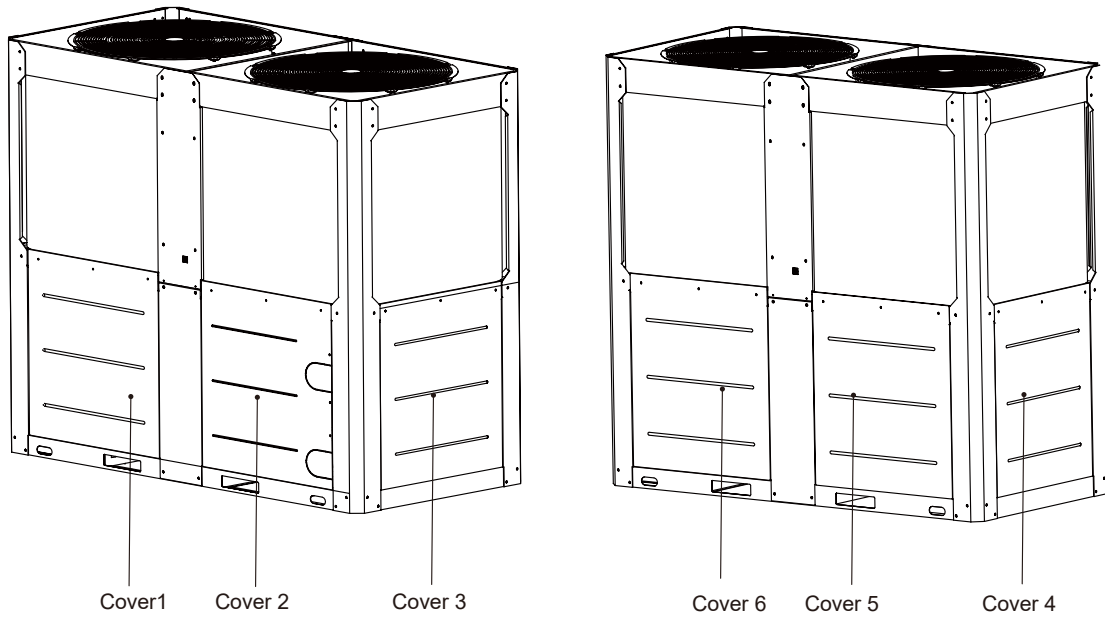

Fig. 1-3 Doors of 50/60/70kW

Covers 1, 2 and 3 are used for accessing and maintaining water pipes and water-side heat exchangers.









Cover 4 is used for opening and inspecting the electric control box.

Covers 5 and 6 are used for inspecting the system pipelines.

The above is for general maintenance situations. Please open the corresponding cover according to specific maintenance requirements.

1.6.3 Accessories

Table 1-3

Unit	Installation Manual	Installation connector of the total outlet water temperature sensor	Wired controller adapter	Installation Manual for the Wired Controller	Water temperature sensor	Wired controller	Magnetic ring	Zip ties
Quantity	1	1	1	1	1	1	1	7
Schematic Diagram								
Function	/	For installation only (for host settings only)						

Separately orderable accessories

Name	Specification
Spring shock absorber pad	MHS-160

2 RECEIVING UNIT

Check the unit once upon delivery. Make sure that all components of the equipment are intact, with no deformation caused by impact. If any damage is found upon receiving the equipment, do not remove the damaged materials and immediately file a written complaint with the transportation company, requesting an inspection of the unit; do not carry out any repairs until the transportation company representative has inspected it. Please report the damage to the manufacturer or supplier immediately. Taking photos will help determine responsibility.

All components described on the delivery note must be inspected and verified. Check whether the model, specification, quantity and accessories of the equipment are consistent with the contract. Please report problems, if any, to the manufacturer or supplier immediately.

Without the written consent of the manufacturer or supplier, please do not make any modifications to the equipment. We shall not be held responsible for any consequences arising therefrom.

We shall not be held responsible for any damage that the equipment may sustain during transportation to the destination.

When moving the unit, extreme care must be taken to prevent damage to the components.

Before installing the unit, the model and power supply voltage indicated on the nameplate shall be checked for correctness. After the unit is accepted by the customer, any damage cannot be attributed to the manufacturer.

3 UNIT STORAGE

If it is necessary to store the unit before installation, some precautions must be observed:

- Do not remove the protective plastic;
- Protect the unit from dust, bad weather and any rodents;
- Do not expose the unit to direct sunlight;
- Do not use heat sources or open flames near the unit.

Storage environmental conditions must be within the following range:

Minimum environment temperature: -25°C

Maximum environment temperature: $+48^{\circ}\text{C}$

Maximum relative humidity: 95% non-condensing

Storage at temperatures lower than the minimum may damage components, while storage at temperatures higher than the maximum will cause the safety valve to open, resulting in refrigerant leakage. Storing in a damp environment may damage the electrical components.

4 Machine Installation

4.1 Safety

Before installing and commissioning the equipment, the personnel involved in this activity must have obtained the necessary information to perform these operations and applied all the information collected in this Manual. Especially:

When the unit cannot be moved, it must be firmly fixed to the ground;

The unit can only be lifted using the designated lifting points provided at its bottom;

The personnel who carry out activities must be provided with PPEs. Common PPEs include helmets, glasses, gloves, earplugs, safety shoes, etc.

After a thorough analysis of the specific risks in the relevant areas, further personal and collective protective measures must be taken in accordance with the activities to be carried out.

4.2 Safety zone

According to the provisions of ISO 817 and ANSI/ASHRAE 34 standards, the refrigerant circuit of the outdoor unit contains highly flammable refrigerants of safety group A3. Therefore, a safety zone must be immediately demarcated around the outdoor unit and special requirements must be implemented. This refrigerant has a density greater than that of air. In the event of a leakage incident, the spilled refrigerant may accumulate near the ground. The following situations must be avoided within the safety zone:

Building openings: windows, door bodies, light wells, skylights on flat roofs, etc.;

Outdoor air inlets and outlets of the ventilation and air conditioning system;

Property boundary lines, adjacent property areas, pedestrian walkways, and vehicle lanes;

Pump well facilities, sewage system inlets, rainwater downspouts, sewage shafts, etc.

Other ramps, grooves, depressed areas and various types of shafts;

Residential power supply connection point;

Electrical system (including sockets, lamps and lighting switches);

Roof snow accumulation area;

Open flame source or burner metal wire mesh assembly;

Barbecue device;

Tools that are prone to generating sparks;

Electrical equipment with ignition sources;

The following ignition sources are strictly prohibited from being introduced into the safety zone:

Mobile devices with built-in batteries (e.g. mobile phones, sports watches);

Objects with a temperature exceeding 360°C .

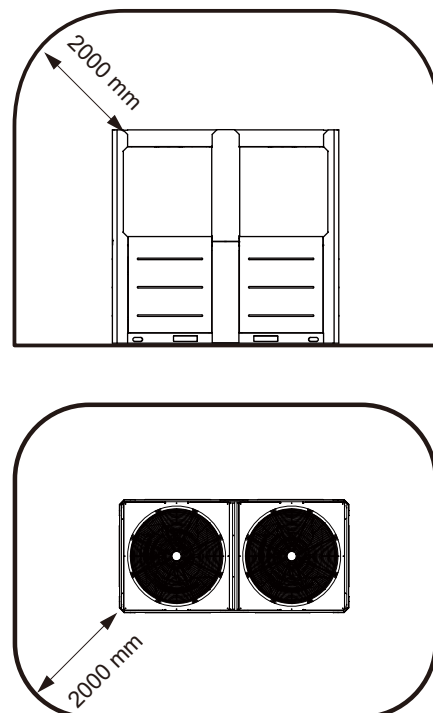

Fig. 4-1 Floor-standing safety zone

4.3 Handling and lifting

When handling and moving the unit on the truck, it is necessary to avoid collision or vibration. Do not push or pull the unit from any part other than the base frame. When fixing the unit in the truck, it is necessary to prevent it from moving and damage. During transportation or handling, no part of the unit is allowed to fall.

All units in this series are equipped with identified lifting points. Only these points can be used for lifting the unit, as shown in the following figure.

When moving equipment, all necessary devices must be provided to assure personal safety.

Machine, ropes, lifting accessories, and handling procedures must comply with local regulations and current requirements.

Only hooks with locking devices can be used. The hook must be firmly fixed before handling.

The lifting ropes, hooks and spacing rods must be strong enough to safely support the unit. Please check the weight of the unit on the nameplate of the unit.

Installers are responsible for ensuring the selection and correct use of lifting equipment. However, it is recommended to use a rope with a vertical load-bearing capacity of at least equal to the total weight of the equipment. The equipment must be lifted with great care and attention strictly in accordance with the instructions on the lifting label; it must be lifted slowly and kept completely level.

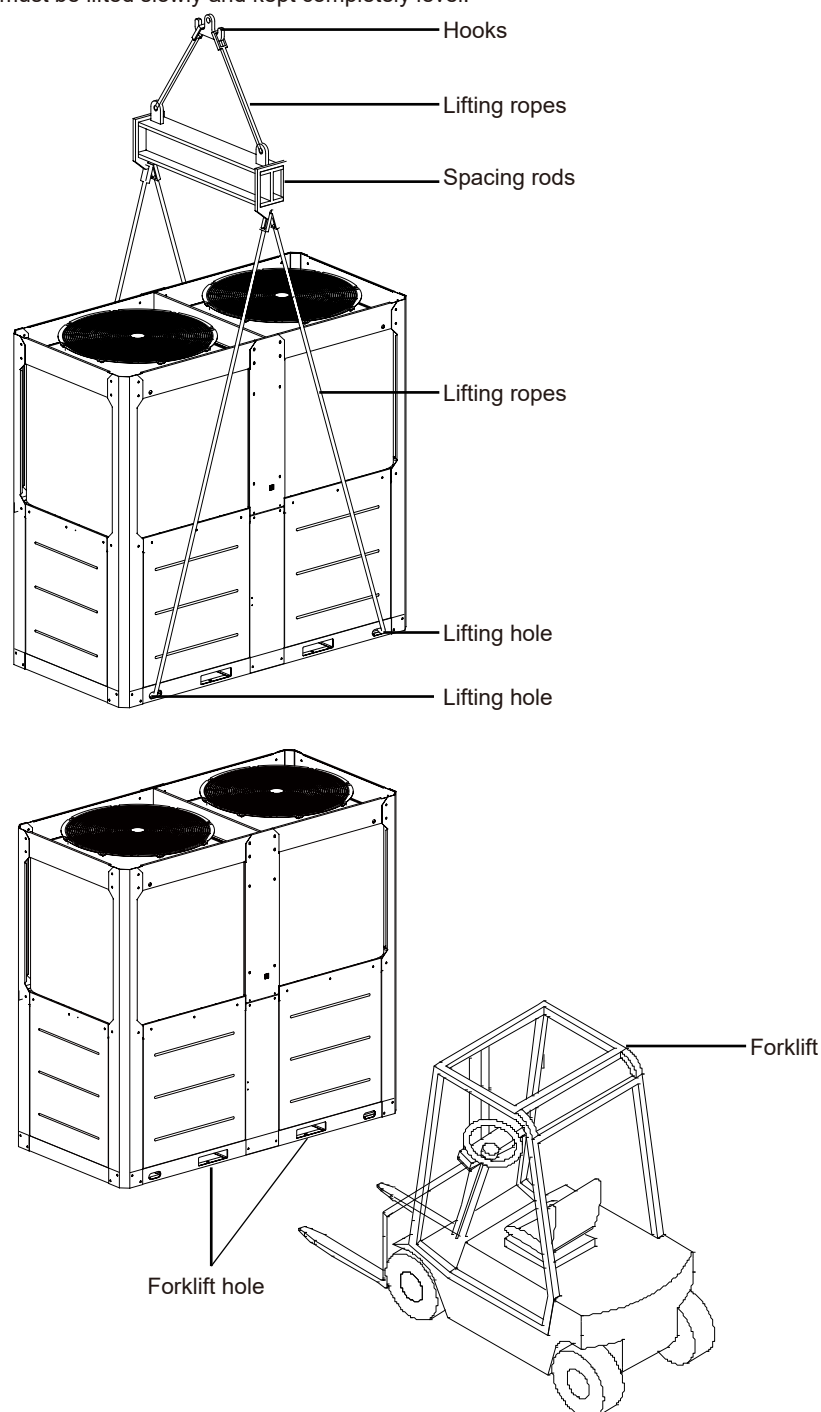

Fig. 4-2 Lifting and handling schematic diagram

4.4 Positioning and assembly

4.4.1 Foundation structure

All units are designed for outdoor installation. Whether it be installed on a balcony or on the ground, the installation area must be free of obstructions to avoid affecting the air flow of the finned heat exchanger.

The unit must be installed on a solid and completely level foundation; if the unit is installed on a balcony or roof, weight distribution beams may be required.

The foundation structure of outdoor unit shall be designed taking into account the following factors: 1) A solid foundation to prevent excessive vibration and noise.

The outdoor unit base shall be built on a solid ground or a structure with sufficient strength to support the weight of the outdoor unit. The base shall be at least 200 mm high and wider than the unit. For ground installation, a solid concrete foundation at least 250 mm thick and wider than the unit must be provided. The design of base height shall also take snow prevention into account.

Both steel and concrete foundations can be used.

A typical concrete foundation design is shown in the figure.

The typical concrete mix ratio is 1:2:4 (cement:sand:aggregate), reinforced with steel bars.

The edges of the base shall be chamfered.

To ensure that all contact points are equally safe, the base shall be completely level.

The foundation design shall ensure that the points where the unit contacts the foundation are fully supported.

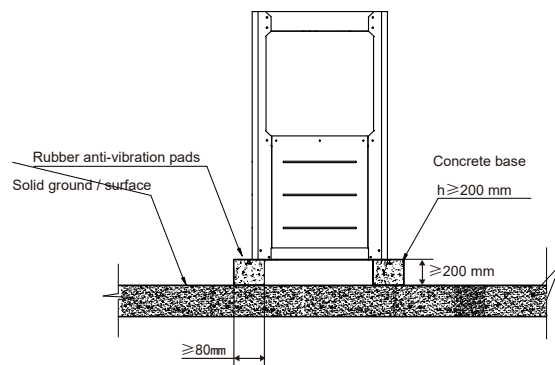

Fig.4-3 Front view of base structure

The unit must be installed on vibration absorber mount (AVM), which can be of rubber or spring type. The frame of the unit must be completely horizontal above the AVM.

The installation method shown in the figure must always be avoided. If the AVM is not adjustable, it is necessary to assure the flatness of the unit frame by using metal plate shims.

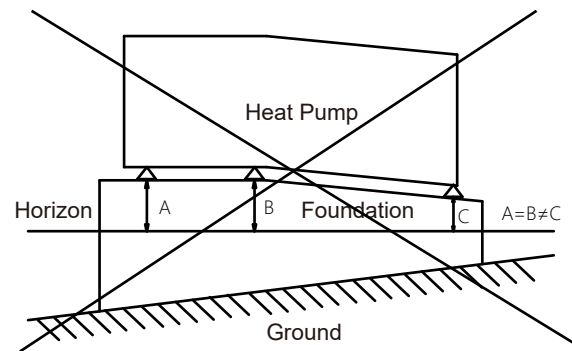

Fig.4-4

Before the unit is commissioned, the flatness must be verified by using a laser level or other similar equipment. For units with a length of no more than 7 m, the flatness shall not exceed 5 mm; for units longer than 7 m, the flatness shall not exceed 10 mm.

If the unit is installed in an area where it is easily accessible to people and animals, it is recommended to install protective nets for the condenser and compressor.

To assure the best performance at the installation site, the following precautionary measures and instructions must be followed:

Avoid air circulation and recirculation;

Make sure there are no obstacles blocking the air flow;

Ensure a solid foundation is provided to reduce noise and vibration;

Avoid installation in environments with excessive dust to reduce contamination of the fins;

The water in the system must be particularly clean, and all oil stains and rust stains must be removed. Mechanical water filters must be installed on the water inlet pipes of the unit;

Prevent the refrigerant from being discharged from the safety valve at the installation site. If necessary, the exhaust pipe can be connected, of which the cross-section and length must comply with national laws and European directives.

4.4.2 Foundation installation location

If the position of the unit is too high for maintenance personnel to carry out repairs conveniently, appropriate scaffolding shall be set up around the unit.

The scaffolding must be able to bear the weight of maintenance personnel and maintenance facilities.

The underframe of the unit shall not be embedded in the concrete of the installation foundation.

A drainage ditch shall be set up beneath the unit to drain off the possible condensate formed on the heat exchanger.

Drainage shall ensure that condensate water is kept away from roads and sidewalks, especially in climates where condensate water may freeze.

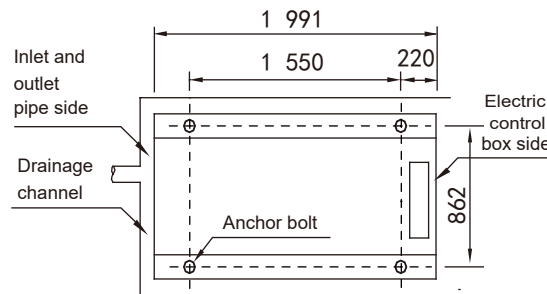

Fig. 4-5 Top view of schematic diagram of installation dimension of 50/60/70 kW

(unit: mm)

4.4.3 Installation of the unit damping devices

Damping devices must be installed between the unit and the foundation.

The unit is fixed on the foundation through the $\Phi 15$ mm diameter installation holes on the steel frame of the unit base by means of spring dampers. The center distance of the installation holes is as shown in the figure. The unit delivered doesn't come with the damper. Users shall select the damper according to relevant requirements. When the unit is installed on a high roof or in a vibration-sensitive area, please consult the relevant personnel before selecting the damper.

Installation of dampers

Step 1: Ensure that the flatness of the concrete foundation is within ± 3 mm, and then place the equipment on the pads.

Step 2: Raise the equipment to a height suitable for installing the shock absorber.

Step 3: Remove the clamping nut from the shock absorber. Place the equipment on the shock absorber and align the fixing bolt holes of the shock absorber with the fixing holes on the equipment base.

Step 4: Place the clamping nut of shock absorber back into the fixed hole of the equipment base and tighten it onto the shock absorber.

Step 5: Adjust the working height of the shock absorber base and tighten the leveling bolts. Tighten the bolt by one turn to ensure that the height adjustment differences of the shock absorber are consistent.

Step 6: Once the correct working height is reached, the locking bolts can be tightened.

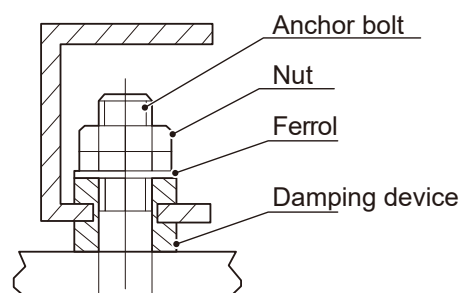
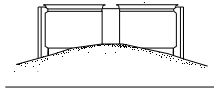

Fig. 4-6 Installation of the damper

4.4.4 Installation of wind and snow protection devices

For installations in areas with thick snow accumulation, wind and snow protection measures must be taken to assure the normal operation of the equipment. Otherwise, the accumulated snow may block the air flow, which could lead to the malfunction or even damage of the equipment.

(a) Buried in the snow



(b) Snow accumulated on the top plate

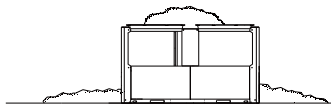

(c) Snow falling on the equipment

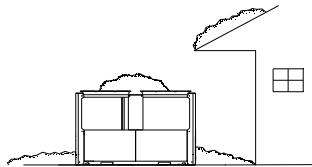

(d) Air inlet blocked by snow

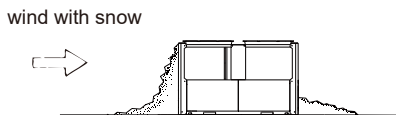

(e) Equipment covered with snow

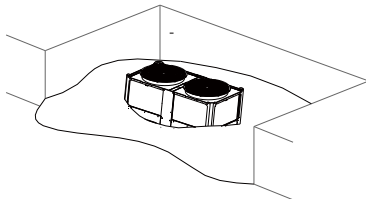

Fig. 4-7 Types of problems caused by snow

The base height shall be at least the same as the predicted snow depth in the local area to prevent problems caused by snow accumulation.

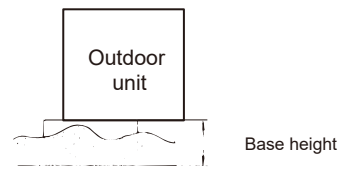

Fig. 4-8 Snow prevention base height

Thoroughly inspect the installation site. Do not install the equipment under awnings, trees or in areas where snow accumulates.

Precautions on designing snow covers:

To ensure sufficient air flow for the heat pump, when designing the protective cover, the dust-proof resistance shall be 1 mm water column or less than the allowable external static pressure of the unit.

The protective cover must be strong enough to withstand the weight of accumulated snow and the pressure caused by strong winds and typhoons.

The protective cover shall not affect air discharge and intake.

4.5 Minimum space requirements

All minimum spacings of the units must be observed to ensure the best ventilation of the condensers. When determining the location of the unit for proper air circulation, the following factors must be taken into account:

Avoid any gas backflow;

Avoid insufficient air supply to the finned heat exchanger.

Both of these situations may lead to an increase in condensing pressure, thereby reducing energy efficiency and capacity.

The units on either side must be favorable to post-installation maintenance, and the vertical air exhaust shall not be obstructed. The following figure shows the minimum space required.

Vertical air discharge shall not be obstructed.

When installing two units in a free space, the recommended minimum space is 1100 mm; when installing two units in a row, the minimum space is 800 mm. The following figure shows a recommended installation example.

If the recommended minimum space from the wall or vertical obstacles is not adhered to during the installation of the unit, it may result in insufficient air circulation or supply to the finned heat exchanger, thereby reducing the capacity and efficiency of the unit.

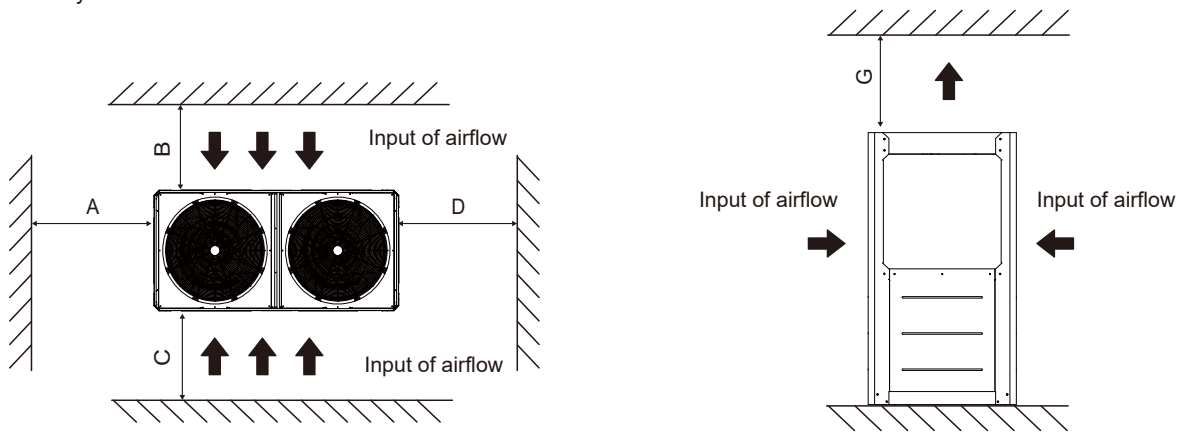

Fig. 4-9 single unit installation

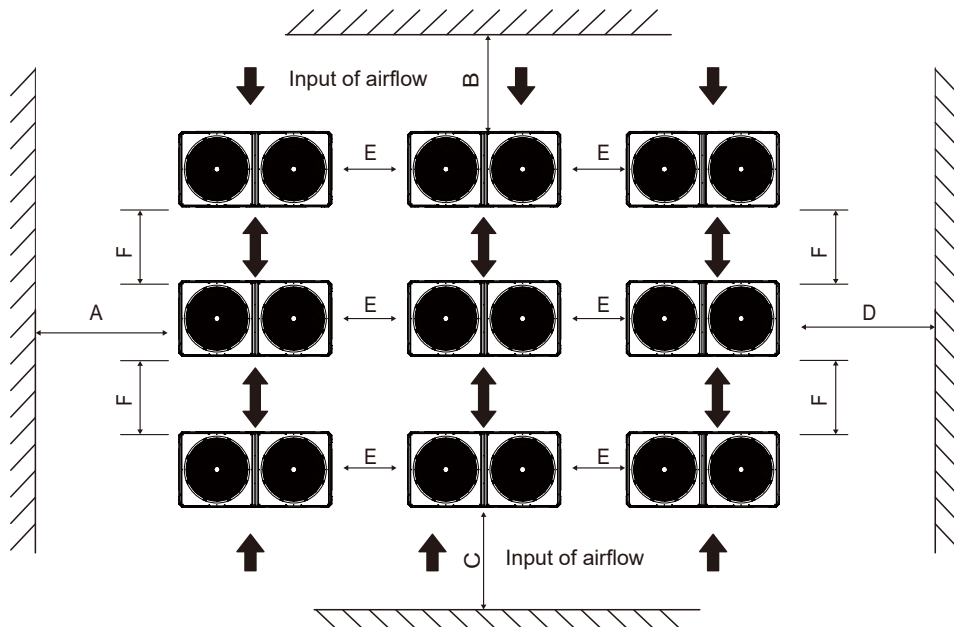

Fig. 4-10 multiple units installation

Table 4-1

Installation space (mm)			
A	≥1 500	E	≥800
B	≥1 500	F	≥1 100
C	≥1 500	G	≥3 000
D	≥1 500	/	/

To ensure sufficient air supply to the finned heat exchanger, the influence of the downdraft caused by surrounding high-rise buildings on the unit shall be taken into account when installing the unit.

If the unit is installed in a place with a high air flow rate, such as an exposed roof, measures such as sunken fences and louvers can be taken to prevent turbulent interference from entering the air of the unit.

If a sunken fence needs to be set up for the unit, the height of the rear one shall not exceed that of the front one.

If the unit needs to run in winter and the installation site may be covered with snow, the unit shall be placed at a position higher than the snow surface to assure smooth air flow through the coil.

WARNING

When more than 20 units are installed together, there may be cold island or heat island effect, please contact professionals to obtain proper installation method.

When using air source heat pumps for cooling or heating, the phenomenon where the local air temperature undergoes significant changes due to the evaporator or condenser of the heat pump absorbing or discharging heat from the surrounding air.

Specifically:

Cooling mode: In cooling mode, the condenser of the heat pump discharges heat into the surrounding air, causing an increase in local air temperature, creating a "heat island effect".

Heating mode: In heating mode, the condenser of heat pump absorbs heat from the surrounding air, causing a decrease in local air temperature, creating a "cold island effect".

This phenomenon may have an impact on the surrounding environment, especially in areas where air source heat pumps are densely installed. The cold island effect may lead to a local temperature decrease, affecting plant growth, building energy consumption or human comfort.

4.6 Sound and voice protection

The main noise of the unit is generated by the rotation of the compressor and the fan.

The noise level of each model is listed in the manual or the annex.

If the unit is installed, operated and maintained properly, the noise level does not require any special protective devices for continuous operation nearby without any risk.

If special sound requirements need to be met, additional noise attenuation devices may be required. The unit must be isolated from its base with extreme care, and the vibration damping elements (provided as an option) must be correctly applied. Flexible joints shall also be installed at the water pipe connections.

The additional sound insulation measures shall not affect the air intake volume of the unit and shall not increase the air outlet resistance of the unit.

4.7 Water circuit connection of the unit

4.7.1 Water pipes

Pipes shall be designed to minimize the use of elbows and changes in the vertical direction. This may significantly reduce installation costs and improve system performance.

Pipeline installation must comply with the requirements of local pipeline regulations.

The water system must have:

- 1) Vibration isolation installation to reduce the transmission of vibration to the structure.
- 2) Isolation valves to isolate the unit from the water system during maintenance.
- 3) To protect the unit, a water flow switch must be installed to ensure water flow in the plate heat exchanger and prevent the BPHE from freezing.
- 4) Manual or automatic venting devices shall be installed at the highest point of the system, and drainage devices shall be installed at the lowest point of the system.
- 5) Plate heat exchangers and heat recovery devices shall not be located at the highest point of the system.
- 6) Suitable devices (e.g. expansion tanks) that can maintain the pressure of the water system shall be installed.
- 7) Filters that can remove particles from fluids shall be installed. The use of filters may extend the service life of plate heat exchangers and pumps, and help maintain the good condition of the water system. The water filter must be installed closest to the unit. If the water filter is installed in other parts of the water system, the installer must ensure that the water pipes between the water filter and the plate heat exchanger are clean. Filters having no less than 50 meshes per inch shall be provided.
- 8) In winter, if the unit is idle for a long time, the water must be drained, unless an appropriate proportion of ethylene glycol mixture is added to the water circuit as antifreeze protection.
- 9) When replacing the unit, the entire water system must be drained and cleaned before installing the new unit. It is recommended that water be regularly tested and properly treated chemically before starting up new units.
- 10) If ethylene glycol is added to the water system as an antifreeze protection, please note that the suction pressure will decrease, the performance of the unit will decline, and the water pressure drop will be greater. The protection systems of the unit, such as anti-freezing and low-pressure protection, all need to be readjusted.
- 11) Before insulating the water pipes, check for any leaks. The entire hydraulic circuit must be insulated to prevent condensation and a decline in cooling capacity. In winter, it is necessary to protect water pipes from frost (for example, by using antifreeze or heating cables).
- 12) A safety valve shall be installed on the water pipe downstream of the plate heat exchanger to ensure that the water pressure does not exceed the design pressure of the water-side heat exchanger.
- 13) Before the unit is put into operation, all water pipes shall be thoroughly flushed to ensure no residue of any debris. No debris shall be flushed into or discharged from the heat exchanger.

- 14) Water must enter the heat exchanger through the inlet; otherwise, the performance of the unit will decline.
- 15) Pipes and their interfaces must be independently supported, but shall not be supported on the equipment body.
- 16) Pipes and interfaces of the plate heat exchanger shall be easy to remove for operation, cleaning and inspection of the interfaces and pipes.
- 17) A bypass pipe and bypass valve shall be installed for the plate heat exchanger to clean the external system of the water passage before adjusting the equipment. During maintenance, the water channels of the heat exchanger can be cut off without disturbing other heat exchangers.
- 18) Flexible joints shall be used between the interfaces of the heat exchanger and the on-site pipelines to reduce the transmission of vibration to the building.
- 19) For ease of maintenance, the total inlet and outlet pipes of the unit shall be equipped with thermometers or pressure gauges. These instruments need to be purchased by the users themselves.
- 20) All the low-lying parts of the water system shall be equipped with drain valves to ensure that the water in the heat exchanger and the entire system can be drained completely, and all the high-lying parts shall be fitted with air release valves to facilitate the discharge of air in the pipes. The exhaust valve and drain shall not be insulated to facilitate maintenance.
- 21) All the water pipes in the system shall be in an insulated state.
- 22) The outdoor water pipes shall be wrapped with auxiliary heating tapes for insulation. The auxiliary heating tapes shall be made of PE, EDPM, etc., with a thickness of 20 mm, to prevent the pipes from freezing and cracking in low temperatures. The power supply of the heating tape shall be equipped with an independent fuse.
- 23) A water temperature sensor shall be installed at the common outlet of the parallel units.
- 24) For water supply networks that include filters and heat exchangers, sediment or fouling may seriously damage the heat exchangers and water pipes. The installer or user must assure the quality of the water and prevent any substances other than de-icing salt mixtures and air from entering the water system, as they may oxidize and corrode the metal parts inside the heat exchanger.
- 25) When the environment temperature is below 2 °C and the equipment is not in use for a long time, the water inside the equipment shall be drained. If the equipment is not drained in winter, its power supply shall not be cut off, and the fan coil units in the water system must be equipped with three-way valves to assure smooth circulation of the water system when the anti-freezing pump is started in winter.

4.7.2 Water pipe connection

The unit is equipped with interfaces for connecting the heat pump to the water circuit of the system. The operation must be carried out by authorized technical personnel and all current relevant national regulations must be observed.

The installation and connection methods of the inlet and outlet pipes are as shown in the following diagrams. The unit is clamped. The specifications and parameters of the water pipes and threads are detailed in the table below.

Table 4-2

Model	Pipe connection methods	Specifications of water pipe
50/60/70 kW	Clamp connection	DN 50

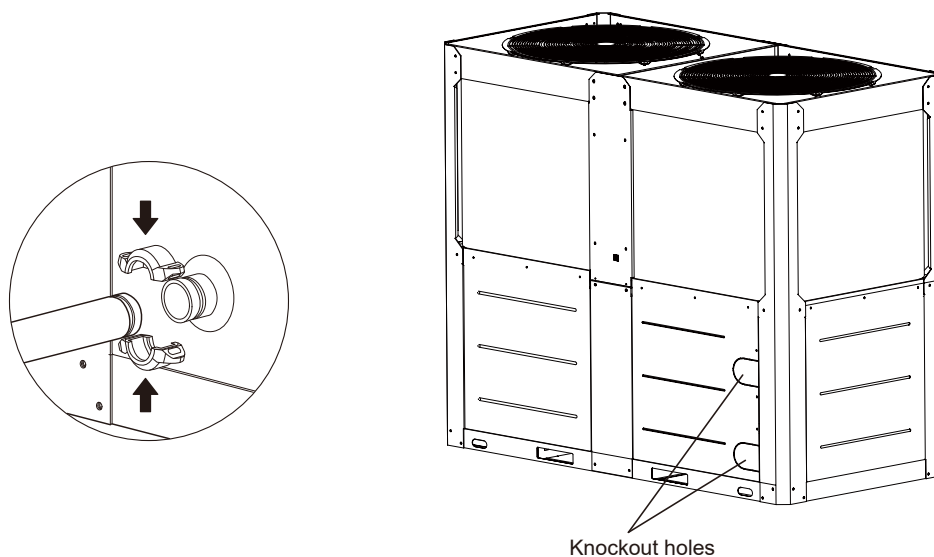

Fig. 4-11 Water pipe connection diagram

NOTE

Knockout holes are designed at the corresponding inlet and outlet positions on the panel. Before connecting the water pipes, the sheet metal here needs to be knocked out.

Drainage layout

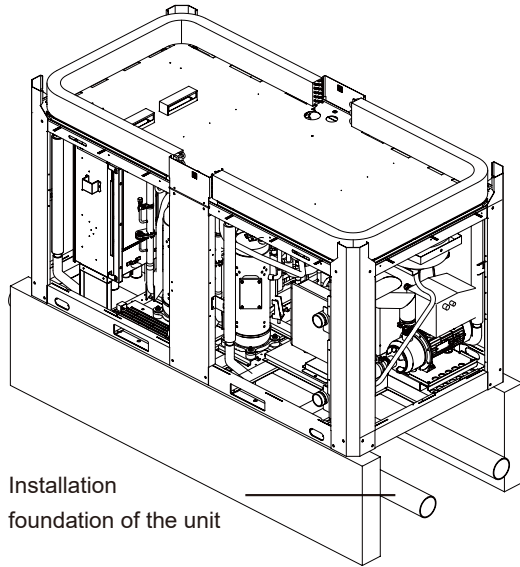

Fig. 4-12

Diagram of Centralized Drainage Structure

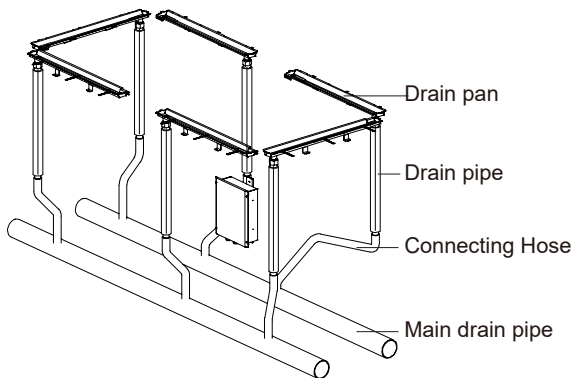

Fig. 4-13

Instructions for connecting the centralized drainage pipe:

1. The water collection tray and drain pipe are used to collect condensate water and are already configured inside the unit.
2. The installation reference for the unit is designed and installed by the customer themselves. It can be based on a cement foundation or a metal steel frame foundation.
3. The main drain pipe is used to collect the condensate water from the unit and discharge it into the floor drain. It needs to be purchased and installed by the customer. It is recommended to use plastic drainage pipes with a diameter larger than 80 mm, and the quantity of one or two.
4. The function of the connecting hose is to link the drain pipe inside the unit with the main drain pipe. It needs to be purchased and installed by the customer. It is recommended to use a flexible drainage pipe, which is convenient for connection and has an inner diameter greater than 32 mm.

Installation on a soft ground

Draining condensate into a gravel bed

For installation on a ground, the condensate must be discharged through a downpipe into a gravel bed that is located in a frost-free area.

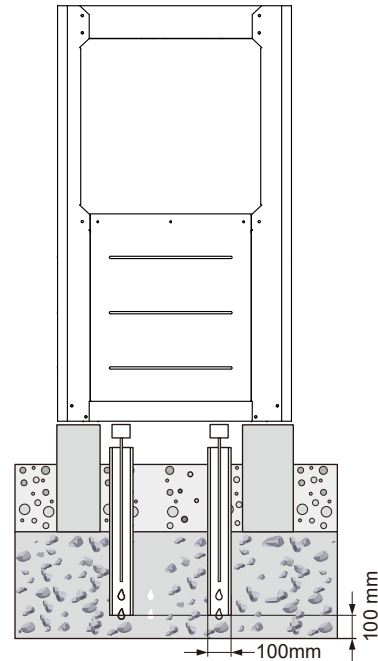

Fig. 4-14

The downpipe must flow into a sufficiently large gravel bed so that the condensate can trickle away freely.

NOTE

To prevent the condensate from freezing, the heating wire must be threaded into the downpipe through the condensate discharge.

Draining condensate through a pump sump/soakaway

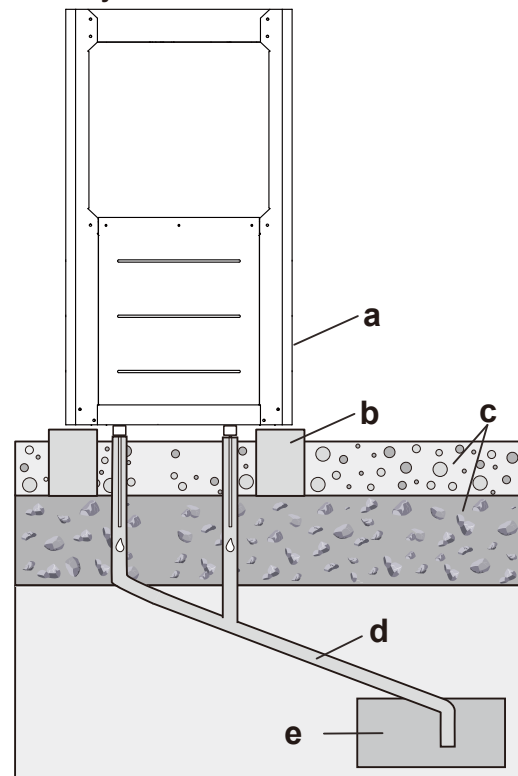

Fig. 4-15

- a - Outdoor unit
- b - Concrete strip foundations
- c - Foundation (See 5.3.1 Installation on a ground)
- d - Drain pipe(at least DN 40)
- e - Pump sump/soakaway

Draining condensate through sewer

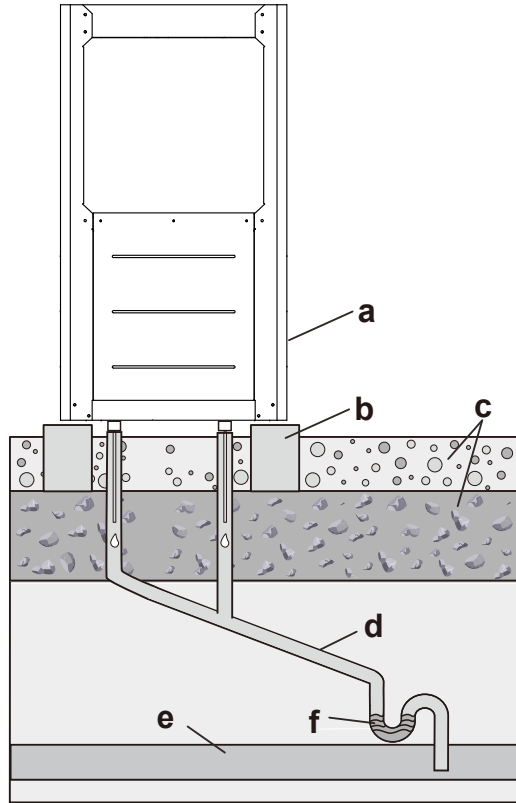

Fig. 4-16

- a - Outdoor unit
- b - Concrete strip foundations
- c - Foundation (See 5.3.1 Installation on a ground)
- d - Drain pipe (at least DN 40)
- e - Sewer
- f - Stench trap in an area free from frosting risks

Installation on a solid ground

Guide the condensation pipe to a sewer, pump sump or soakaway.

The drain plug in the accessory pack cannot bend to another direction. For this, use a hose to guide the condensate into a sewer, pump sump or soakaway through a gully, balcony run-off or roof run-off.

Open gullies within the safety zone do not pose any safety risk.

Installation on a flat roof

Refer to Installation on a solid ground.

NOTE

For all installation types, ensure that any accumulated condensate is discharged in a frost-free manner.

To prevent the condensate from freezing, the heating tape can be threaded into the downpipe through the condensate discharge.

4.7.3 Y-type filter

A Y-type filter must be installed.

Y-type filters are used to filter debris and particles in water, ensuring the correct operation of water flow switches and protecting equipment such as heat exchangers, water pumps, valves, and water meters from damage.

WARNING

Failure to install a Y-type filter or incorrect installation may cause damage to the heat exchanger, leading to refrigerant leakage and serious consequences.

1) Selection of Y-type filters

Y-type filter shall comply with national standards. Mesh count: 50.

Nominal pressure: 1.6 MPa.

Flow rate and water resistance: According to the technical parameters provided by the Y-type filter manufacturer, the water resistance is included in the pump selection calculation.

2) Installation precautions for Y-type filters:

Make sure that the operating pressure is within the specified range to avoid excessive pressure causing damage to the Y-type filter.

Before installation, the interior of the Y-type filter must be cleaned thoroughly to assure unobstructed flow and effective filtration.

3) Installation location

It must be installed at the inlet of the water pipe to facilitate the filtration of debris in the water.

The installation location must avoid being impacted by external forces.

NOTE

Regular cleaning

When cleaning or replacing the Y-type filter, first close the valves on both sides of the Y-type filter, depressurize and then start cleaning. Empty the debris and clean the mesh filter or replace the mesh filter. When replacing the mesh filter, it is necessary to select a mesh filter of the same specification and model as the Y-type filter to assure the filtering effect and smoothness.

NOTE

The following listed components don't come with the unit but can be provided upon request. Additionally, their installation is mandatory.

Problems may arise if contaminants enter the water circuit. Therefore, when connecting water circuits, please keep the following points in mind:

1. Only use internally clean pipes.
2. When removing burrs, keep the pipe end facing down.
3. When passing pipes through walls, cover the pipe ends to prevent dust and dirt from entering.
4. Before connecting the pipes in the system to the unit, clean the pipes located between the filter and the unit with running water.

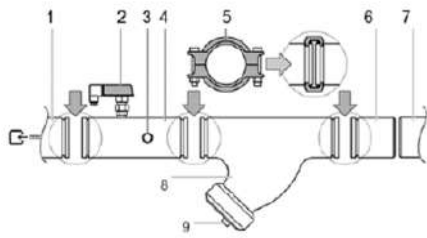

1. Water inlet
2. Flow switch
3. Inlet water temperature sensor
4. Inlet pipe with flow switch and inlet water temperature sensor
5. Joint
6. Reverse pipe
7. On-site water pipeline loop
8. Filter
9. Filter and cup

The water in the system must be particularly clean, and all oil stains and rust stains must be removed. Install a mechanical filter at the inlet of each heat exchanger. Failure to install the mechanical filter may allow solid particles and/or welding spatter to enter the heat exchanger. We recommend installing a filter with a mesh aperture no larger than 1.1 mm.

If a mechanical filter is not installed, the manufacturer will not be responsible for any damage to the heat exchanger.

4.7.4 System water flow rate

To ensure sufficient water flow through the plate heat exchanger, a flow switch must be installed on the water line. The flow switch is designed to stop the operation of the unit when the water flow is interrupted, thereby preventing the plate heat exchanger from freezing.

The maximum and minimum water flow rates of the unit are shown in the following table.

Table 4-3

Model	Item	Waterflow rate(m ³ /h)	
		Minimum	Maximum
50 kW	Normal Temperature Outlet(S1-2=OFF)	9.6	14.4
	High Temperature Outlet(S1-2=ON)	1.8	10.3
60 kW	Normal Temperature Outlet(S1-2=OFF)	9.6	14.4
	High Temperature Outlet(S1-2=ON)	1.8	12.4
70 kW	Normal Temperature Outlet(S1-2=OFF)	9.6	14.4
	High Temperature Outlet(S1-2=ON)	1.8	14.4

4.7.5 Selection of water tanks

1) Functions of the buffer water tank

The buffer water tank helps prevent frequent equipment startups and shutdowns, thereby protecting the equipment and extending its service life. During the defrosting process, the buffer water tank can also ensure the stability of the system and the comfort of the user.

2) Selection of buffer water tanks

Two methods, namely the design calculation and the empirical estimation, are provided for the selection of buffer water tanks.

① Design calculation

a. Defrosting calculation in heating mode

During the defrosting process of the air source heat pump heating system, the supply water temperature will drop. The volume of the buffer water tank is calculated to ensure that the defrosting time of the unit reaches 4 minutes and the water supply temperature drop before and after defrosting does not exceed 3 °C.

Calculation of the minimum effective water capacity in heating mode:

$$MH = [Qh * Hmin * TH / (C * \Delta TH)] / \rho$$

Where,

MH: Minimum water capacity of the system, m³;

Qh: Rated heat output of the main unit, kW;

Hmin: Defrosting capacity coefficient, %; usually taken as 50%;

ΔTH - Temperature drop of water supply before and after defrosting, °C; taken as 3°C;

C: Specific heat of water, taken as 4.18 kJ/(kg·°C).

ρ : Density of water, 1000 kg/m³;

TH: Defrosting time, S; taken as 240S;

b. Calculation in cooling mode

In cooling mode, to prevent frequent machine startup and shutdown, it is necessary to ensure at least enough water to keep the equipment running for 5 minutes.

Calculation of minimum effective water capacity in cooling mode:

$$MC = [Qc * CA * Cmin * TC / (C * \Delta TC)] / \rho$$

Where,

MC: Minimum water capacity of the system, m³;

Qc: Rated cooling capacity, kW;

CA - Capacity coefficient under low-load conditions: generally taken as 1.6.

Cmin: The minimum operating capacity ratio of the unit, %; 100% for fixed-frequency units and 30% for variable-frequency units;

ΔTC : Temperature control range, °C; default 4°C;

C: Specific heat of water, taken as 4.18 kJ/(kg·°C);

ρ : Density of water, 1000 kg/m³;

Tc - Running time in the cooling mode, S, generally taken as 300S;

c. Figure out the system capacity based on the cooling and heating conditions and take the larger value;

$$M = \text{MAX}(MH, Mc)$$

For single-cooling units, take Mc; for single-heating units, take MH;

d. The effective water capacity of the system refers to the total capacity of the water system during running, including the main pipelines involved in the circulation, water storage tanks, the constantly open ends of two-way valves, etc. Effective water capacity of water system pipelines:

$$M2 = V * L$$

Where, M2: Effective water capacity of the water system, m³;

L: Total length of the system pipeline, m;

V: Water capacity per meter of pipe length for each model system pipeline, m³/m.

e. The volume of the buffer water tank refers to the minimum water capacity required to ensure the normal operation of the unit.

$$V_{\min} = M - M_2$$

V_{\min} —Minimum volume of the buffer water tank, m^3 .

② Empirical estimation

When the water capacity of the system cannot be estimated, the volume of the buffer water tank may be estimated based on experience:

$$V_{\min} = Q \cdot K$$

Where, V_{\min} : Minimum volume of the buffer water tank, L;

K: Capacity volume estimation coefficient, L/kW; for comfort air conditioning, take 10; for process air conditioning, take 15;

Q: Main unit heat output, kW.

3) Precautions for selecting buffer water tanks:

The configuration of the buffer water tank is also related to the specific installation conditions of the works and the form of the terminal. If the water capacity of the system itself is large or the terminal is in the form of floor heating, a buffer water tank may not be added. The installation of a buffer water tank is only beneficial to the running of the system. It is recommended to make a comprehensive consideration based on the specific site conditions and costs.

The results from the above two methods are different. Method 1 is more accurate, while Method 2 is an empirical estimation. It is recommended to calculate as per Method 1.

When multiple units are connected in parallel, the unit with the largest capacity among the parallel units shall be selected as the reference unit for the computer.

WARNING

Sufficient system water volume is a necessary condition for the reliable running of machine; otherwise, it may cause frequent startup and shutdown, shorten its service life, and result in large fluctuations in water temperature during defrosting, leading to abnormal defrosting.

When the water volume in the system is insufficient, a buffer water tank must be added to the system to meet the minimum water volume requirement for running.

4.7.6 Selection and installation of pumps

1) Requirements for pump selection

The external interlocked water pump must be controlled by the main unit logic program, and the signal shall be interlocked with the external water pump control cabinet.

The water pump shall be installed on the inlet pipe of the unit, and the inlet and outlet pipe diameters of the water pump shall be the same as the main water pipe diameter.

The inlet and outlet interfaces of the water pump shall be connected flexibly, and the foundation shall have vibration damping measures.

The water pump shall be installed outdoors and have measures to prevent rain, sun exposure and freezing.

The selected pump power shall meet the required flow/head performance curve at any point and ensure no humps or inflection points within the working range.

At least one spare pump shall be set up to ensure that the water system can remain running during the maintenance and replacement of pumps. The standby pump is of the same type as the main pump.

When the head of the pump fails to meet the water pressure requirements at the most unfavorable point, the head can be increased by using a series of pumps while keeping the flow rate unchanged.

When the flow rate of a single pump fails to meet the flow rate requirement at the most unfavorable point, parallel pumps can be used. Under the condition of keeping the outlet pressure of the pump unchanged, the flow rate of the entire system can be increased.

2) Pump selection and calculation

① Flow selection calculation:

For a primary pump system, the rated flow of the water pump shall be equal to or greater than the rated flow of the unit. When multiple units are connected in parallel, the rated flow of the pump shall be equal to or greater than the sum of the rated flows of the parallel units.

The secondary pump system requires that the flow rate (L1) of the circulating pump on the main unit side be equal to or greater than the rated flow rate of the unit. The flow rate of the circulating pump at the end-user side (L2) can be calculated using the following formula:

$$L_2 = (1.1-1.2) \cdot (Q \cdot 0.86 / \Delta T)$$

Where,

L2 - Circulating water flow rate m^3/h ;

Q - Terminal total load, kW;

ΔT - Supply and return water temperature difference at the terminal, $^{\circ}C$

② Head selection and calculation

Calculation of head for primary pump system:

H1: H2

$$\text{Main unit side: } H_1 = (h_{11} + h_{12}) \cdot (1.1-1.2)$$

$$\text{Terminal side: } H_2 = (h_{21} + h_{22}) \cdot (1.1-1.2)$$

Where,

h_{11} —Main unit-side water resistance, m;

h_{12} —Most unfavorable pipeline resistance on the main unit side, including the sum of water pipe resistance and various valve body resistance, m;

H_{21} —End water resistance, m;

h_{22} —Most unfavorable pipeline resistance at the end, including the sum of the resistance of the water pipe and various valve bodies, m

The calculation method of the head of the secondary pump system shall take into account the head of the primary pump, the water resistance of the unit and the pipeline of the circulating water pump on the main unit side H1, the height difference between the water tank and the main unit, and the open water system.

It is recommended that the total head value be no less than 18 m.

For open systems, when calculating the head H2 of the circulating water pump on the user side, the height difference between the water tank and the main unit must be taken into account. This head is restricted by the water resistance at the end and the water resistance of the most unfavorable loop.

4.7.7 Water quality requirements

Before putting the unit into operation, the clean water circuit shall be flushed. Debris released during the flushing process shall not enter the plate heat exchanger. It is advisable to install a bypass pipe and valve of appropriate size to facilitate the flushing of the pipeline system. A bypass pipe can be used during maintenance to isolate the plate heat exchanger without interrupting the water flow of other units.

Any damage caused by foreign objects or debris inside the plate heat exchanger is not covered by the warranty. Fouling, scale, corrosion fragments and other substances may accumulate inside the heat exchanger, reducing its heat exchange capacity. The pressure drop may also increase, thereby reducing the water flow.

Proper water treatment may reduce the risks of corrosion, erosion, scaling, etc. The most appropriate water treatment method shall be determined based on the type of system and local water quality.

The manufacturer shall not be held responsible for machine damage or malfunction caused by untreated or improperly treated water.

Table 4-4

test item	units	permissible value	test item	units	permissible value
pH(25℃)	/	7.5~8.0	Dissolved Oxygen	mg/L	not detectable
turbidity	NTU	≤3	turbidity	mg/L	not detectable
Conductivity(25℃)	μS/cm	≤200	Organophosphorus (P)	mg/L	≤50
Chloride ion	mg/L	≤50	Sulfide ion	mg/L	≤50
Iron content	mg/L	≤0.3	acid consumption	mg/L	not detectable
calcium hardness	mg/L	≤80	Sulfide ion	mg/L	not detectable
total alkalinity	mg/L	≤200	Ammonium ion	mg/L	not detectable
			silicon dioxide	mg/L	≤30

⚠ WARNING

Water quality is crucial for the normal and reliable running of the unit. If water quality fails to meet the requirements, it may damage the unit and reduce its service life. It is essential to ensure that the water quality is qualified.

4.7.8 Selection of pipe diameters

The total inlet and outlet water pipes can be selected by referring to the following table (not the inlet and outlet water pipes of the unit). This value is for reference only. Please select according to the actual project situation in the end.

Table 4-5

Rated capacity (kW)	Total inlet and outlet diameter	Rated capacity (kW)	Total inlet and outlet diameter
25≤Q≤40	DN32	210<Q≤325	DN100
40<Q≤50	DN40	325<Q≤510	DN125
50<Q≤80	DN50	510<Q≤740	DN150
80<Q≤145	DN65	740<Q≤1 300	DN200
145<Q≤210	DN80	1300<Q≤2 080	DN250

4.7.9 Single pump or multiple pump installation

1) DIP switch selection

When all units controlled by the same wired controller share a main water pump, the S1-3 DIP switch shall be set to OFF (the ex-factory default setting); if each unit controlled by the same line controller is equipped with an independent water pump, then this DIP switch shall be set to ON.

NOTE

If the DIP switch settings are inconsistent, a fault FP will be reported, causing the equipment to fail to run.

When only one water pump is installed, only the main unit has the water pump output signal, while the slave unit does not. When multiple pumps are installed, the pump control signals of both the master and slave pumps are valid.

2) Installation of the water pipe system

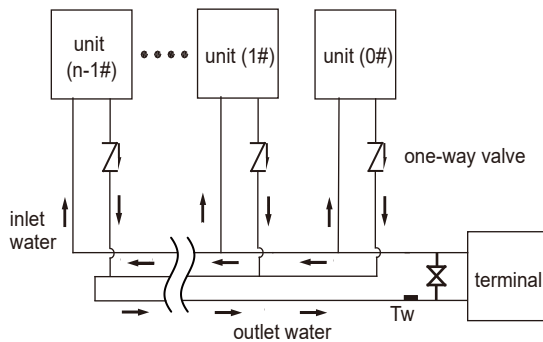

Fig.4-17

③ Electrical wiring

When a single water pump is installed, only the main unit needs to be wired, while the auxiliary unit does not require wiring. When multiple water pumps are installed, both the master pump and the slave pumps need to be wired. For the specific wiring details, please refer to Figures 6-10 and 6-11.

NOTE

When multiple equipment are installed in parallel, please pay attention to the following matters: Each unit corresponds to an address code which cannot be duplicated.

The main outlet water temperature sensor, target flow controller and auxiliary electric heater are only controlled by the main unit.

Only one wired controller connected to the main unit is needed.

Only after all the addresses have been set and the above matters have been confirmed can the equipment be started through the wired controller. The maximum control distance of the wired controller is 500 m.

4.7.10 Expansion tank design

Expansion tanks are divided into open and closed types, with the function to maintain pressure and accommodate expanded water.

The open expansion tank is connected to the atmosphere and is not pressurized, generally installed at the suction inlet of the circulating water pump, 1 to 2 m higher than the highest point of the system. At this point, the water replenishment of the tank is based on water level replenishment. It is often used in large-scale systems. If a buffer water tank or a hot water storage tank is installed in an open water system, there is no need to design an expansion tank. When a primary water system is not equipped with a buffer water tank, an expansion tank shall be set up, and placed at the highest point of the water system.

The closed expansion tank is not connected to the atmosphere and can withstand pressure. It is installed at the suction inlet of the circulating water pump. If the machine room is far away, there is no need to connect the expansion tank to the machine room. Instead, the expansion tank is connected to the outdoor water return main pipe. Closed expansion tanks use constant pressure make-up water and are often used in small-scale systems.

Selection of the capacity of the expansion tank:

$$V = \text{System water capacity} * \text{Expansion coefficient} * \text{Safety margin}$$

Where, the expansion coefficient is set at 1% to 3%, and the safety margin is taken as 1.1 to 1.2.

4.7.11 Selection of auxiliary electric heaters

1) Use of auxiliary electric heaters

When certain system components are under maintenance or encounter temporary malfunctions, the auxiliary electric heater is turned on as a backup; the auxiliary electric heater ensures that the water temperature in the system can be maintained even under extremely low environment temperatures, compensating for the decline in the heating capacity of the unit under such conditions.

2) Interlocked control of auxiliary electric heaters

When the environment temperature is too low for the unit to start up or it fails to start due to fault protection, the auxiliary electric heater will automatically turn on according to the water temperature control program to ensure reliable running of the unit and the user's water supply. The selection of auxiliary electric heaters is shown as below. When the design point and the balance point are the same, the heating capacity of the unit will be equal to the heat load of the building. In this case, the auxiliary electric heater is not needed.

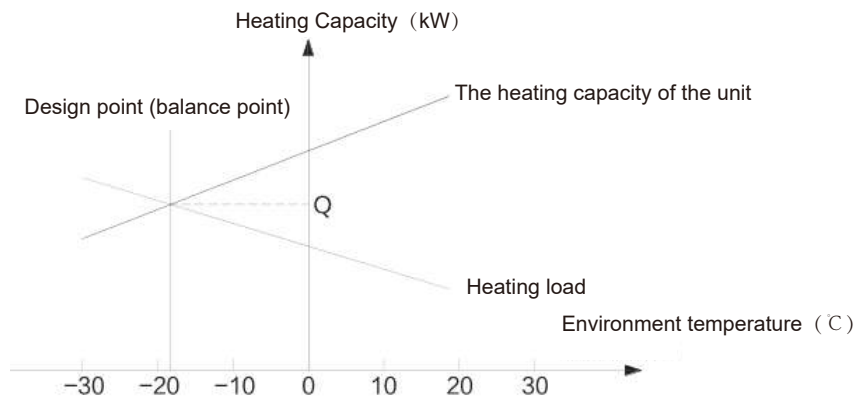

Fig. 4-18

If the design point does not coincide with the balance point, the heating capacity of the unit at the design point (Q_2) is less than the building's heat load (Q_1). In this case, the power of the electric heater must be able to make up for the difference between Q_1 and Q_2 .

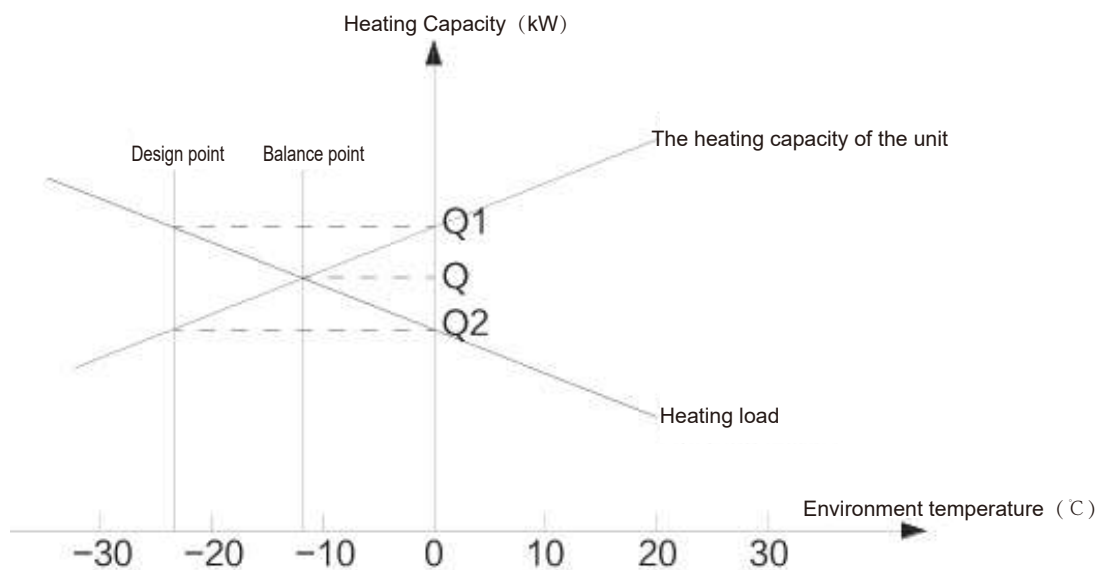
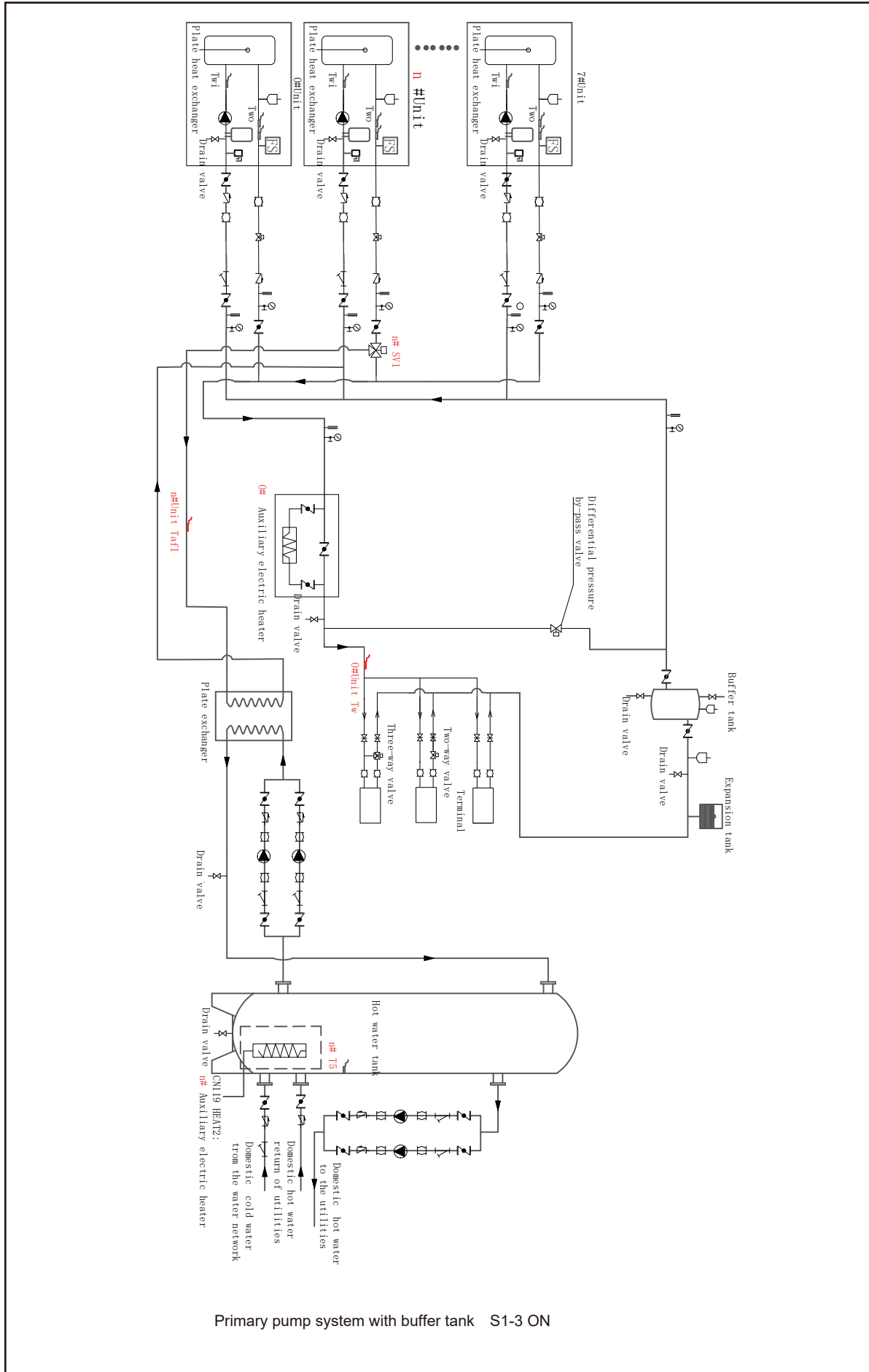
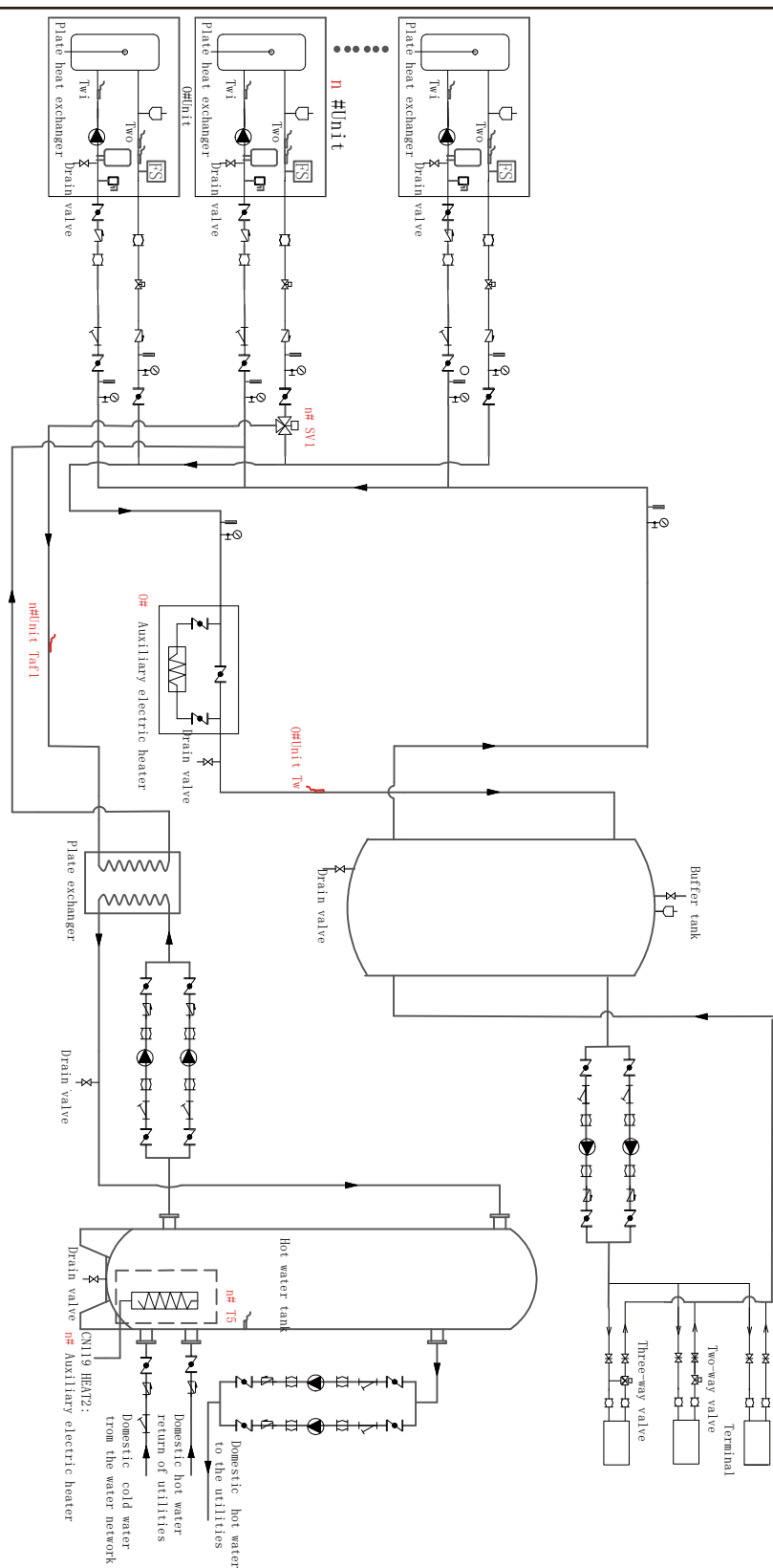

Fig. 4-19

4.7.12 Water system diagram





Secondary pump system with buffer tank S1-3 ON

Water flow switch	Gate valve	Safety valve	Drain valve	Auto vent valve
Soft joint	Water pump	Shut off valve	Temperature sensor	Solenoid three-way valve
Water pressure meter	Check valve	Thermometer	Y-type strainer	Expansion vessel

Fig.4-20 Connection drawing of water system

NOTE

The proportion of two-way valves on the terminals shall not exceed 50%.

The outlet water temperature sensor (Tw) for the main unit at address 0 shall be installed on the main outlet water pipe.

The control switch for the unit's hot water tank and hot water exchange pump is located on the 0# unit slave board at port CN125 (220v), and the pump output is controlled through port CN108 (0-10v).

NOTE

To prevent back siphoning, a check valve shall be installed at the inlet of the domestic hot water tank or water line in accordance with local laws.

4.7.13 Capacity correction

Table 4-6 Plate Heat Exchangers- Fouling Coefficients

A	B	C	D
0.0176	1.000	1.000	1.000
0.0440	0.978	0.986	0.992
0.0880	0.957	0.974	0.983
0.1320	0.938	0.962	0.975

Legend:

A = Fouling coefficient (m²· C /kW)

B = Cooling capacity correction coefficient

C = Absorption power correction coefficient

D = Energy efficiency ratio correction coefficient

Table 4-7 Air Heat Exchanger - Altitude Correction

	0	300	600	900	1200	1500	1800
A	1013	977	942	908	875	843	812
B	1.000	0.993	0.986	0.979	0.973	0.967	0.960
C	1.000	1.005	1.009	1.015	1.021	1.026	1.031

Legend:

A = Altitude (m)

B = Atmospheric pressure (mbar)

C = Cooling capacity correction coefficient

D = Absorption power correction coefficient

- The maximum operating altitude is 2,000 m above sea level.

- If the unit is installed in an area with an altitude of 1000 to 2000 m, please contact the factory.

Table 4-8 Minimum Antifreeze Percentage in Low-Temperature Air Environment

AAT (2)	-3	-8	-15	-20
A(1)	10%	20%	30%	40%
AAT (2)	-3	-7	-12	-70
B(l)	10%	20%	30%	40%

Legend:

AAT = Ambient air temperature (°C) (2)

A = Ethylene glycol (%) (1)

B = Propylene glycol (%) (1)

(1) The minimum percentage of antifreeze required to prevent water circuits from freezing at the specified ambient air temperature.

(2) Ambient air temperature overrunning the running limits of the unit.

Even when the unit is not running, the water circuit needs to be protected in winter.

According to the expected minimum environment temperature, it shall be ensured that the concentration of the ethylene glycol solution in the water system complies with the values specified in the following table. After adding ethylene glycol, the freezing point of the water will decrease, and it will cause the performance of the unit to deteriorate. The system needs to make corrections to the unit capacity, water flow rate and pipeline pressure drop. The relevant correction coefficients are detailed in the data mentioned in the following table.

Table 4-9 Ethylene Glycol(Toxic)

Concentration of ethylene glycol(%)	Modification coefficient				Minimum outdoor temperature(°C)
	Cooling capacity modification	Power input modification	Water resistance	Water flow modification	
0	1 000	1 000	1 000	1 000	0
10	0.984	0.998	1.118	1.019	-5
20	0.973	0.995	1.268	1.051	-15
30	0.965	0.992	1.482	1.092	-25

Table 4-10 Propylene Glycol(Low Toxic;Inclnding the necessary, classified as Category III according to EN1717)

Concentration of ethylene glycol(%)	Modification coefficient				Minimum outdoor temperature(°C)
	Cooling capacity modification	Power input modification	Water resistance	Water flow modification	
0	1 000	1 000	1 000	1 000	0
10	0.976	0.996	1.071	1 000	-4
20	0.961	0.992	1.189	1.016	-12
30	0.948	0.988	1.380	1.034	-20

4.7.14 Operating range

The standard voltage of the power supply is 380 - 415 V 3N-50 Hz, the minimum allowable voltage is 342 V, and the maximum voltage is 456 V.

The unit shall be used and operated under the following outdoor temperature conditions.

**50/60/70 kW
COOLING**

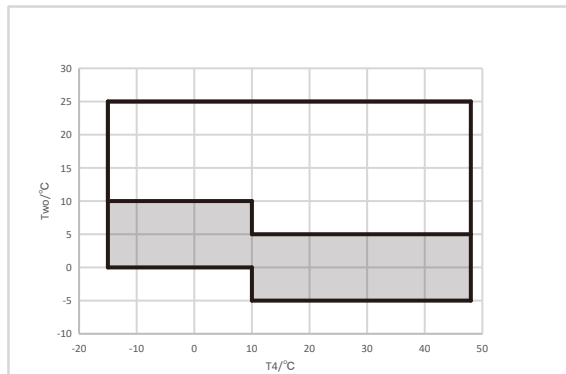

Fig. 4-21 Cooling operating range

**50/60/70 kW
HEATING**

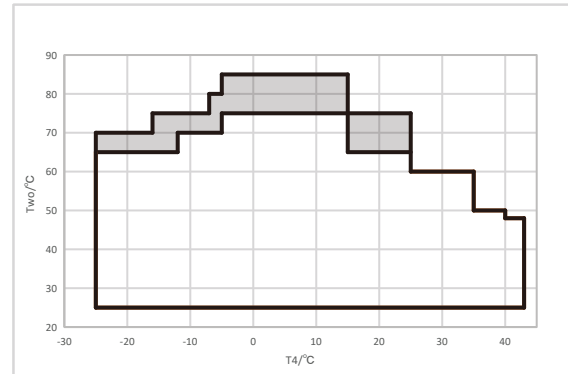

Fig. 4-22 Heating operating range

**50/60/70 kW
DHW**

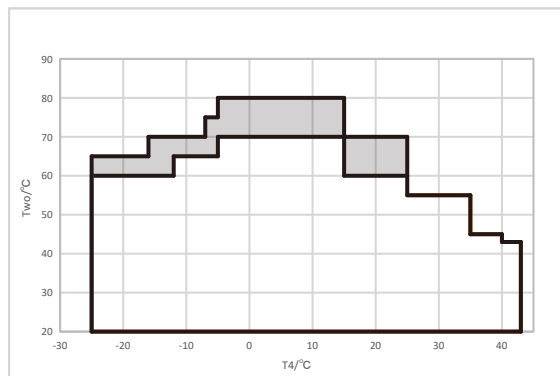

Fig. 4-23 DHW operating range

1) Cooling

If the equipment runs within the temperature range of the shaded area, an antifreeze system must be used instead of a water system, and the antifreeze (especially ethylene glycol solution) must meet both the following requirements:

- ① The concentration is greater than or equal to 30%;
- ② The freezing point of the antifreeze is 5.5°C lower than the lowest temperature at the usage location. Otherwise, the water-side pipes and heat exchangers may freeze.

When the Tsafe is set to -5°C in the service menu of the wired controller, the equipment will enter the low-temperature water outlet cooling mode to obtain water discharge below 5°C.

When switching from the antifreeze system to the water system, Tsafe must be set to 5°C to prevent the water-side pipes and heat exchangers from freezing.

2) Heating

If the equipment runs within the temperature range in the shaded area, the DIP switch S1-2 needs to be set to ON.

If the equipment runs within the temperature range of the shaded area, a variable frequency water pump must be matched, and the minimum water flow rate of the water pump shall be able to be as low as 1.8 m³ per hour.

3) Anti-freezing protection for plate heat exchangers

The heat exchanger shall be completely drained and cleaned with antifreeze. Otherwise, other antifreeze measures shall be taken.

When designing the entire system, the following protection methods must be taken into account:

- ① Continuous circulation of water flow inside pipes and heat exchangers;
- ② Add an appropriate amount of antifreeze to the water circuits, or provide additional insulation and heating for exposed pipes (both inside and outside the unit).
- ③ If the unit doesn't work in winter, the heat exchanger shall be drained and cleaned.

It is the responsibility of the installer or local maintenance personnel to ensure that the above anti-freezing methods are taken; failure to follow the above instructions may result in damage to the unit.



WARNING

Damage caused by freezing is not covered by the warranty. We will not be held responsible for it in any way.

5 ELECTRICAL INSTALLATION

5.1 General specifications

Please refer to the specific wiring diagram of the equipment you have purchased. If the equipment does not come with a wiring diagram or the diagram is lost, please contact the manufacturer's authorized representative, who will provide you with a copy of the drawing. In the event of any differences between the wiring diagram and the actual layout of the electrical control cabinet/cables, please contact the manufacturer's representative immediately.



WARNING

All electrical connections of this machine must be made in accordance with current laws and regulations. All installation, operation and maintenance tasks must be carried out by qualified professionals. Otherwise, there will be a risk of electric shock.

This electrical equipment can run normally under the nominal environment temperature. In extremely high or low temperature environments, it is recommended to take additional protective measures (please contact the manufacturer's representative). The equipment design has avoided the potential hazards of condensation. Additional protective measures can be taken if necessary (please contact the manufacturer's representative).

This product complies with the electromagnetic compatibility (EMC) standards for industrial environments and is therefore not suitable for use in residential areas or other places that need to be connected to low-voltage public distribution systems. If it is necessary to be connected to the public power distribution system, special protective measures must be taken to avoid electromagnetic interference to other sensitive equipment.

5.2 Electrical supply

Electrical equipment can run normally under the following specific conditions:

Voltage: Steady-state voltage, 0.9 to 1.1 times the rated voltage.

Harmonics: The 5th harmonic current shall not exceed 40% of the fundamental current, the 7th harmonic current shall not exceed 25% of the fundamental current, the 11th harmonic current shall not exceed 15% of the fundamental current, and the 13th harmonic current shall not exceed 10% of the fundamental current.

Voltage sag: A voltage sag does not exceed 20% of the peak supply voltage, lasts for more than one cycle, and the time between consecutive sags is over 1 second.

5.3 Electrical connections

5.3.1 Safety precautions

1) On-site wiring, components and materials must comply with local and national regulations as well as relevant national electrical standards.



Fig. 5-1 Electrical wiring precaution (a)

2) Copper core wires must be used.

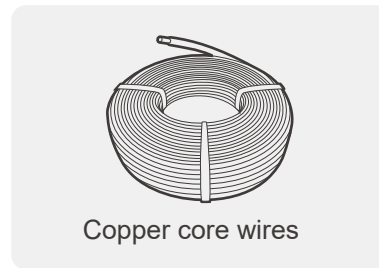

Fig. 5-2 Electrical wiring precaution (b)

3) It is recommended that three-core shielded cables be used between equipment to reduce interference. Do not use non-shielded multi-core wire cables.



Fig. 5-3 Electrical wiring precaution (c)

4) The power wiring must be delegated to professionals with electrician qualifications to complete.

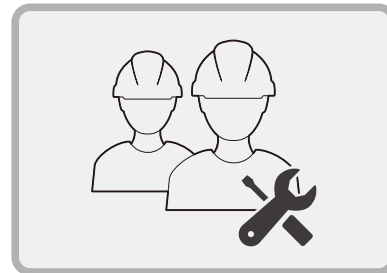

Fig. 5-4 Electrical wiring precaution (d)

The electrical circuits shall be provided for connecting the units. Connections must be made using copper cables with a cross-sectional area that matches the value indicated on the equipment nameplate and complies with current electrical standards. We shall not be held responsible for any improper electrical connections.

WARNING

Wiring must use copper terminals and cables; otherwise, the connection points may overheat or corrode, posing a risk of machine damage. Electrical connections must be carried out by qualified personnel in accordance with current laws and regulations, posing a risk of electric shock.

The power supply for this machine must be configured so that it can be switched on and off independently of other system components and general equipment through a main switch.

The electrical connection of the panel must be subjected to the correct phase sequence. Please refer to the dedicated wiring diagram provided with the purchased machine for wiring. If no wiring diagram is found on the device or it has been lost, please contact the manufacturer's designated agent to obtain a copy. When there are differences between the wiring diagram and the actual electrical control cabinet/cables, please contact the manufacturer's designated agent immediately.

WARNING

Do not apply torque, tension or heavy loads to the main switch terminals. The power cables must be fixed by an appropriate support system.

To avoid interference, all control lines must be connected separately from the power cords. For this purpose, multiple wire conduits need to be used.

When single-phase and three-phase loads are running simultaneously and there is phase imbalance, the equipment may cause up to 150 mA of ground loss during normal running. If the equipment contains devices that generate high harmonics (e.g. inverters), the grounding loss may increase significantly to a high value of approximately 2 A.

The protective devices of the power supply system must be designed in accordance with the above values. Each phase must be equipped with a fuse, and a ground fault detector (if applicable) must be installed in accordance with the legal requirements of the country where the equipment is installed. This machine complies with the electromagnetic compatibility (EMC) standards for industrial environments and is therefore not suitable for use in residential areas or other similar locations (e.g. scenarios where the product is connected to a public low-voltage distribution system). If this machine accesses to a public low-voltage distribution system, specific additional measures must be taken to prevent interference with other sensitive equipment.

5.3.2 Electric wiring

CAUTION

The unit must be powered by a dedicated power supply, and its voltage must meet the rated voltage requirements.

Line construction must be carried out strictly in accordance with the circuit diagram by professional technicians.

The power cord and grounding wire must be correctly connected to the corresponding terminals and securely fastened in place with the appropriate tools.

The connection terminals of the power cord and grounding wire shall be assured to be fully tightened and checked regularly to prevent loosening.

Only the electrical components designated by the Company can be used. The relevant installation and technical services must be provided by the manufacturer or authorized dealers. If the wiring connection does not comply with the electrical installation standards, it may lead to various safety hazards such as controller failure and electric shock.

Leakage protection devices must be installed in accordance with the national technical standards for electrical equipment.

After the completion of all the line construction, be sure to carefully inspect each connection point. Only after confirming that everything is correct can the power be connected.

Please read carefully all the warning signs on the electrical control cabinet.

Users are strictly prohibited from repairing the controller by themselves. Improper operation may lead to serious consequences such as electric shock and controller damage.

If the equipment needs repair, please contact a professional maintenance center. Any maintenance needs must be handled by the maintenance center. Non-professional maintenance may lead to risks such as electric shock and machine damage.

Explanation of harmonic current short-circuit ratio

NOTE

We declare the model MHS-SVC70-RN7TL-B. This equipment complies with IEC 61000-3-12 provided that the Short-circuit power S_{sc} is greater than or equal to 15518.72kW at the interface point between the user's supply and the public system. It is the responsibility of the installer or user of the equipment to ensure, by consultation with the distribution network operator if necessary, that the equipment is connected only to a supply with a short-circuit power S_{sc} greater than or equal to 15518.72kW.

We declare the model MHS-SVC60-RN7TL-B. This equipment complies with IEC 61000-3-12 provided that the Short-circuit power S_{sc} is greater than or equal to 15033.76kW at the interface point between the user's supply and the public system. It is the responsibility of the installer or user of the equipment to ensure, by consultation with the distribution network operator if necessary, that the equipment is connected only to a supply with a short-circuit power S_{sc} greater than or equal to 15033.76kW.

We declare the model MHS-SVC50-RN7TL-B. This equipment complies with IEC 61000-3-12 provided that the Short-circuit power S_{sc} is greater than or equal to 14548.8kW at the interface point between the user's supply and the public system. It is the responsibility of the installer or user of the equipment to ensure, by consultation with the distribution network operator if necessary, that the equipment is connected only to a supply with a short-circuit power S_{sc} greater than or equal to 14548.8kW.

1) Cable requirements

The cables connected to the circuit breaker must comply with the requirements for electrical clearance and creepage distance between live conductors and earthed parts as specified in Tables 1 and 2 of IEC 61439-1, and also conform to local national regulations. The cable connected to the main switch shall be tightened with a double wrench. Follow the uniform tightening torque value based on the quality of the washers, screws and nuts used.

The grounding conductor (yellow/green bicolour wire) must be connected to the PE grounding terminal. The cross-sectional area of the equipotential bonding conductor (grounding wire) shall comply with the provisions of Table 1 in Clause 5.2 of EN 60204-1 standard (as shown below). According to Clause 8.2.8 of this standard, the cross-sectional area of the equipotential bonding conductor (grounding wire) shall not be less than 10 mm² under any circumstances.

Table 5 -1 Point 5.2 of EN60204-1

Section of the copper phase conductors feeding the equipment S [mm ²]	Minimum cross-section of the external copper protection conductor Sp [mm ²]
S ≤ 16	S
16 < S ≤ 35	16
S > 35	S/2

2) Operating current and wire diameter

Please select the wire gauge (minimum value) for each unit based on Table 6-3 and Table 6-4 respectively. The rated current in Table 6-3 corresponds to the MCA (Minimum Circuit Ampacity) in Table 6-4.

The maximum allowable phase-to-phase voltage deviation is 2%, and the power line length is less than 20 m.

MFA (Maximum Fuse Ampere) is used to select current circuit breakers.

The electric control box is equipped with an overcurrent protector (fuse). If additional overcurrent protectors are needed, please refer to the TOCA (Total Overcurrent Protection Value) parameter in Table 6-4 for selection.

Table 5-2

Rated current (A)	Nominal cross-sectional area (mm ²)	
	Flexible cord	Cable for fixed wiring
≤ 3	0.5 and 0.75	1 and 2.5
>3 and ≤6	0.75 and 1	1 and 2.5
>6 and ≤10	1 and 1.5	1 and 2.5
>10 and ≤16	1.5 and 2.5	1.5 and 4
>16 and ≤25	2.5 and 4	2.5 and 6
>25 and ≤32	4 and 6	4 and 10
>32 and ≤50	6 and 10	6 and 16
>50 and ≤63	10 and 16	10 and 25
>63 and ≤95	16 and 25	25 and 35

Table 5-3

System	Outdoor unit				Power current		
	Voltage (V)	Hz	Min. (V)	Max. (V)	MCA (A)	TOCA (A)	MFA (A)
50kW 3-PH	380-415	50	342	456	65	75	85
60kW 3-PH	380-415	50	342	456	67	75	85
70kW 3-PH	380-415	50	342	456	69	75	85

MCA: min. circuit current. (A)

TOCA: total over current (A)

MFA: max. fuse current (A)

NOTE

When the voltage drop at the power supply wiring point does not exceed 2%, please refer to the above description to select the power supply wire diameter and length. If the length of the conductor exceeds the value specified in the instructions or the voltage drop overruns the limit, the diameter of the power supply line shall be increased in accordance with relevant regulations.

3) Power connection

① Main power connection

⚠ CAUTION

- Connect to the power terminal board using circular crimp terminals.
- A leakage protection switch must be installed.

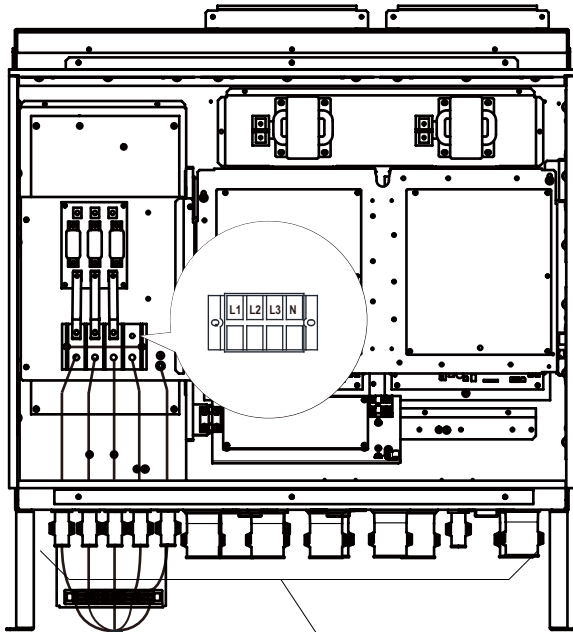

All the grommets under the electrical control box have been tied up at the factory. After installation and maintenance, they need to be tied up again with cable ties.

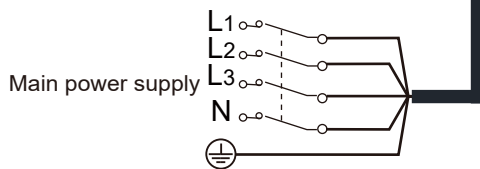

Fig. 5-5

② Connection of other components

The mainframe expansion board provides two control ports:

Type 1: Strong current control (For specific wiring methods, please refer to the wiring nameplate.)

Type 2: Weak Current Detection (For specific wiring methods, please refer to the wiring nameplate.)

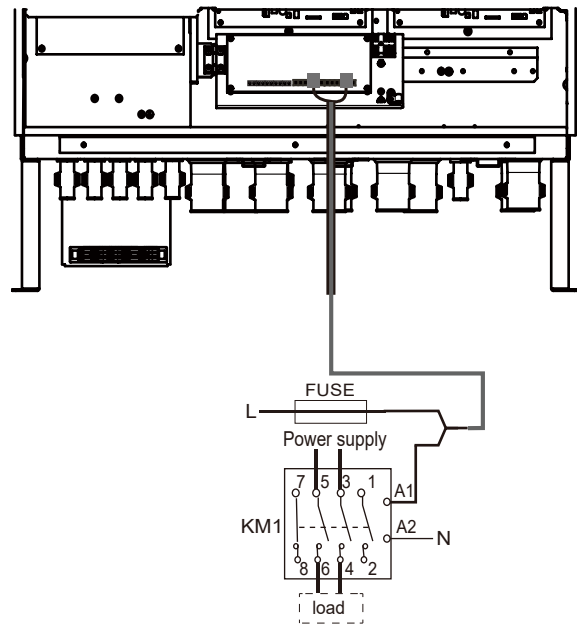

Fig. 5-6 Type 1

L-N Voltage	220-240 VAC
Maximum running current (A)	0.2
Minimum wire size (mm ²)	0.75
Control port signal type	Type 1

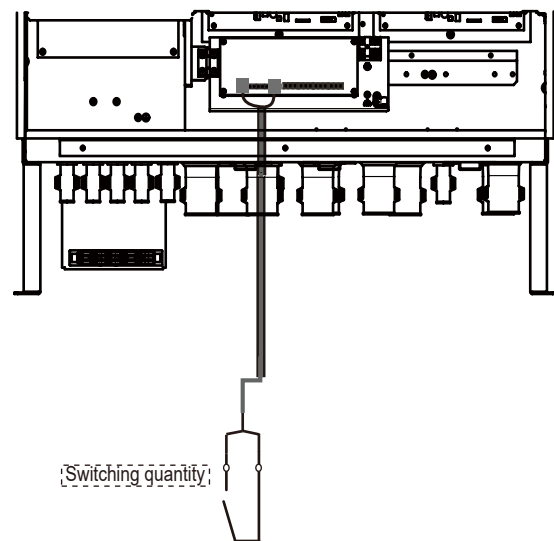

Fig. 5-7 Type 2

💡 NOTE

Type 2 must be of low voltage.

5.3.3 Power connection requirements

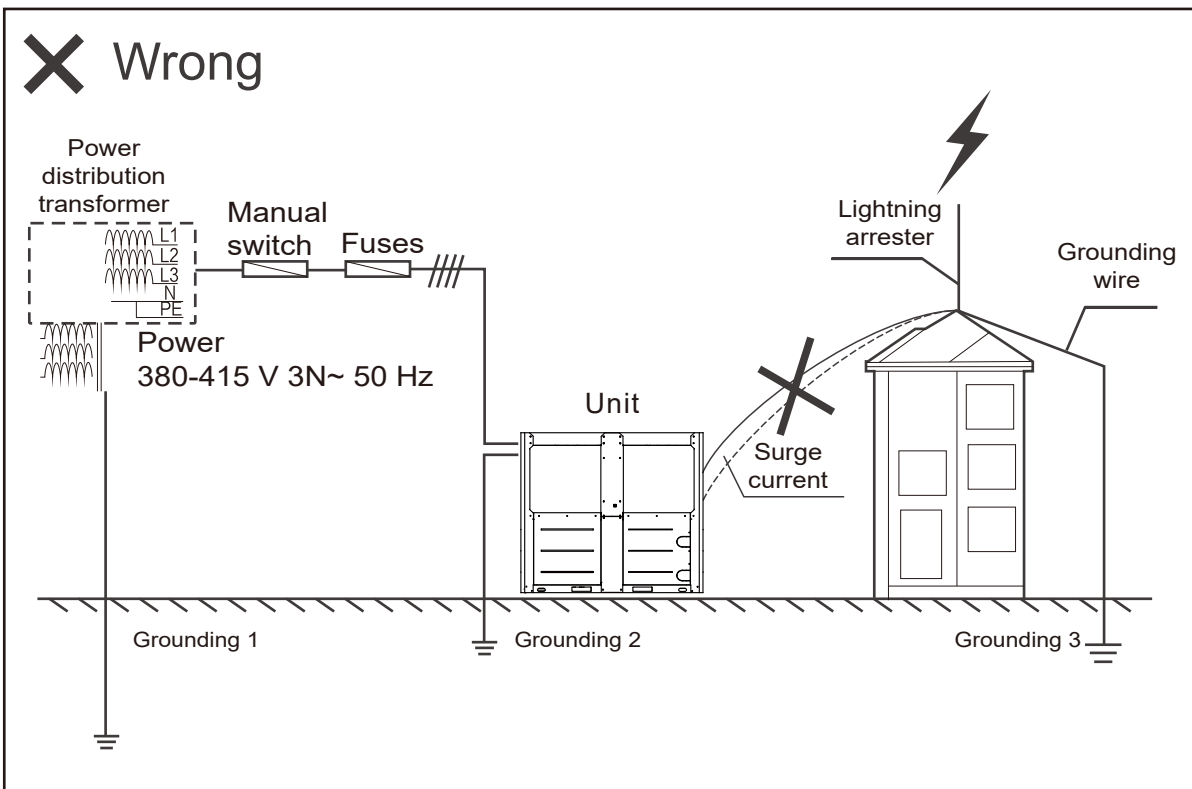
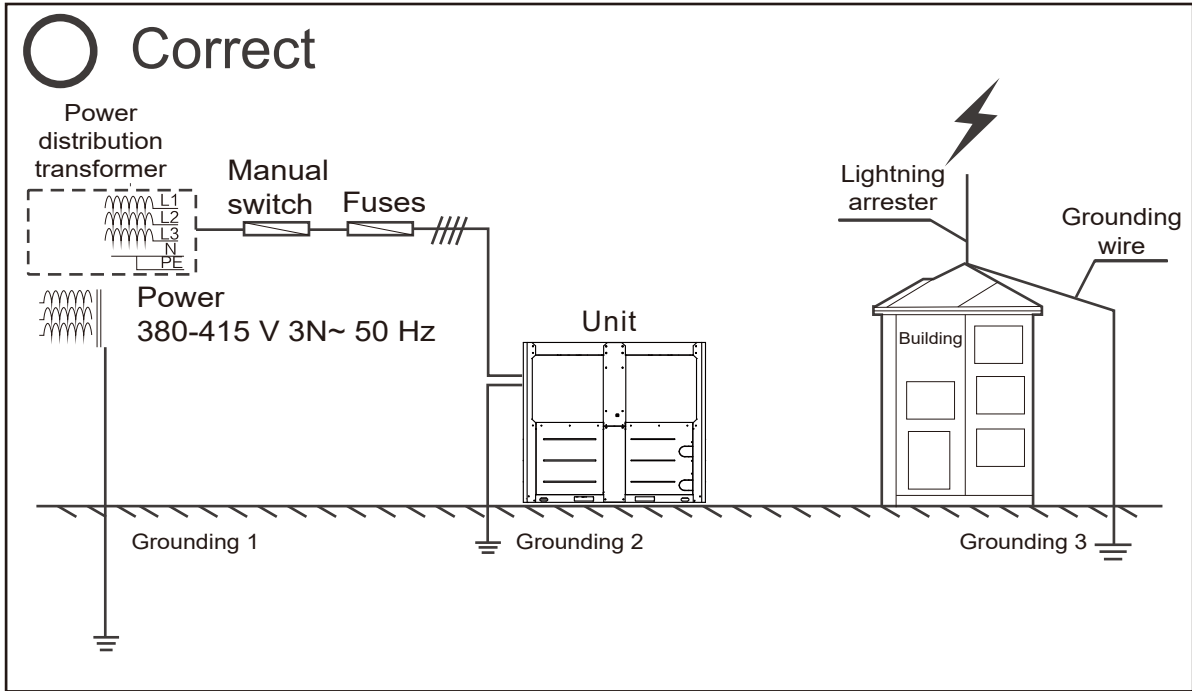

Fig. 5-8

NOTE

Do not connect the grounding wire of the lightning arrester to the equipment enclosure. The grounding wire of the lightning arrester must be separately configured from the grounding wire of the power supply.

5.3.4 Power cable wiring requirements

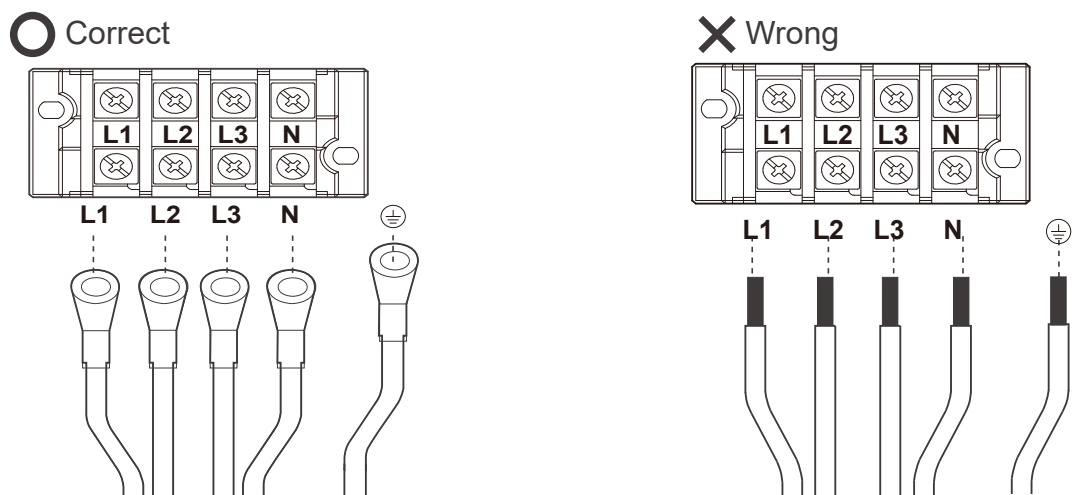

Fig. 5-9 Requirements for power cord connection

NOTE

Please connect the power cord with the correct specification of round terminals.

5.3.5 Overall

If multiple equipment are connected in parallel, the unit address should be set on DIP switch ENC1. With 0-F being valid (hexadecimal), 0/1 indicates the master unit and 2-F indicates the slave units.

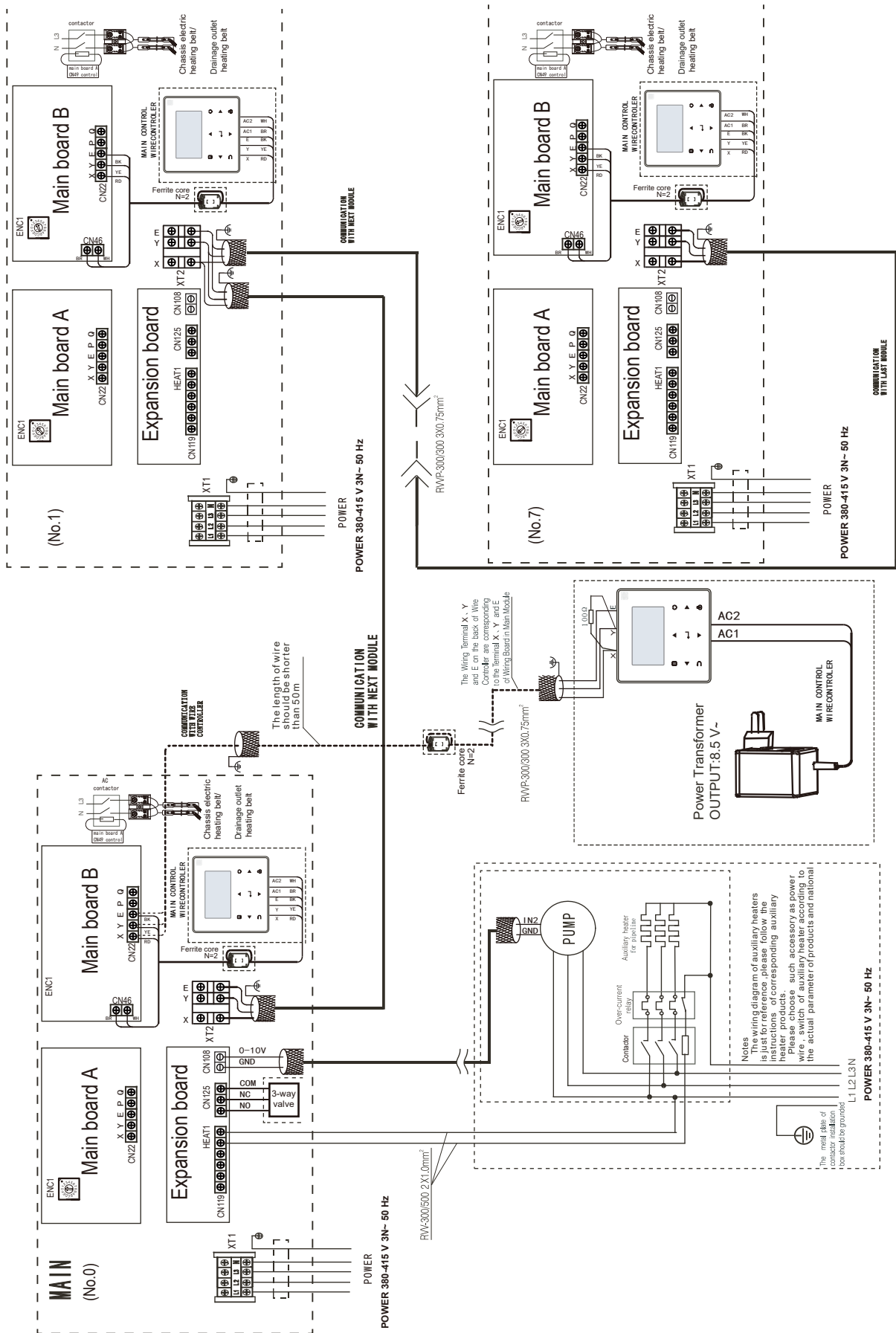

Fig. 5-10 Networking communication schematic of main unit and auxiliary unit for 50/60/70kW

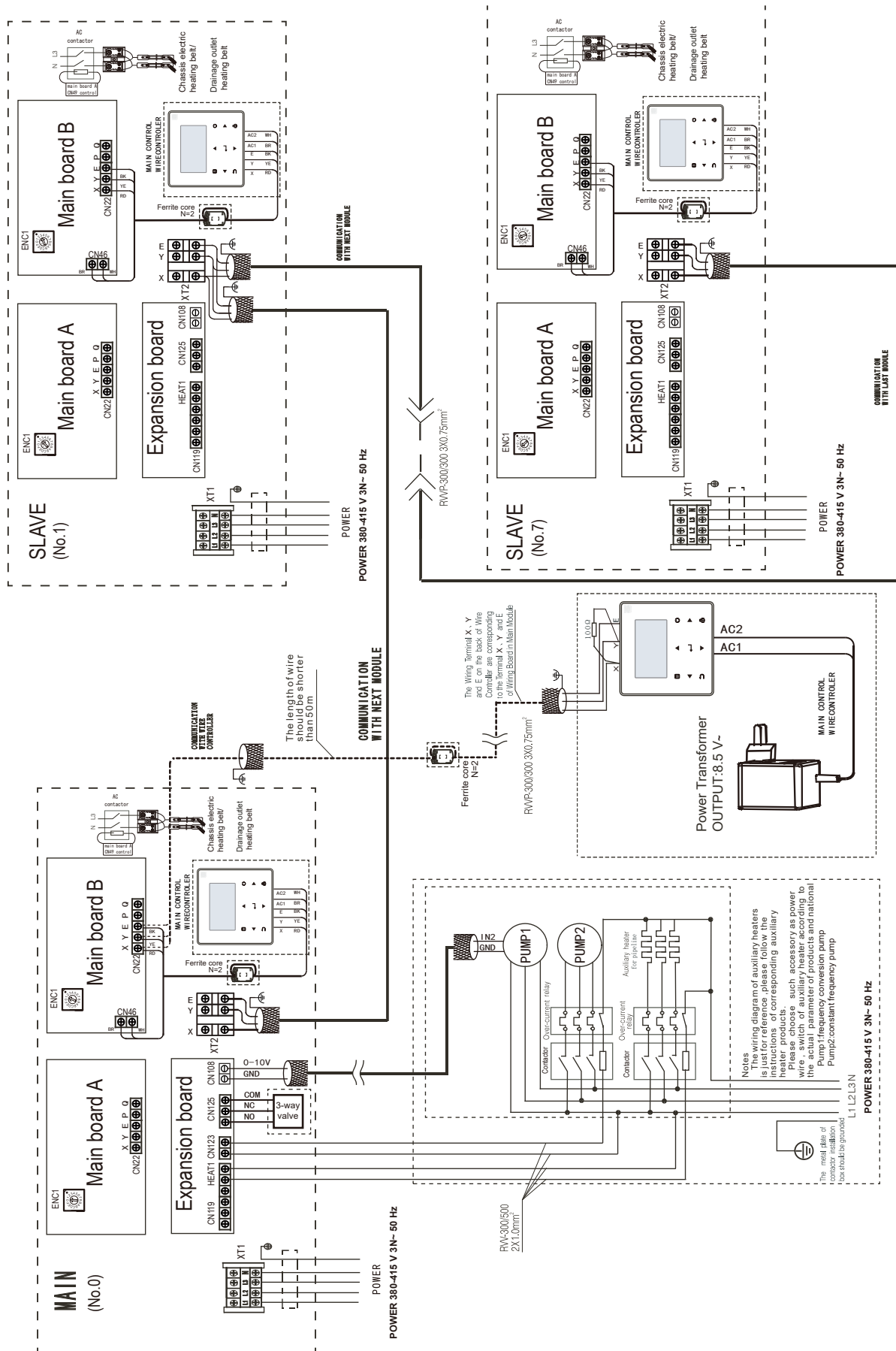

Fig. 5-11 Networking communication schematic of main unit and auxiliary unit for 50/60/70kW

NOTE

When power cords and signal wires are arranged in parallel, it is necessary to ensure that they maintain a reasonable distance from each other. (The standard spacing between power cords and signal wires: maintain a 300 mm distance when the current is less than 10 A, and a 500 mm distance when the current is less than 50 A.)

⚠ CAUTION

In the case of multi-unit connection, HMIs in the same system can be connected in parallel.

5.3.6 Function of terminals

As shown in the figure (Note: See the figure below), the communication signal wire of the unit needs to be connected to the XT2 terminal block at the XYE position inside the electrical control box;

The signal wire of the wired controller needs to be connected to the CN22 terminal block at the XYE position on the main board B inside the electronic control box.

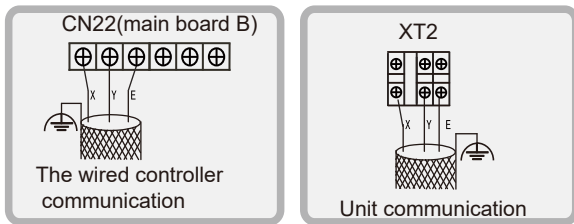

Fig. 5-12

As shown in the figure below, For 50/60/70kW, the unit communication signal wire is connected to the terminal block XT2 at XYE inside the electric control box.

The wired controller signal wire is connected to the terminal block CN22 at XYE on main board B inside the electric control box.

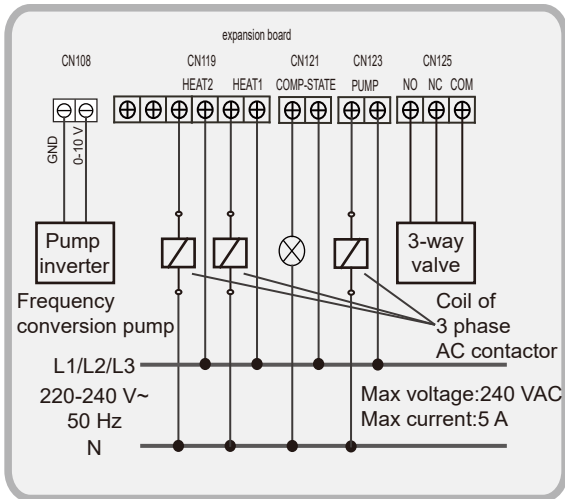

Fig. 5-13 Wiring of pipeline auxiliary heater and ac light of the state of compressor(50/60/70kW)

5.3.7 Wiring of "ON/OFF" weak electric port

The "ON/OFF" remote control function must be set via the DIP switch. When S1-1 is selected as the ON state, the "ON/OFF" remote control function will take effect, and the wired controller will lose control.

The "ON/OFF" ports inside the unit's electric control box need to be connected in parallel. Then, the "ON/OFF" signal provided by the user shall be connected to the unit's "ON/OFF" port in the following manner:

Short-circuit the terminal block CN137 on the expansion board inside the electronic control box to enable the "ON/OFF" remote control function.

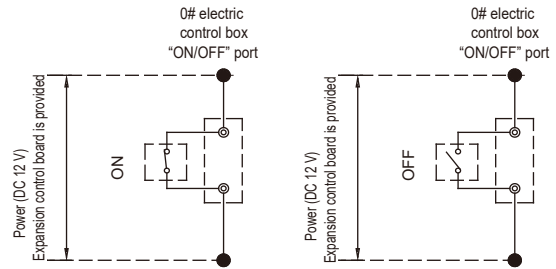

Fig. 5-14 Wiring of "ON/OFF" weak electric port

5.3.8 Wiring of "HEAT/COOL" weak electric port

The "HEAT/COOL" remote control function must be set via the DIP switch. When S1-1 is selected as the ON state, the "HEAT/COOL" remote control function will take effect, and the wired controller will lose control.

To enable the remote control function of "HEAT/COOL", the "HEAT/COOL" ports inside the unit's electric control box need to be connected in parallel. Then, connect the "HEAT/COOL" signal provided by the user to the corresponding port of the unit in the following way: short-circuit the terminal block CN138 on the expansion board inside the electric control box.

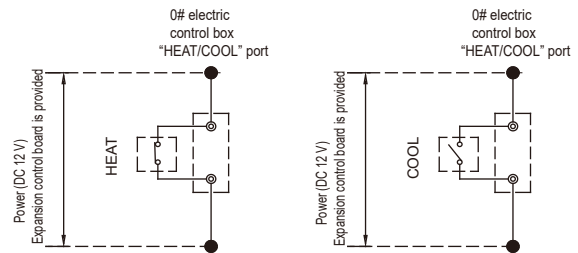

Fig. 5-15 Wiring of "HEAT/ COOL" weak electric port

5.3.9 Wiring of "TEMP-SWITCH" weak electric port

The "TEMP-SWITCH" (temperature switching) function requires setting two water temperature modes via the wired controller. To select the target water temperature, short-circuit terminal block CN110 on the expansion board inside the electric control box.

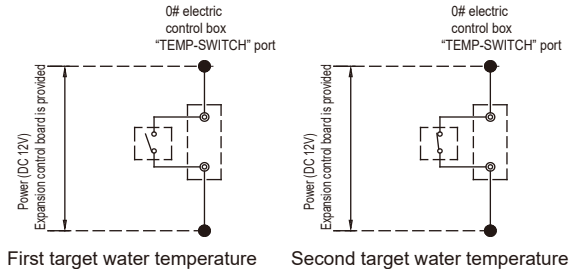

Fig. 5-16 Wiring of "TEMP-SWITCH" weak electric port

5.3.10 Wiring of "ALARM" port

Users need to connect their self-prepared equipment to the "ALARM" port of the module unit in the following manner.

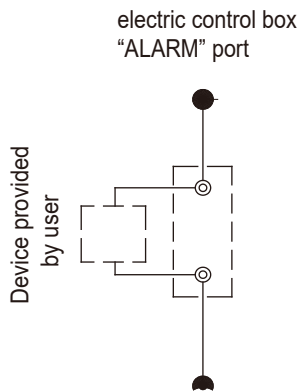

Fig. 5-17 Wiring of "ALARM" port

When the unit runs abnormally, the ALARM port will close (conduct); when it runs normally, the ALARM port will open.

The ALARM port is located on the main control board A. For specific wiring, please refer to the wiring diagram.

5.3.11 Control system and installation precautions

1) Shielded wires must be used as control lines. Other types of wires may cause signal interference, leading to malfunctions in the operation of the unit.



Fig. 5-18 Control system and installation precaution (a)

2) The shielding layers at both ends of the shielded wire must be reliably grounded. Alternatively, connect the shielding layers of all the shielded wires to each other and then ground them through a single metal plate.

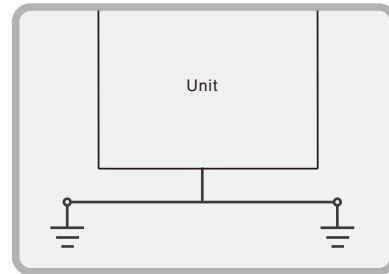

Fig. 5-19 Control system and installation precaution (b)

3) It is prohibited to bundle the control lines with the refrigerant pipes and power cords. When power cords and control lines are laid in parallel, a distance of more than 300 mm shall be maintained to prevent interference from the signal source.

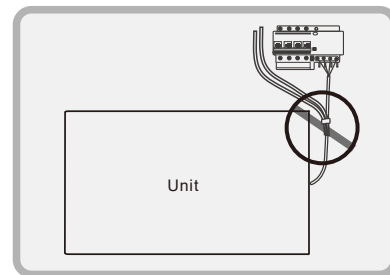

Fig. 5-20 Control system and installation precaution (c)

4) When performing wiring operations, it is necessary to pay attention to the polarity of the control line.

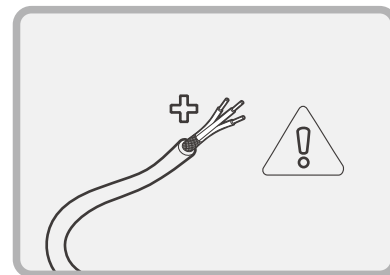

Fig. 5-21 Control system and installation precaution (d)

NOTE

When the customer is wiring, first cut off the zip ties at the customer's wiring port below the electric control box, and then proceed with the wiring. After completion, use zip ties to fix and tighten the wire sealing ring (zip ties are included in the attachment).



5.4 PCB

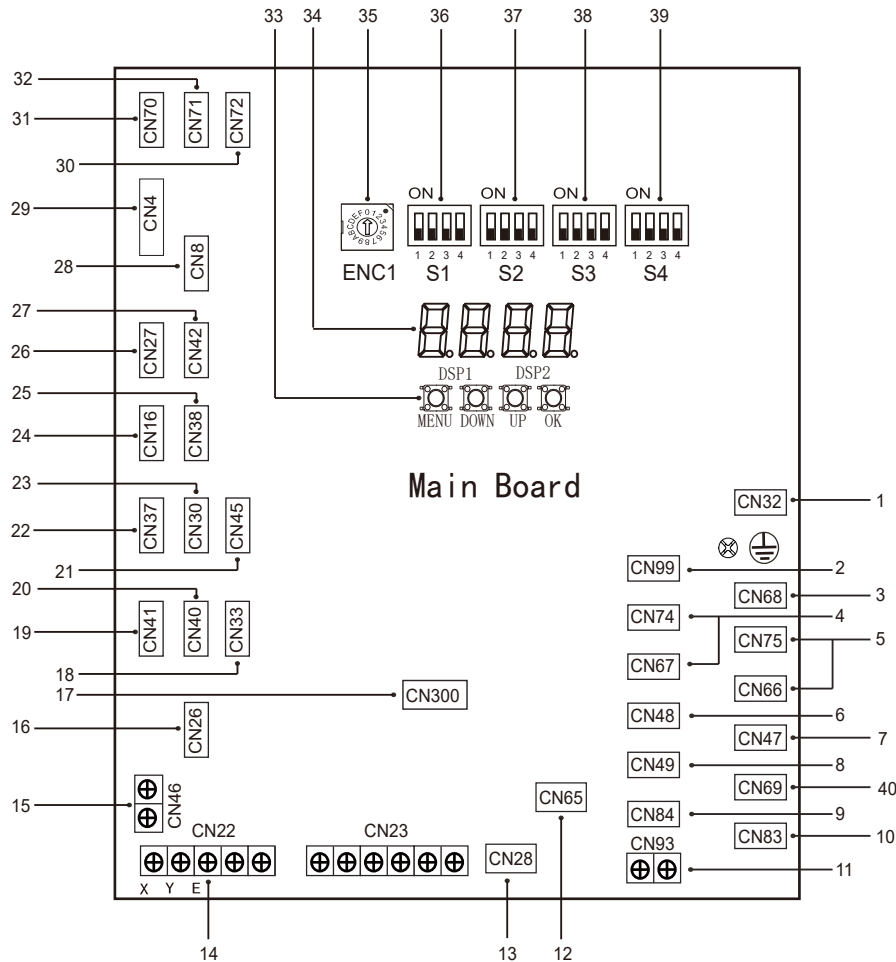

Fig. 5-22 Main board of 50/60/70KW

Table 5-4

NO.	Port Code	Content	Voltage	Direction
1	CN32	Main board power supply	230 V AC	Input
2	CN99	Expansion board power supply	230 V AC	Output
3	CN68	Reserved	230 V AC	Output
4	CN74/CN67	Reserved/Crankcase Heater	230 V AC	Output
5	CN75/CN66	Reserved/Electronic heating belt for plate heat exchanger	230 V AC	Output
6	CN48	Four-way valve	230 V AC	Output
7	CN47	Solenoid valve	230 V AC	Output
8	CN49	Water tray electric heating belt, Water pipe electric heating belt	230 V AC	Output
9	CN84	Reserved	0 V	Output
10	CN83	Reserved	0 V	Output
11	CN93	The alarm signal output of the unit(ON/OFF signal)		Input/Output
12	CN65	Program burn in port(USB)	5 V DC	Input/Output
13	CN28	Three-phase protector output switch	12 V DC	Input
14	CN22	Outdoor units communication and wired controller communication port	5 V DC	Output
15	CN46	The power supply port of the wired controller	12 V DC	Output
16	CN26	Compressor inverter module and Fan inverter module communication ports	12 V/5 V DC	Input/Output

Table 5-5

NO.	Port Code	Content	Voltage	Direction
17	CN300	Program burn in port	3.3 V DC	Input/Output
18	CN33	Communicate with slave board	12 V/3.3 V DC	Input/Output
19	CN41	System low pressure sensor	5 V DC	Input
20	CN40	System high pressure sensor	5 V DC	Input
21	CN45	Probe of outlet water side antifreeze temp	3.3 V DC	Input
22	CN37	pipe temperature sensor of the condenser	3.3 V DC	Input
23	CN30	outdoor ambient temperature sensor	3.3 V DC	Input
24	CN16	Reserved	3.3 V DC	Input
25	CN38	Reserved	3.3 V DC	Input
26	CN27	Discharge temperature switch protection (protection code P0, prevent the compressor from over temperature 115 ℃)	3.3 V DC	Input
27	CN42	Reserved	3.3 V DC	Input
28	CN8	Refrigerant inlet temperature of EVI plate heat exchanger/ Refrigerant outlet temperature of EVI plate heat exchanger	3.3 V DC	Input
29	CN4	Unit water inlet temperature sensor	3.3 V DC	Input
		System suction temperature sensor		
		Unit water outlet temperature sensor		
		coil final outlet temperature sensor		
		DC inverter compressor discharge temperature sensor		
30	CN72	Port for electrical expansion valve C	12 V DC	Output
31	CN70	Port for electrical expansion valve A	12 V DC	Output
32	CN71	Port for electrical expansion valve B	12 V DC	Output
33	SW3	Up button	3.3 V DC	Input
	SW4	Down button		
	SW5	Menu Buttons		
	SW6	Confirm button		
34	DSP1/DSP2	Digital tube 1) In case of stand-by, the address of the module is displayed; 2) In case of normal operation, 10. is displayed (10 is followed by dot). 3) In case of fault or protection, fault code or protection code is displayed.	3.3 V DC	Output
35	ENC1	ENC1:NET_ADDRESS DIP switch 0-F of outdoor unit network address is enabled, which represent address 0-15.	3.3 V DC	Input
36	S1	Dip switch	3.3 V DC	Input
37	S2	Reserved	3.3 V DC	Input
38	S3	Dip switch	3.3 V DC	Input
39	S4	Dip switch	3.3 V DC	Input
40	CN69	Reserved	230 V AC	Output

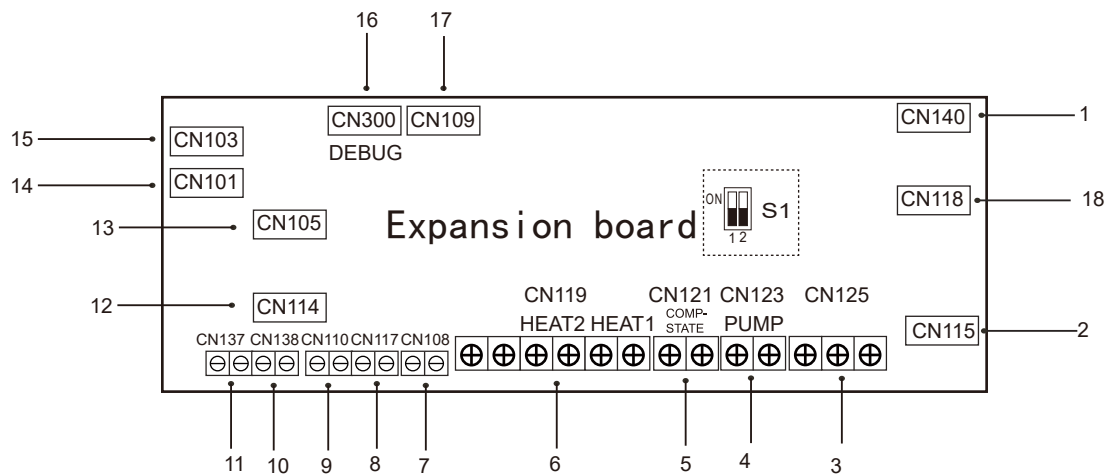

Fig. 5-23 Expansion Board of 50/60/70KW

NO.	Port Code	Content	Voltage	Direction
1	CN140	Expansion board power supply	230 V AC	Input
2	CN115	Electric heater of water flow switch	230 V AC	Output
3	CN125	Three-way valve(hot-water valve)	230 V AC	Output
4	CN123	Port controlled by the contactor of the constant speed water pump		Input/Output
5	CN121	Compressor status indication		Input/Output
6	CN119	Pipeline Auxiliary Heater/Hot Water Tank Auxiliary Heater		Input/Output
7	CN108	Inverter pump 0-10V output control signal	0-10 V DC	Output
8	CN117	Water pressure switching port.	12 V DC	Input
9	CN110	Target water temperature switch	12 V DC	Input
10	CN138	Remote function of cool/heat signal	12 V DC	Input
11	CN137	Remote function of on/off signal	12 V DC	Input
12	CN114	Water flow switch signal	12 V DC	Input
13	CN105	Probe of inlet water side antifreeze temp	3.3 V DC	Input
14	CN101	Probe of finaunit water outlet temp	3.3 V DC	Input
15	CN103	Probe of water tank	3.3 V DC	Input
16	CN300	Program burn in port	3.3 V DC	Input/Output
17	CN109	Communicate with main board	12 V/3.3 V DC	Input/Output
18	CN118	Reserved	230 V AC	Output

⚠ CAUTION

Faults

When the master unit malfunctions, it will stop running and all slave units will cease running as well; when a slave unit malfunctions, only that unit will stop running and the others remain unaffected.

Protection

When the master unit is in a protective state, only that unit will stop running while the others remain running; when a slave unit is in a protective state, only that unit will stop running and the others will not be affected.

5.5 DIP switch settings description

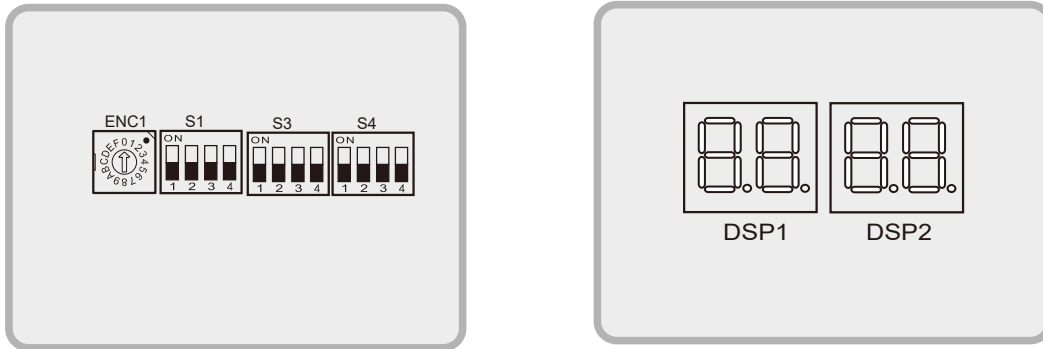

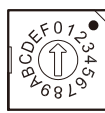



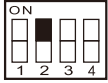

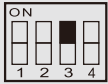
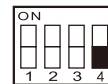
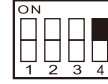



Fig. 5-24 Display Positions

Table 5-7

		Meaning	Notes	
ENC1 System address		0-F	Each unit is composed of two independent refrigerant circulation systems, each corresponding to its own address DIP switch. Specially, address 0 corresponds to the System A of the main unit, address 1 corresponds to the System B of the main unit, and the address DIP switch settings of other unit control systems shall be carried out in ascending order.	Set the address DIP switch of the main unit system A to 0#; each refrigerant circulation system needs to set the address DIP switch separately; the address DIP switch of different systems must not be repeated.
S1-1 Remote control		OFF	When the DIP switch is off, the device cannot use the remote control function and can only be controlled by the wired controller (ex-factory default).	This adjustment is only applicable to Main Unit 0# and is invalid for other addresses.
		ON	When the DIP switch is turned on, the remote control function of the unit will take effect. 1. The start and stop of the unit can be controlled through the ON/OFF port on the main board expansion board: shorting-circuit starts the unit, while disconnecting shuts down the unit. 2. The running mode of the unit can be adjusted through the H/C port on the expansion board: shorting-circuit for heating mode and disconnecting it for cooling mode. 3. If the unit is connected to a wired controller, the wired controller can only change parameters such as the set temperature and recovery from startup errors (if not connected to a wired controller, the default values will control).	

S1-2		OFF	When the DIP switch is off, the maximum temperature for the heating mode can be set to 75 °C (ex-factory default).	In a system controlled by the same wired controller, each subsystem needs to select the S1-2 setting, and all subsystems shall maintain the same selection.
		ON	When the DIP switch is turned on, the maximum temperature for the heating mode can be set to 85 °C. Note: This DIP switch is only applicable to units equipped with variable frequency water pumps and whose water flow range meets the Company's requirements; otherwise, it may result in the unit being unable to reach the set temperature.	
S1-3		OFF	When all units controlled by the same wired controller share the same main water pump, this dial code should be OFF (factory default).	Single unit this dial code should be off; It is necessary to select S1-3 in the parallel system controlled by the same line controller, and the selection should be consistent, otherwise the fault FP will be displayed. The model of all pumps in the same parallel system should be uniform.
		ON	When each unit in a system controlled by the same wire is equipped with a separate water pump, this dial should be ON.	
S1-4		OFF	When a single unit is matched with a single fixed-speed water pump or a single variable-frequency water pump, this DIP switch shall be set to OFF (ex-factory default value).	For each system controlled by the same line controller, the S1-4 DIP switch configuration must be selected.
		ON	When the hydraulic equipment of a single unit adopts a combination of fixed-speed pumps and parallel variable-frequency pumps, this switch shall be set to ON. When the DIP switch is turned on, the system will perform coordinated regulation of the constant-speed water pump and the variable-frequency water pump.	
S3-1		OFF	This DIP switch is used to distinguish between System A and System B within a single unit. When the DIP switch is in the off position, the system will be System A; when the DIP switch is on, the system will be System B.	This DIP switch has been pre-set and does not need to be changed during installation and commissioning. If a fault occurs, check whether the DIP switch settings are correct.
		ON		

6 RESPONSIBILITIES OF OPERATORS

Before operating the equipment, the operators must receive appropriate training and be familiar with the system operation process. In addition to reading this Manual, operators must study other relevant operation manuals and wiring diagrams and other related documents to understand the startup sequence, operation procedures, shutdown sequence, and the operation of all safety devices.

During the initial startup phase of the equipment, the manufacturer-authorized technicians shall answer any questions and guide the correct operation procedures and sequence.

The operators must record operation data for each installed equipment and keep a record of all regular maintenance and assistance activities.

If the operator discovers any abnormal or unusual operating conditions, it is recommended to consult the manufacturer's authorized technical service personnel.

NOTE

This unit needs to be properly maintained to ensure it is always in good working condition.

During use and maintenance, the following safety regulations must be strictly adhered to:

- Unauthorized and/or unqualified personnel are prohibited from accessing the unit;
- It is strictly prohibited to touch electrical components without disconnecting the main switch of the unit and cutting off the power supply;
- Do not touch electrical components when not using an insulated platform;
- In the event of standing water or a damp environment on site, do not operate electrical components;
- All operations on the refrigerant circuit and pressure components must be carried out by professional technicians;
- Compressor replacement is only to be carried out by qualified personnel;
- The finned heat exchanger area has sharp edges and high-temperature surfaces, which may cause injury; direct contact shall be avoided and protective devices shall be provided;
- When connecting the unit to the system, it is strictly prohibited to throw solid foreign objects into the water pipes;
- It is strictly prohibited to remove the protective devices from moving parts;
- It is recommended that installation and maintenance task be carried out collaboratively by multiple personnel;

NOTE

In case of accidental injury or physical discomfort:

- ① Keep calm;
- ② If an alarm device is available on site, trigger the alarm immediately;
- ③ Contact emergency medical personnel or a medical emergency service immediately;
- ④ Stay with the injured until rescue personnel arrive;
- ⑤ Give the rescue workers a complete account of the accident details.

WARNING

Avoid installing the equipment in areas where there may be hazards during maintenance operations, such as platforms without guardrails or handrails, or areas that do not meet the spacing requirements around the equipment.

7 MAINTENANCE

Personnel engaged in electrical or cooling component operations must be authorized, professionally trained and fully qualified. Maintenance and repair task that requires the assistance of other professionals shall be carried out under the supervision of professionals familiar with the operation of flammable refrigerants. Any personnel who carry out maintenance or inspection on components related to the system or equipment must meet the requirements of EN 13313 and possess the corresponding qualifications. Personnel operating refrigeration systems with flammable refrigerants must hold relevant training certificates and possess the ability to safely handle flammable refrigerants.

R290 pressure-temperature gauge

Absolute pressure	Saturation temperature	Absolute pressure	Saturation temperature	Absolute pressure	Saturation temperature	Absolute pressure	Saturation temperature
0.10	-42.41	1.10	30.79	2.10	59.61	3.10	79.45
0.20	-25.45	1.20	34.38	2.20	61.88	3.20	81.15
0.30	-14.18	1.30	37.76	2.30	64.08	3.30	82.81
0.40	-5.47	1.40	40.96	2.40	66.20	3.40	84.43
0.50	1.73	1.50	43.99	2.50	68.26	3.50	86.01
0.60	7.92	1.60	46.88	2.60	70.26	3.60	87.55
0.70	13.40	1.70	49.64	2.70	72.20	3.70	89.05
0.80	18.32	1.80	52.29	2.80	74.09	3.80	90.52
0.90	22.81	1.90	54.82	2.90	75.92	3.90	91.96
1.00	26.94	2.00	57.26	3.00	77.71	4.00	93.37

7.1 Routine maintenance

This equipment must be maintained by qualified technicians. Before any operation on the system, relevant personnel must ensure that all safety precautions are available.

Improper or untimely equipment maintenance may lead to the deterioration of the performance of the unit components (heat exchangers, compressors, pipelines, etc.), which has a negative impact on the operational efficiency and functionality of the equipment.

Maintenance task is divided into two different levels and can be selected based on the application type (critical/non-critical) or installation environment (highly corrosive). Critical applications such as process cooling, data centers, etc., are defined as high-corrosion environments as follows:

- ① Industrial environment (where smoke accumulation from combustion and chemical processes may occur);
- ② Coastal environment;
- ③ Highly polluted urban environment;
- ④ Rural environments close to animal excrement and chemical fertilizers, as well as highly concentrated exhaust emissions from diesel generators;
- ⑤ Desert areas with the risk of sandstorms;
- ⑥ Combination of the above-mentioned environments.

Table 7 gives all maintenance items under standard applications and standard environments.

Table 8 gives all maintenance items for critical applications or highly corrosive environments.

The corrosion rate of units exposed to highly corrosive environments may be much faster than that of units in standard environments. Corrosion will cause the core of the frame to rust rapidly, thereby shortening the service life of the unit structure. To avoid such problems, it is necessary to regularly rinse the frame surface with clean water and appropriate cleaning agents.

If the coating on the unit frame peels off, special repair materials must be used to re-spray the exposed areas to prevent the corrosion from continuing to spread. Please contact the factory to obtain the specific specification information of the required products.

If only salt deposits are present, thoroughly rinse the relevant area with clean water.

7.2 Maintenance of air-side heat exchangers

Regular cleaning of the surface of the air heat exchanger is crucial for maintaining the normal running of the unit and preventing corrosion & rust. Removing contaminants and harmful residues may significantly extend the service life of the coil and enhance the overall lifespan of the unit.

As part of the daily maintenance and upkeep, it is recommended to follow the steps below for cleaning and maintenance:

Use a vacuum cleaner (it is recommended to use flexible accessories such as soft brushes and avoid using metal tubes), compressed air blown from the inside out, and/or soft bristles (metal wire brushes are prohibited) to remove surface dust, fallen leaves, fibers and other debris;

When operating, do not strike or scrape the surface of the fins with tools such as vacuum tubes or air nozzles.

NOTE

For fins applied in coastal or industrial environments, it is recommended to rinse them with clean water once a month to help remove chlorides, fouling and debris. When rinsing, make sure the water temperature is below 55°C. Raising the water temperature appropriately (but not exceeding 55°C) may reduce the surface tension of water and enhance the ability to remove chlorides and fouling.

7.3 Removing scale

After long-term running, the heat transfer surface of the water-side heat exchanger will deposit calcium oxide or other minerals. When the heat transfer surface is excessively fouled, these substances will affect the heat transfer performance and lead to problems such as increased power consumption and excessively high exhaust pressure (or excessively low suction pressure).

Organic acids such as formic acid, citric acid and acetic acid can be used for descaling and cleaning. However, it shall be particularly noted that since the water-side heat exchanger is made of stainless steel and is prone to corrosion, which may cause refrigerant leakage, the use of cleaning agents containing fluoroacetic acid or fluorides is strictly prohibited. The following precautions shall be observed during the cleaning and descaling process:

Professional operation requirements: The cleaning of water-side heat exchangers shall be carried out by professionals. It is recommended to contact local service providers for handling.

NOTE

Post-cleaning treatment:

- After using the cleaning agent, the pipes and heat exchangers must be thoroughly rinsed with clean water.
- Treat the water system to prevent corrosion or secondary adsorption of scale in the system.

NOTE

Cleaning parameter control:

- Adjust the concentration of the cleaning agent, the duration of operation and the temperature according to the degree of scaling.
- The waste liquid must be neutralized after the pickling process is completed.
- The treated waste liquid shall be handed over to a professional company for disposal.

NOTE

Operators must wear full protective gear (goggles, gloves, gas masks and protective shoes) to avoid inhaling or coming into contact with corrosive cleaning agents and neutralizers, and prevent damage to the eyes, skin and nasal mucosa.

7.4 Anti-freeze protection

The system anti-freezing design takes into account the following methods:

Ensure a continuous water circulation within the pipes and heat exchangers;

Additional heating measures shall be implemented for exposed pipelines both inside and outside as well as along the line equipment;

Add an appropriate amount of ethylene glycol to the water circuit;

If the unit is shut down in winter and the environment temperature is below 0°C, the water circuit shall be cleaned and completely drained.

During the maintenance process, when the refrigerant is added to or discharged from the unit, the water-side heat exchanger may be at risk of freezing and cracking due to the sudden drop in refrigerant pressure. When the refrigerant pressure is lower than 0.4 MPa, there will always be a possibility of the pipeline freezing at any time. Therefore, it is necessary to maintain a continuous circulation of water inside the heat exchanger or completely drain the water inside.

WARNING

Installers and/or maintenance personnel are responsible for ensuring that the above-mentioned anti-freezing measures are taken. Full anti-freeze protection must always be maintained. Failure to follow the above operations may result in damage to the equipment and mass refrigerant leakage.

NOTE

Damage caused by freezing is not covered by the warranty, so anti-freezing measures must be taken. The electric heater needs to be selected and purchased separately.

7.4.1 Water flow switch anti-freezing

When the unit is shut down and powered off at environment temperatures below 2°C, the water flow switch inside the unit (as shown in the following figure) shall be removed first, and reinstalled after the remaining water is drained.

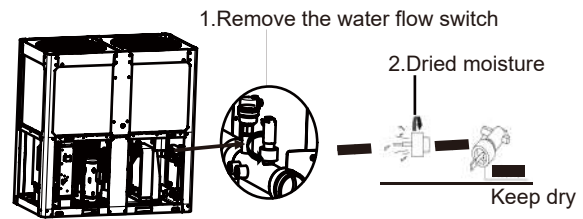

Fig. 7-1 Water flow switch drying diagram

7.5 Cooling system protection

When a system leak is detected or when components of the refrigeration system need to be replaced, an airtightness test must be conducted.

If a complete leakage occurs in the system, pressurized nitrogen shall be used for a comprehensive leak detection.

If welding repair is required, all gases in the system must be completely discharged before welding operations can be carried out.

Before charging the refrigerant, it is necessary to ensure that the entire cooling system is thoroughly dried and vacuumed; connect the vacuum pump tubing to the fluorine port on the low-pressure side and continue to evacuate for more than 3 hours.

Charge through the low-pressure side using a refrigerant cylinder, with the charging quantity based on the values indicated on the product nameplate and the main technical parameters table.

When replenishing the refrigerant, connect the low-pressure side fluorine nozzle to the refrigerant cylinder, install the low-pressure pressure monitoring instrument, and slowly inject the refrigerant.

NOTE

All operations must strictly comply with the equipment operation manual and safety regulations and must be carried out by authorized professionals.

CAUTION

After the refrigerant charging is completed, the connection parts must be re-tightened. When conducting leakage detection and airtightness tests, it is strictly prohibited to inject oxygen, acetylene or other flammable/toxic gases into the refrigeration system. Only pressurized nitrogen or designated refrigerants are allowed to be used.

7.6 Electrical maintenance

⚠ WARNING

All electrical maintenance tasks must be carried out by qualified personnel. Make sure the system is turned off and disconnect the main switch of the equipment; otherwise, it may cause serious personal injury. When the equipment is turned off but the switch in the distribution box remains closed, the unused circuits will still be live.

The maintenance of the electrical system shall follow the following general rules: the actual operating current of the compressor shall be compared with the rated value. Under normal circumstances, the actual current value shall be lower than the rated value, which corresponds to the electric current of a fully loaded compressor under the maximum running conditions; a comprehensive safety inspection shall be conducted at least once every three months to verify the effectiveness of all safety functions.

As the service life of all equipment increases, its running parameters may change. It is necessary to adjust or replace the equipment in a timely manner through monitoring.

7.7 Maintenance of sealed electric control box

As R290 refrigerant is flammable and explosive, the sealed electric control box of this unit can effectively reduce the risk. When maintaining the electric control box, the following points shall be noted:

After the maintenance of the electric control box cover, it needs to be reinstalled.

After the power cord is connected to the inlet, each rubber grommet through which the wire passes shall be tightly fastened with zip ties.

All cable grommets that had their original zip ties removed during maintenance must be re-secured in the same position with new zip ties after servicing.

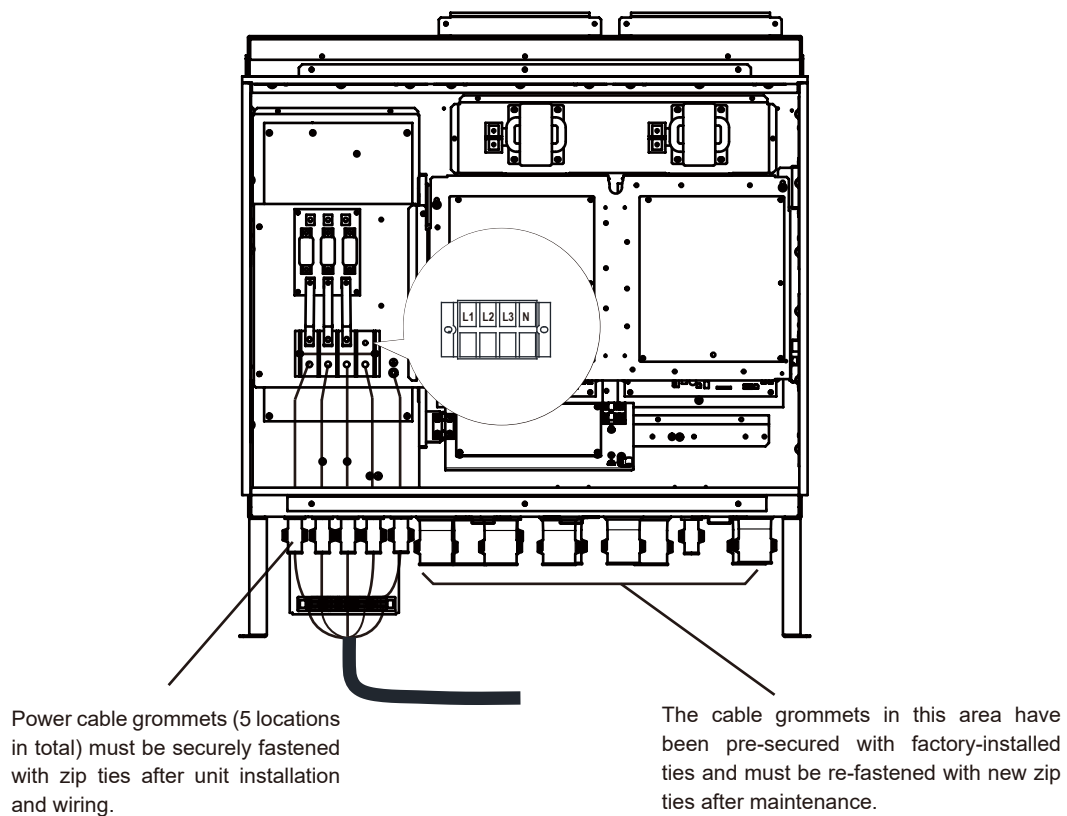

Fig. 7.2

7.8 Service and warranty period

The warranty period for the whole unit is within 30 months after leaving the factory, or within 24 months after product commissioning and acceptance (whichever comes first).

This equipment is strictly developed and manufactured in accordance with high standards, assuring long-term trouble-free running. However, even during the warranty period, maintenance is still required from the date of equipment installation (rather than just from the date of commissioning). To assure efficient and worry-free service, we strongly recommend that you sign a maintenance contract with an authorized service provider by the manufacturer, and rely on the expertise and experience of professionals to guarantee the running of your equipment.

Please note that improper operation, overrunning the running limits or failure to perform regular maintenance as required by this Manual may result in the invalidation of the warranty.

It is recommended that you contact a local service provider for inspection and maintenance of the unit before each cooling and heating season every year.

NOTE

Please observe the following points to assure compliance with the warranty terms:

This equipment shall not run outside the specified range;

The power supply voltage must be within the specified limits and free of voltage harmonics or sudden changes;

The equipment must remain off until the power issue is addressed;

No mechanical, electrical or electronic safety device shall be disabled or bypassed;

The water injection for the water circulation system must use clean and properly treated water, and a mechanical filter shall be installed as close as possible to the inlet of the plate heat exchanger.

Table 7-1 Standard Routine Maintenance Plan

List of Activities	Weekly	Monthly	Annual/Seasonal
General			
Check whether there is any damage or looseness in the unit.		×	
Check for the integrity of insulation.			×
Clean and paint as necessary.			×
Water quality analysis			×
Electrical equipment installation			
Check whether all electrical terminal connections are tight.			×
Clean the interior of the electric control box.			×
Check for any signs of overheating in the components.		×	
Check for the working conditions of the compressor and the electric heater.		×	
Use a multimeter to measure the insulation of the compressor motor.			×
Refrigerant circuit			
Check for refrigerant leakage		×	
Analyze the compressor's vibration			×
Check the safety valve (Note 1)		×	
Hydraulic circuit			
Check for any water leakage		×	
Check for water circuit connections		×	
Check for the inlet pressure of the pump		×	
Clean the water filter			×
Check for the concentration of ethylene glycol (if any)			×
Check for the water flow rate.		×	
Check the safety valve			×
Finned heat exchanger			
Check for the cleanliness of the fins (Note 2)			×
Check whether the fan is securely fastened			×
Plate heat exchanger			
Check for the cleanliness of the plate heat exchanger			×

1. Check if the lid and seal have been damaged; check whether the drain connection of the safety valve is blocked by foreign objects or rusted; check the validity period of the safety valve and replace it in accordance with current national laws if necessary.
2. Clean the finned heat exchanger with clean water and clean the plate heat exchanger with appropriate chemicals. Particles and fibers may clog heat exchangers, especially for water heat exchangers. Special attention shall be paid when using water rich in calcium carbonate. An increase in pressure drop or a decrease in thermal efficiency indicates that the heat exchanger is clogged. In environments with a higher concentration of particulate matter in the air, it may be necessary to clean the finned heat exchanger more frequently.
3. Even if it is not running for a long time, regular maintenance is still required when it is placed or stored in a highly corrosive environment.

Table 7-2 Routine Maintenance Plan for Critical Application and/or Highly Aggressive Environment

List of Activities (Note 8)	Weekly	Monthly	Annual/Seasonal
General			
Check whether there is any damage or looseness in the unit.		x	
Check for the integrity of insulation.			x
Clean and paint as necessary.			x
Water quality analysis			x
Electrical equipment installation			
Check whether all electrical terminal connections are tight.			x
Clean the interior of the electric control box.		x	
Check for any signs of overheating in the components.		x	
Check for the working conditions of the compressor and the electric heater.		x	
Use a multimeter to measure the insulation of the compressor motor.			x
Refrigerant circuit			
Check for refrigerant leakage		x	
Analyze the compressor's vibration			x
Check the safety valve (Note 1)		x	
Hydraulic circuit			
Check for any water leakage		x	
Check for water circuit connections		x	
Check for the inlet pressure of the pump		x	
Clean the water filter			x
Check for the concentration of ethylene glycol (if any)			x
Check for the water flow rate.		x	
Check the safety valve			x
Finned heat exchanger			
Check for the cleanliness of the fins (Note 2)		x	
Check whether the fan is securely fastened			x
Plate heat exchanger			
Check for the cleanliness of the plate heat exchanger			x

7.9 Fault codes

Table 7-3

No.	Code	Content	Note
1	E0	Model mismatch fault	The capability selection is inconsistent with the actual model. Power on again after setting correctly
2	E1	Phase sequence error of main control board check	Recovered upon failure recovery
3	E2	Communication failure between master and the HMI or master and slave	Recovered upon failure recovery
	2E2	Communication failure between main control and extension board	Recovered upon failure recovery
	3E2	Communication failure between master and slave in a unit	Recovered upon failure recovery
4	E3	Total water outlet temperature sensor failure	Recovered upon failure recovery
5	E4	Unit water outlet temperature sensor failure	Recovered upon failure recovery
6	1E5	Condenser tube temperature sensor T3A failure	Recovered upon failure recovery
7	E6	Water tank temperature sensor T5 failure	Recovered upon failure recovery
8	E7	Ambient temperature sensor failure	Recovered upon failure recovery
9	E8	Power supply phase sequence protector output error	Recovered upon failure recovery
10	E9	Water flow detection failure	Failure locking for 3 times in 60 minutes (Recovered by power off or Wired controller clear fault)
11	1Eb	Taf1 the pipe of the tank antifreeze protection sensor failure	Recovered upon failure recovery
12	2EB	Taf2 cooling evaporator low-temperature antifreeze protection sensor failure	Recovered upon failure recovery
13	Ed	System discharge temperature sensor failure	Recovered upon failure recovery
14	1EE	EVI plate heat exchanger refrigerant temperature T6A sensor failure	Recovered upon failure recovery
	2EE	EVI plate heat exchanger refrigerant temperature T6B sensor failure	Recovered upon failure recovery
15	EF	Unit water return temperature sensor failure	Recovered upon failure recovery
16	EP	Discharge sensor failure alarm	Recovered upon failure recovery
17	EU	Tz sensor failure	Recovered upon failure recovery
18	P0	System high-pressure protection or discharge temperature protection	for 3 times in 60 minutes (Recovered by power off)
	1P0	System high-pressure switch disconnect protection	Recovered upon failure recovery
19	P1	System low pressure protection (or Severe refrigerant leakage protection)	for 3 times in 60 minutes (Recovered by power off)
20	P3	T4 ambient temperature too high in cooling mode	Recovered upon failure recovery
21	1P4	System A current protection	for 3 times in 60 minutes (Recovered by power off)
	2P4	System A DC bus current protection	(Recovered by power off)
22	P6	Inverter module failure	Recovered upon error recovery
23	P7	High temperature protection of system condenser	for 3 times in 60 minutes (Recovered by power off)
24	P9	Water inlet and outlet temperature difference protection	Recovered upon failure recovery
25	PA	Abnormal water inlet and outlet temperature difference protection	Recovered upon failure recovery
26	PC	Cooling evaporator pressure too low	Recovered upon error recovery
27	PE	Cooling evaporator low temperature antifreeze protection	Recovered upon error recovery
28	PH	Heating T4 too high temperature protection	Recovered upon error recovery
29	PL	Tfin module temperature too high protection	for 3 times in 100 minutes (Recovered by power off)
	1PU	DC fan A module protection	Recovered upon failure recovery
30	1bh	Module 1 failure	Recovered upon error recovery

No.	Code	Content	Note
31	H5	Voltage too high or too low	Recovered upon error recovery
32	1H9	Compressor inverter module is not matched	Recovered upon error recovery
33	HC	High pressure sensor failure	Recovered upon error recovery
34	1HE	No inset A valve error	Recovered upon error recovery
	2HE	No inset B valve error	Recovered upon error recovery
	3HE	No inset C valve error	Recovered upon error recovery
35	1F0	IPM module A transmission error	Recovered upon error recovery
36	F2	Superheat insufficient	Wait at least 20min before recovering
37	F4	1F4 module 1L0 or 1LE protection occurs for 3 times in 60 minutes	Recovered by power off
38	1F6	A system bus voltage error (PTC)	Recovered upon error recovery
39	Fb	Low pressure sensor error	Recovered upon error recovery
40	Fd	Suction temperature sensor error	Recovered upon error recovery
41	1FF	DC fan A error	Recovered by power off
42	FP	DIP switch inconsistency of multiple water pumps	Recovered by power off
43	1L10	Overcurrent protection	Overcurrent fault
	1L11	Transient phase current overcurrent protection	
	1L12	Phase current overcurrent lasts 30s protection	
44	1L20	Module over temperature protection	Over temperature fault
45	1L31	Low bus voltage error	Power fault
	1L32	High bus voltage error	
	1L33	Excessively high bus voltage error	
	1L34	Phase loss error	
46	1L43	Phase current sampling bias abnormal	hardware fault
	1L45	Motor code not match	
	1L46	IPM protection	
	1L47	Module type not match	
47	1L50	Startup failure	Control fault
	1L51	Out of step error	
	1L52	Zero speed error	
48	1L60	Fan motor phase loss protection	Diagnostic fault
	1L65	IPM short circuit error	
	1L66	FCT detection error	
	1L6A	Open circuit of U-phase upper tube	
	1L6B	Open circuit of U-phase lower tube	
	1L6C	Open circuit of V-phase upper tube	
	1L6D	Open circuit of V-phase lower tube	
	1L6E	Open circuit of W-phase upper tube	
1L6F	Open circuit of W-phase lower tube		

8 FIRST STARTUP CHECK

WARNING

The first startup of the unit must be carried out by an authorized person.

8.1 Precautions before first startup:

- 1) After multiple rounds of flushing and blowdown at the water system pipelines, it is confirmed that the water quality cleanliness is conforming; after refilling and emptying the system again, the water pump will be started to confirm that the water flow rate and outlet pressure are conforming. Note that the pipes shall be cleaned separately through the bypass pipe and bypass valve of the unit. Do not connect the unit for flushing together to avoid flushing any foreign objects into or to the water side heat exchanger.
- 2) The settings of the wired controller shall be made in accordance with the instructions of the remote control manual. Under normal circumstances, during the trial run, various parameters shall be set to run near the standard working conditions, and it is advisable to avoid setting them at the extreme working conditions of the unit.
- 3) The trial run can be carried out only after confirming that all valves are open.
- 4) The trial run can be carried out only after the electrical safety inspection is completed.
- 5) Forced operation is absolutely prohibited (the protective device will not act, which is extremely dangerous).
- 6) The trial run and commissioning of the hot water floor radiant heating system shall be carried out after the completion of construction and the expiration of the curing period, and under the condition that normal heating, cooling and power supply are available.

Pre-startup inspection checklist for the unit:

Inspection Item	Item description	Item acceptance methods and specification requirements	YES	NO
Installation and acceptance of the unit	Check whether the appearance integrity of the unit is conforming.	Check for no dents, scratches, or bent fins, etc.		
	Check whether the accompanying accessories are complete.	For details, please refer to the content of the attached manual.		
	Check whether the integrity of the internal systems and components of the unit is conforming.	Check for no pipeline collision, component loosening or leakage, etc.		
	Check whether the three-dimensional space of the installed unit is conforming.	For detailed installation space requirements of the unit, please refer to the Manual.		
	Check whether the installation foundation height of the unit is conforming.	NLT 200 mm; NLT 500 mm in a cold area		
	Check whether the vibration isolation measures for the generator set and the water pump are conforming.	Check that standard vibration damping parts or vibration damping springs have already been installed.		
	Check whether the unit is installed on a solid foundation and leveled as required.	Check that the fixing bolts are tightened and the level is adjusted with a level instrument.		
	Check whether the air inlet and outlet spaces of the air side heat exchanger are conforming.	Check for unobstructed air circulation around the heat exchanger and no objects blocking it.		
	Check whether the equipment is protected from direct sunlight and whether the water pump is rainproof as required.	Confirm that there is no direct sunlight on the sensor and that the water pump already has rain protection measures.		
	Check whether the space for after-sales maintenance, servicing and repair work is conforming.	Check the surrounding sheet metal of the unit for easy removal and the electric control box for sufficient serving space.		
	Check whether the snow prevention measures of the unit are conforming.	The height of the base shall be more than 200mm higher than the maximum snowfall height in the area. Regular snow and ice removal shall be carried out to assure the normal running of the unit.		
	Check whether the noise from the unit has any impact on the surrounding environment and whether there is any resonance from the unit that affects the buildings.	Implement noise reduction and resonance avoidance measures for noise-sensitive areas.		

Inspection Item	Item description	Item acceptance methods and specification requirements	YES	NO
Check for installation and acceptance of water systems	Check the installation of the entire water system and the integrity of the water tank's appearance to assure conformity.	Refer to the water system diagram in the Manual.		
	On-site verification is carried out to check whether the head and flow rate of the water pump meet the design requirements.	Calculate the pump head and total flow rate of the entire engineering system.		
	check whether the head and flow rate of the water pump meet the design requirements.	Check whether the make-up water control of the water system complies with the design requirements.		
	Check whether the water quality of the water system meets the design requirements.	Refer to the water quality requirements in the Manual.		
	Check whether the pipe specifications of single and multiple units are conforming.	For detailed requirements on pipe diameters, please refer to the Manual.		
	Check whether the cleaning at the end and the tight pressure retention are conforming.	Ensure that the end and the unit are disconnected for pressure maintenance and cleaning, and control the water pressure value.		
	Check whether the cleaning and tight pressure holding of the water system pipelines are conforming.	For the acceptance criteria of pressure holding, sealing and cleaning, please refer to the relevant specifications in the Manual.		
	Check whether the support and thermal expansion and contraction measures of the water system pipeline are conforming.	Check the fixed supports and expansion of steel pipes and PPR pipes of different diameters.		
	Check whether the measures for draining the highest points of the water system and the high points of the branch lines are conforming.	Check for the position and quantity of exhaust valves configured at branch circuits and the highest points.		
	Check whether the drainage measures at the lowest points of the water system and the low points of the branch lines are conforming.	Check the branch and lowest point drainage function.		
	Check whether the insulation of the pipelines, water tanks and valve fittings in the entire water system is conforming.	Check for the thickness and adhesion quality of the insulation cotton, as well as the fixation of the protective layer.		
	Check whether the installation of the filtration and descaling devices in the water system is conforming.	Check for the flow direction of the filter, the mesh size of the filter screen and the technical requirements.		
	Check whether the installation of the total outlet water temperature sensor for the entire water system is conforming.	For detailed installation requirements of the total outlet water temperature sensor, please refer to the Manual.		
	Ethylene glycol percentage (if any)	Confirm the percentage of ethylene glycol		
	Check whether all isolation valves (or stop valves) are open.	Confirm whether to open.		
	Water circuit cleaning	Assure water quality		
Filter cleaning	Make sure the filter is clean.			
Electrical installation and wiring acceptance	Check whether the integrity of the circuits and electrical components inside the electronic control box is conforming.	Check whether the electrical components, connection plugs and terminals are loose.		
	Check whether the integrity of the internal circuits and protective devices of the unit is conforming.	Check the zip ties, ensuring the fasteners are secure, and verify if the sensors are disconnected, etc.		

Inspection Item	Item description	Item acceptance methods and specification requirements	YES	NO
Electrical installation and wiring acceptance	Check whether the power supply voltage and frequency of the unit meet the design requirements.	The main power supply voltage value is within the range of 380V ± 10%, and the frequency is 50Hz.		
	Check whether the power phase sequence wiring and wire specifications meet the design requirements.	For details, please refer to the specifications of wire diameter and the inspection of phase sequence connection in the Manual.		
	Check whether the specifications of the protection switch in the system meet the design requirements.	For detailed technical requirements of the protection switch, please refer to the Manual.		
	Check whether the wiring of the low-voltage lines that need to be externally connected inside the electric control box is conforming.	Check that the labels of the access lines correspond to those of the terminal blocks and ensure that the terminals are locked.		
	Check that the control of the water pump and the interlocking control of the unit meet the design requirements.	On-site simulation of the interlocking trial run and acceptance of the water pump and the unit.		
	Check whether the connection between the wired controller and the unit and the power supply meet the design requirements.	Check for the correct wiring of the three-core communication line and the shielding layer of the wired controller, as well as the power supply requirements.		
	Check whether the DIP switch settings of the master and slave units are correct when multiple units are installed.	Pay attention to the DIP switch settings of the main and slave units.		
	On-site, it is ultimately confirmed whether the locking of each terminal block meets the design requirements.	Confirm that all cables and terminal blocks are securely fastened before the trial run.		
	Check whether the grounding of the power supply source, the unit and the internal grounding of the electric control box meet the design requirements.	Check for the effectiveness of the grounding measures with a multimeter.		
Check whether the lightning protection network on the site of the unit meets the design requirements.	Check for the lightning protection measures and the lightning protection network system connected to the building.			

8.2 Commissioning

Turn on the controller and check if there are any fault codes displayed on the unit. In case of any fault, eliminate the fault first. After confirming that there is no fault with the unit, start the unit according to the operation method set forth in the user manual of wired controller.

Run the system for 30 minutes on trial. When the inlet and outlet water temperatures stabilize, adjust the water flow rate to meet the requirements of the unit and assure its normal run.

After the machine stops, wait for 10 minutes before restarting it to avoid frequent starts of the unit.

9 LOOP CIRCUIT

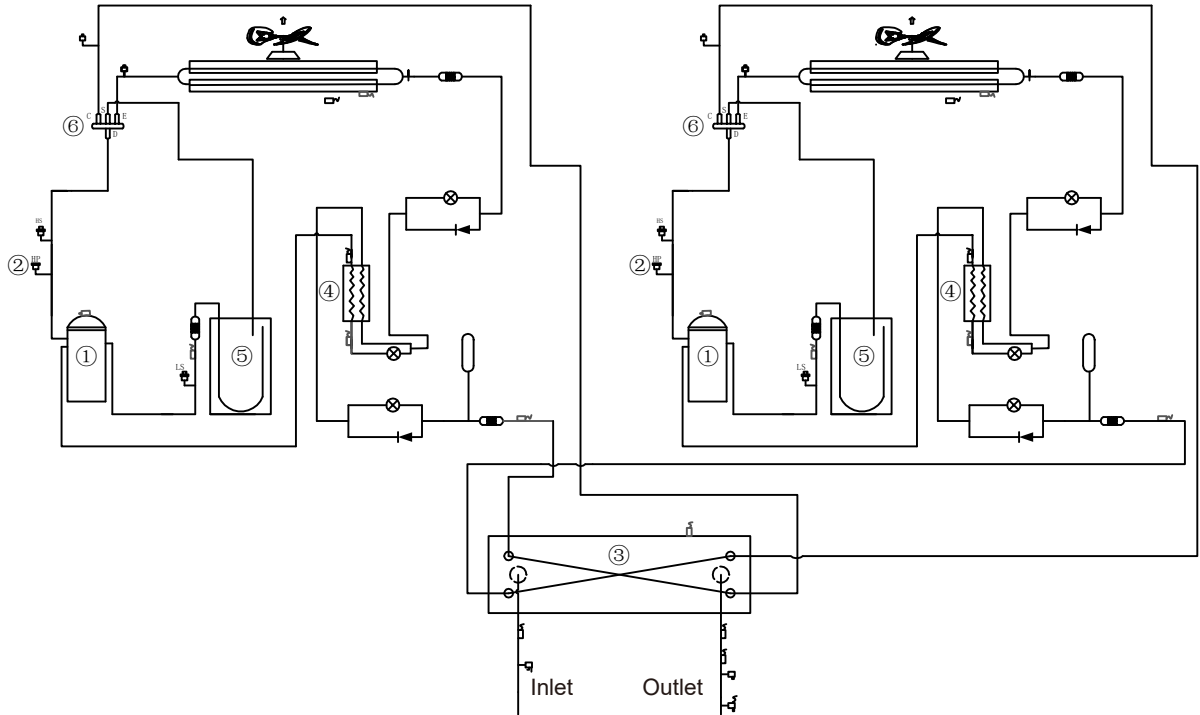

① Compressor	② Four-way Valve	③ fan
④ Economizer	⑤ Plate Heat Exchanger	

10 REFRIGERANT CHARGE INFORMATION

This product contains R290 refrigerant with a GWP value of 3. The refrigerant charging information for the product is shown as below in the figure.

	Factory charge		Field charge	
System1=	2.8	+	0	kg
System1=	2.8	+	0	kg
System1+System2=	5.6	+	0	kg
Total refrigerant charge Factory+Field	5.6			kg
GWP x kg/1000	0.0168			tCO ₂ eq

11 REGULAR INSPECTION AND ADJUSTMENT OF PRESSURE EQUIPMENT

These equipment fall into Categories III and IV as defined by the European Directive 2014/68/EU (PED). For equipment in these categories, some local regulations require regular inspections by authorized personnel. Please verify with the requirements of your location.

12 DECOMMISSIONING AND DISPOSAL

This equipment is composed of metal, plastic and electronic components. All these components must be disposed of in accordance with local disposal regulations. If they fall within the scope of national laws implementing Directive 2012/19/EU (RAEE), they must be disposed of in accordance with these laws. Lead-acid batteries must be collected and sent to specific waste collection centers. Select appropriate pressure vessels and tools for transferring fluids under pressure to prevent refrigerant gas from escaping into the environment. This operation must be carried out by qualified personnel in the field of cooling systems and in compliance with the current laws of the country where the installation is taking place.

13 SERVICE LIFE

The service life of this equipment is 10 years. Thereafter, the manufacturer recommends a comprehensive control of the entire system, and especially an integrity check of the pressurized refrigerant circuit, which is a requirement of the current laws in some European Community countries.

14 TECHNOLOGY DATA

For detailed technical parameters of the equipment, please refer to the technical manual.

Model	3-phase	3-phase	3-phase
	50 kW	60 kW	70 kW
Nominal capacity	Refer to the Technical Data		
Dimensions H×W×D	2 000 mm x 960 mm x 1 870 mm		
Packing dimensions H×W×D	2 085 mm x 1 030 mm x 2 050 mm		
Weight			
Net weight	615kg		
Gross weight	640kg		
Connections			
Specifications of water pipe	DN 50		
Pipe connection	Hoop connection		
Water side heat exchanger			
Water pressure drop	60 kPa		
Operating Maximum pressure	2 100 kPa		

Operation range - water side	
Heating	+25 to +85 °C
Cooling	-5 to +25 °C
Operation range - air side	
Heating	-25 to 43 °C
Cooling	-15 to 48 °C
Domestic hot water by heat pump	-25 to 43 °C

Refrigerant	
Refrigerant type	R290
Refrigerant charge	5.6 kg (2.8 kg per system)

Fuse – on PCB		
PCB name	Main control board A/B	Expansion board
Model name	FUSE-T-5 A/250 VAC-T/S	FUSE-T-3.15 A/250 VAC-T-P
Working voltage (V)	250	250
Working current (A)	5	3.15

Fuse – on Electronic control box	
Model name	FUSE-T-100 A/690 VAC-T/S
Working voltage (V)	690
Working current (A)	100

16127100A13951 V.B



Kaysun
by **frigicoll**

MAIN OFFICE

Blasco de Garay, 4-6
08960 Sant Just Desvern
(Barcelona)
Tel. +34 93 480 33 22
<http://www.frigicoll.es/>
<http://www.kaysun.es/en/>

MADRID

Senda Galiana, 1
Polígono Industrial Coslada
Coslada (Madrid)
Tel. +34 91 669 97 01
Fax. +34 91 674 21 00
madrid@frigicoll.es