

OWNER'S & INSTALLATION MANUAL

Mini Amazon VRF (ODU)

KMF-80 DVR5

KMF-120 DVR5

KMF-160 DVR5

KMF-100 DVR5

KMF-140 DVR5

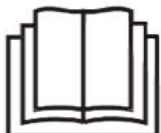

Original Instructions

Please read this manual carefully and keep it for future reference.
All the pictures in this manual are for illustration purpose only.

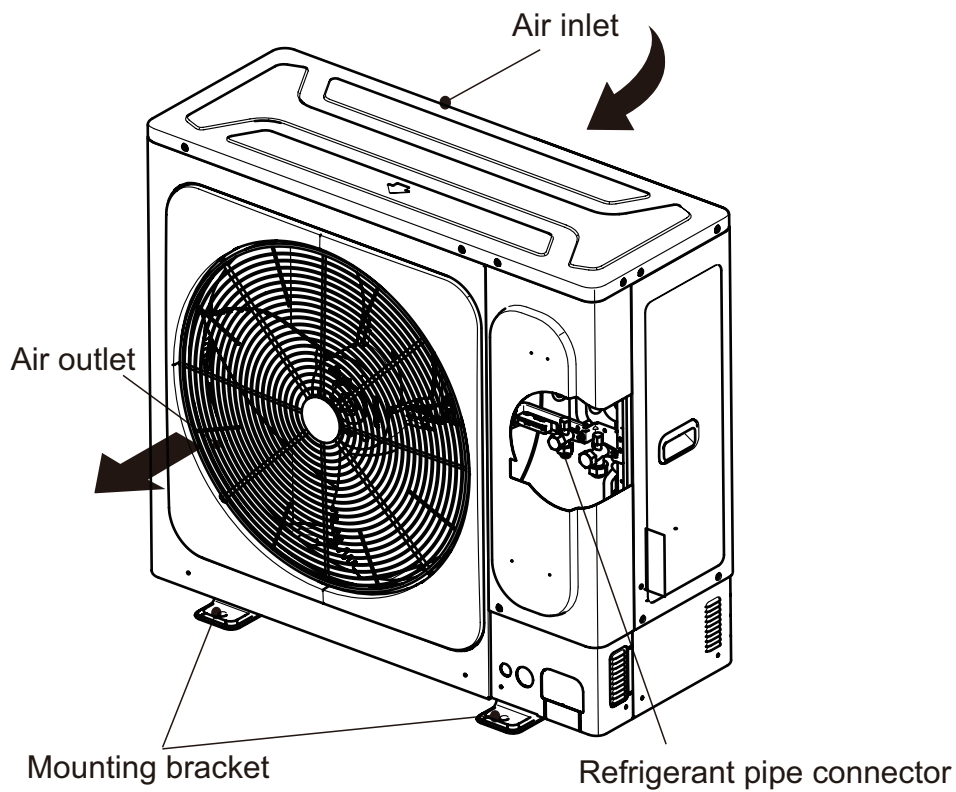

NOTE

- The figures in this manual are for explanation purposes only. They may be slightly different from the air conditioner you purchased (depending on the model). The actual shape shall prevail.
- The units comply with IEC 61000-3-12.

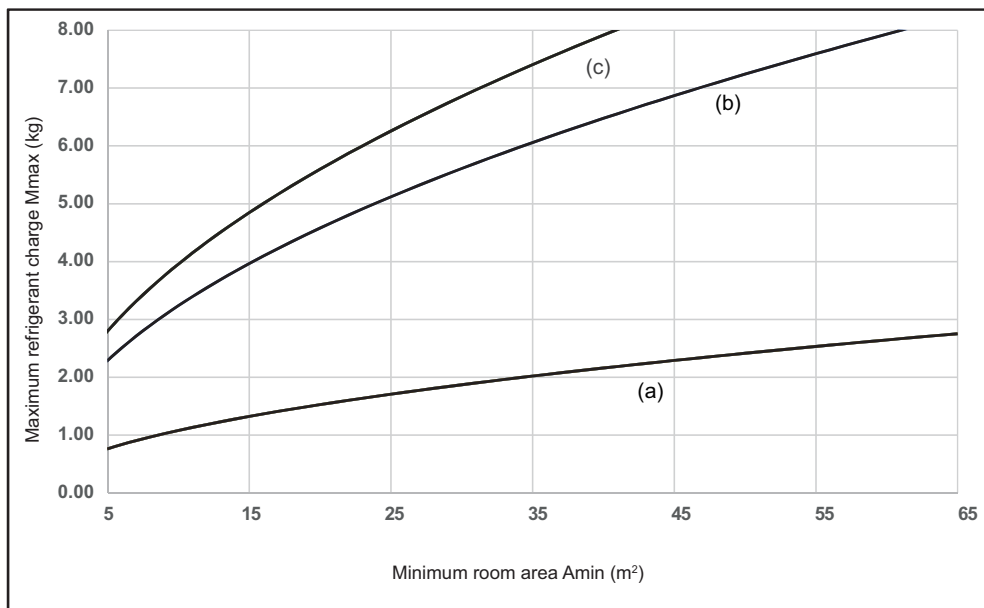

Curve (a) is the refrigerant charge limit for the IDU installation height $h \geq 0.6$ m
 Curve (b) is the refrigerant charge limit for the IDU installation height $1.8 \text{ m} \leq h < 2.2$ m
 Curve (c) is the refrigerant charge limit for the IDU installation height $h \geq 2.2$ m

Figure 1

Table 1

Amin(m ²)	Mmax(kg)--(a)/(b)/(c)	Amin(m ²)	Mmax(kg)--(a)/(b)/(c)	Amin(m ²)	Mmax(kg)--(a)/(b)/(c)
4	0.682/2.048/2.503	46	2.315/6.946/7.7	88	3.202/7.7/7.7
5	0.763/2.29/2.798	47	2.34/7.021/7.7	89	3.22/7.7/7.7
6	0.836/2.508/3.066	48	2.365/7.095/7.7	90	3.238/7.7/7.7
7	0.903/2.709/3.311	49	2.389/7.169/7.7	91	3.256/7.7/7.7
8	0.965/2.896/3.54	50	2.413/7.241/7.7	92	3.274/7.7/7.7
9	1.024/3.072/3.755	51	2.437/7.313/7.7	93	3.292/7.7/7.7
10	1.079/3.238/3.958	52	2.461/7.385/7.7	94	3.309/7.7/7.7
11	1.132/3.396/4.151	53	2.485/7.455/7.7	95	3.327/7.7/7.7
12	1.182/3.547/4.336	54	2.508/7.525/7.7	96	3.344/7.7/7.7
13	1.23/3.692/4.513	55	2.531/7.595/7.7	97	3.362/7.7/7.7
14	1.277/3.832/4.683	56	2.554/7.664/7.7	98	3.379/7.7/7.7
15	1.322/3.966/4.847	57	2.577/7.7/7.7	99	3.396/7.7/7.7
16	1.365/4.096/5.006	58	2.599/7.7/7.7	100	3.413/7.7/7.7
17	1.407/4.222/5.161	59	2.622/7.7/7.7	105	3.498/7.7/7.7
18	1.448/4.345/5.31	60	2.644/7.7/7.7	110	3.58/7.7/7.7
19	1.488/4.464/5.456	61	2.666/7.7/7.7	115	3.66/7.7/7.7
20	1.526/4.58/5.597	62	2.688/7.7/7.7	120	3.739/7.7/7.7
21	1.564/4.693/5.736	63	2.709/7.7/7.7	125	3.816/7.7/7.7
22	1.601/4.803/5.871	64	2.731/7.7/7.7	130	3.892/7.7/7.7
23	1.637/4.911/6.003	65	2.752/7.7/7.7	135	3.966/7.7/7.7
24	1.672/5.017/6.132	66	2.773/7.7/7.7	140	4.039/7.7/7.7
25	1.706/5.12/6.258	67	2.794/7.7/7.7	145	4.11/7.7/7.7
26	1.74/5.222/6.382	68	2.815/7.7/7.7	150	4.181/7.7/7.7
27	1.773/5.321/6.504	69	2.835/7.7/7.7	155	4.25/7.7/7.7
28	1.806/5.419/6.623	70	2.856/7.7/7.7	160	4.318/7.7/7.7
29	1.838/5.515/6.74	71	2.876/7.7/7.7	165	4.385/7.7/7.7
30	1.869/5.609/6.856	72	2.896/7.7/7.7	170	4.451/7.7/7.7
31	1.9/5.702/6.969	73	2.916/7.7/7.7	175	4.516/7.7/7.7
32	1.931/5.793/7.08	74	2.936/7.7/7.7	180	4.58/7.7/7.7
33	1.961/5.883/7.19	75	2.956/7.7/7.7	185	4.643/7.7/7.7
34	1.99/5.971/7.298	76	2.976/7.7/7.7	190	4.705/7.7/7.7
35	2.019/6.058/7.405	77	2.995/7.7/7.7	195	4.767/7.7/7.7
36	2.048/6.144/7.51	78	3.015/7.7/7.7	200	4.827/7.7/7.7
37	2.076/6.229/7.614	79	3.034/7.7/7.7	250	5.397/7.7/7.7
38	2.104/6.313/7.7	80	3.053/7.7/7.7	300	5.912/7.7/7.7
39	2.131/6.395/7.7	81	3.072/7.7/7.7	350	6.386/7.7/7.7
40	2.159/6.477/7.7	82	3.091/7.7/7.7	400	6.827/7.7/7.7
41	2.185/6.557/7.7	83	3.11/7.7/7.7	450	7.241/7.7/7.7
42	2.212/6.637/7.7	84	3.128/7.7/7.7	500	7.633/7.7/7.7
43	2.238/6.715/7.7	85	3.147/7.7/7.7	505	7.671/7.7/7.7
44	2.264/6.793/7.7	86	3.165/7.7/7.7		
45	2.29/6.87/7.7	87	3.184/7.7/7.7		

CONTENTS

1 About the Documentation	1
2 Safety Signs	1
• 2.1 Explanation of Safety Signs.....	1
• 2.2 Explanation of Symbols Displayed on the Unit.....	1
• 2.3 About the Refrigerant	1
Operation Manual	
3 Important Information for User	4
4 System Information	8
• 4.1 System Layout.....	8
5 Operating Instructions	9
• 5.1 Operating Range	9
• 5.2 Operating System.....	9
• 5.3 Dry Program	10
• 5.4 Cutting off Power Supply	10
• 5.5 Protection Procedure.....	10
6 Maintenance and Repair	11
• 6.1 About Refrigerant	11
• 6.2 After-sales Service and Warranty.....	11
7. Troubleshooting	12
• 7.1 Air Conditioner Problems and Causes	12
• 7.2 Remote Controller Problems and Causes	12
• 7.3 Fault Symptom: Non Air Conditioning Issues	14
8 Relocation	14
9 Disposal	14
Installation Manual	
10 Precautions	14
11. Packing Box	16
• 11.1 Overview.....	16
• 11.2 Transportation	16
• 11.3 Unpacking the ODU.....	16
• 11.4 Attached Fittings.....	17
12 ODU Combination Ratio	17
13 Unit Installation	18
• 13.1 Choosing and Preparing the Installation Site	18
• 13.2 Opening and Closing the Unit.....	19
• 13.3 ODU Installation	20

14 Installation of Refrigerant Piping	21
• 14.1 Selecting and Preparing the Refrigerant Piping	21
• 14.2 Connecting Refrigerant Piping.....	25
• 14.3 Checking Refrigerant Piping.....	27
15 Refrigerant Charging	29
• 15.1 Calculating Additional Refrigerant Charge.....	30
16 Electrical Wiring	31
• 16.1 Safety Device Requirements.....	31
• 16.2 Communication Wiring	33
• 16.3 Power Cable Connection.....	36
17 Configuration	37
• 17.1 Overview.....	37
• 17.2 Functions of SW1 and SW2 Buttons	37
• 17.3 S2 DIP Switch Function.....	37
• 17.4 Display Function.....	37
18 Commissioning	38
• 18.1 Overview.....	38
• 18.2 Things to Note During Test Run	38
• 18.3 Test Run Checklist.....	38
• 18.4 About Test Run.....	39
• 18.5 Starting Test Run	39
• 18.6 Rectifications after Test Run Is Completed.....	39
• 18.7 Operating the Unit	39
19 Troubleshooting	40
• 19.1 Error Code: Overview	40
• 19.2. Precautions for Refrigerant Leak.....	41
20 Specifications	42
• 20.1 Piping Diagram: ODU	42
21 ERP Information	46

1 About the Documentation

NOTE

- Make sure that the user has the printed documentation and ask him/her to keep it for future reference.

Target audience

Authorised installers + end users

NOTE

- This appliance is intended to be used by expert or trained users in shops, in light industry, and on farms, or for commercial and household use by lay persons.

WARNING

- Please thoroughly read and ensure that you fully understand the safety precautions (including the signs and symbols) in this manual, and follow relevant instructions during use to prevent damage to health or property.

Documentation set

This document is part of a documentation set. The complete set consists of:

- General safety precautions:
 - Safety instructions that you must read before installing
- Indoor unit installation and operation manual:
 - Installation and operation instructions
- Repeater installation and operation manual:
 - Installation and operation instructions

Technical engineering data

Latest revisions of the supplied documentation may be available via your dealer.

The original documentation is written in English. All other languages are translations.

2 Safety Signs

2.1 Explanation of Safety Signs

The precautions and things to note in this document involve very important information. Please read them carefully.

DANGER

Indicates a hazard with a high level of risk which, if not avoided, will result in serious injury.

WARNING

Indicates a hazard with a medium level of risk which, if not avoided, could result in serious injury.

CAUTION

Indicates a hazard with a low level of risk which, if not avoided, could result in minor or moderate injury.



NOTE

A situation that may cause damage to the equipment or loss of property.

INFORMATION

Indicates a useful hint or additional information.

2.2 Explanation of Symbols Displayed on the Unit

	<p>CAUTION</p> <p>This symbol indicates that the operation manual should be read carefully.</p>
	<p>CAUTION</p> <p>This symbol indicates that service personnel should be handling this equipment while referencing the installation manual.</p>
	<p>CAUTION</p> <p>This symbol indicates that additional information is available in documents such as the operating manual or installation manual.</p>

2.3 About the Refrigerant

WARNING

The application uses R32 refrigerant.



Caution: Risk of fire

(for IEC 60335-2-40: 2018 only)

WARNING

The application uses R32 refrigerant.



Caution: Risk of fire

(for IEC/EN 60335-2-40 except IEC 60335-2-40: 2018)

DANGER

These instructions are exclusively intended for qualified contractors and authorized installers.

- Work on the refrigerant circuit with flammable refrigerant in safety group A2L may only be carried out by authorized heating contractors. These heating contractors must be trained in accordance with EN 378 Part 4 or IEC 60335-2-40, Section HH. The certificate of competence from an industry accredited body is required.
- Brazing / soldering work on the refrigerant circuit may only be carried out by personnel certified in accordance with ISO 13585 and AD 2000, Datasheet HP 100R. And only contractors qualified and certified for the processes can perform brazing / soldering work. The work must fall within the range of applications purchased and be carried out in accordance with the prescribed procedures. Soldering / brazing work on accumulator connections requires certification of personnel and processes by a notified body according to the Pressure Equipment Directive (2014/68/EU).
- Work on electrical equipment may only be carried out by a qualified electrician.
- Before initial commissioning, all safety - related points must be checked by the particular certified heating contractors. The system must be commissioned by the system installer or a qualified person authorized by the installer.

WARNING

- Do not use means to accelerate the defrosting process or to clean, other than those recommended by the manufacturer.
- The appliance shall be stored in a room that does not have continuously operating ignition sources (for example: open flames, an operating gas appliance or an operating electric heater).
- Do not pierce or burn the unit.
- Be aware that refrigerants may be odorless.

WARNING

- Appliance shall be installed, operated and stored in a room that meets special requirements and has an area limit as shown in sections 2.3.2.

2.3.1 System Layout Requirements

2.3.1.1 Unit Installation Requirements

The outdoor unit shall be located in a well-ventilated location other than the occupied space, such as in the open air.

For installation of the indoor unit, refer to the corresponding installation and operation manual. If an indoor unit is installed in an unventilated area, the area shall be so constructed that should any refrigerant leak, it will not stagnate so as to create a fire or explosion hazard.

WARNING

- The appliance shall be stored in a well-ventilated area where the room size corresponds to the room area as specified for operation.
- The appliance shall be stored in a room that does not have continuously operating open flames (for example an operating gas appliance) and ignition sources (for example, an operating electric heater).

2.3.1.2 Piping Installation Requirements

Low temperature solder alloys, such as lead/tin alloys, are not acceptable for pipe connections.

Reusable mechanical connectors and flared joints are not allowed indoors. (EN 60335-2-40 Standard Requirements).

Mechanical connectors used indoors shall comply with ISO 14903. When mechanical connectors are reused indoors, sealing parts shall be renewed. When flared joints are reused indoors, the flaring part shall be re-fabricated.

Flexible refrigerant connectors (such as connecting lines between the indoor and outdoor unit) that may become displaced during normal operations shall be protected against mechanical damage. (IEC 60335-2-40 Standard Requirements).

The refrigerating systems shall use only permanent joints indoors except for site-made joints directly connecting the indoor unit to the refrigerant piping, or factory made mechanical joints in compliance with ISO 14903. (IEC 60335-2-40 Standard Requirements).

Equipment pipes in the occupied space in question must be installed in such a way that it is protected against accidental damage.

NOTE

- Installation of pipe-work shall be kept to a minimum.
- Pipework shall be protected from physical damage and shall not be installed in an unventilated space, if that space is smaller than Amin in Table 1.
- Compliance with national gas regulations shall be observed;
- Mechanical connections made shall be accessible for maintenance purposes.

2.3.2 Room Area Limitations

The system uses R32 refrigerant, which is classified as class A2 and is flammable under EN 60335-2-40. Follow the requirements below to ensure that the system complies with legislation.

The total amount of refrigerant in the system shall be less than or equal to the maximum refrigerant charge. The maximum refrigerant charge depends on the volume of space in the rooms being served by the system.

The room area (A) shall be defined as the room area enclosed by the projection to the base of the walls, partitions and doors of the space in which the appliance is installed.

⚠ WARNING

- The space considered shall be any space which contains refrigerant-containing parts or into which refrigerant could be released.
- The room area (A) of the smallest, enclosed, occupied space shall be used in the determination of the refrigerant quantity limits.

■ Installation scheme flow chart

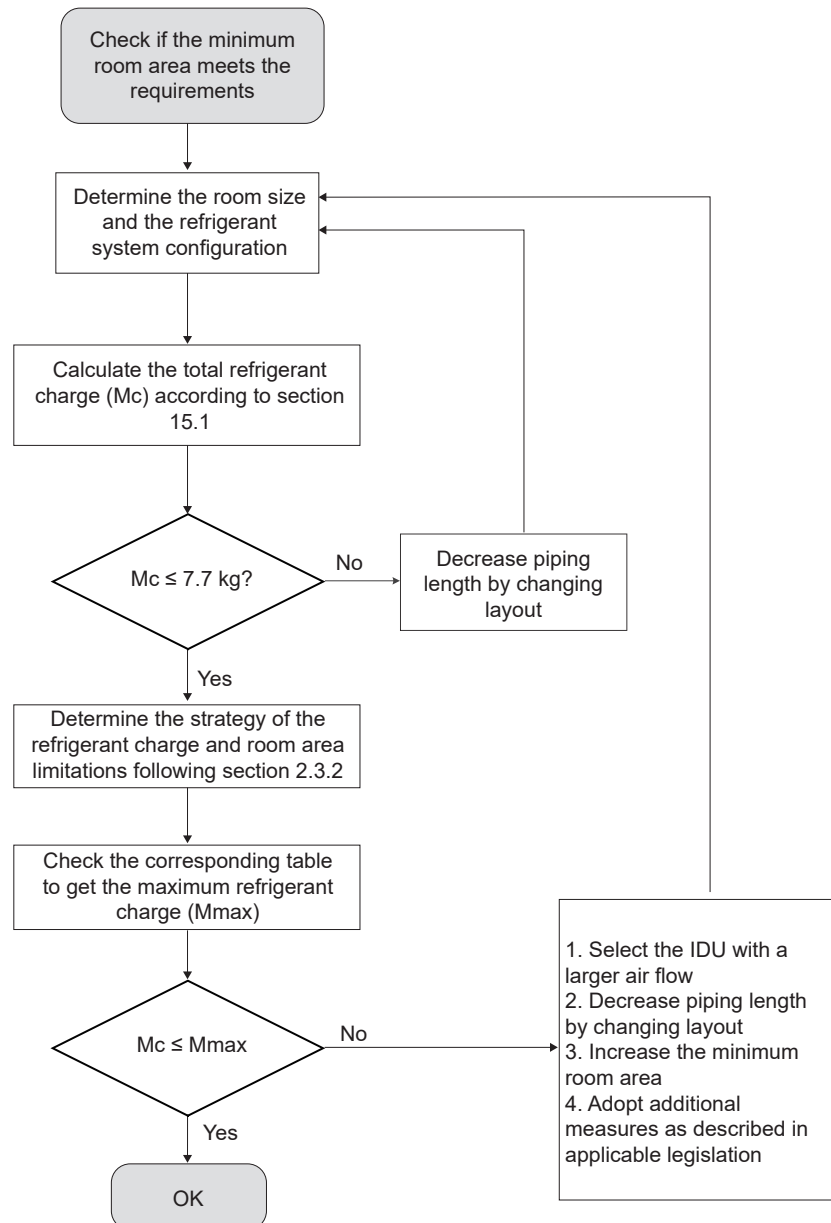

In addition, the maximum refrigerant charge is also related to the installation height of the DHW kit and hydraulic module of the IDU. The correspondence of the maximum refrigerant charge with the minimum room area (A_{min}) is shown in Figure 1 and Table 1. And different values are used for different indoor installation heights:

⚠ CAUTION

- The VRF IDU installation height cannot be less than 1.8 m. For more detailed instructions on the installation height of the IDU, please refer to the corresponding Installation Manual and Owner's Manual.
- If the installation height of the VRF IDU is less than 1.8 m, please contact your installer or dealer to receive more information and professional advice.

Operation Manual

3 Important Information for User

WARNING

- This appliance can be used by children ages 8 and above and persons with reduced physical, sensory or mental capabilities or who lack experience and knowledge only if they are supervised or have been given instruction concerning the use of the appliance in a safe way and understand the hazards involved.

Children shall not play with the appliance. Children shall not clean or maintain the appliance without supervision.

- This appliance is not intended for use by persons (including children) with reduced physical, sensory or mental capabilities, or persons who lack experience and knowledge, unless they are supervised or have been given instructions concerning the use of the appliance by a person responsible for their safety.

– Children should be supervised to ensure that they do not play with the appliance.

– The split units shall only be connected to an appliance compatible with the same refrigerant.

– The units 8-16 kW are split unit air conditioners, complying with split unit requirements of this International standard, and must only be connected to the units that have been confirmed as complying with the corresponding split unit requirements of this International standard.

- Ask your dealer to assist in the installation of the air conditioner.

Incomplete installation performed by yourself may result in a water leakage, electric shock, and fire.

- Ask your dealer for assistance with improvement, repair, and maintenance.

Incomplete improvement, repair, and maintenance may result in a water leakage, electric shock, and fire.

- To avoid electric shock, fire or injury, please turn off the power supply and call your dealer for instructions if you detect any abnormalities such as a burning smell

- Never let the indoor unit or the remote controller get wet.

This could lead to electric shock or fire.

- Never press the button of the remote controller with a hard, pointed object.

The remote controller may be damaged.

- Never replace a fuse with a fuse that has an incompatible rated current or other wires when a fuse blows out.

The use of wire or copper wire may cause the unit to break down or cause a fire.

- Exposing your body to the air flow of the air conditioner for long periods of time may be harmful to your health

- Do not insert fingers, rods or other objects into the air inlet or outlet.

When the fan is in operation, it will cause injury.

WARNING

- Never use a flammable spray, such as hair spray or lacquer paint, near the unit.

It may cause a fire.

Prior to beginning work on systems containing flammable refrigerants, safety checks are necessary to minimize the risk of ignition

- When repairing the refrigerating system, comply with the following precautions prior to conducting work on the system:

– shall be undertaken according to controlled procedures so as to minimize the risk of the presence of flammable gases or vapors while the work is being performed.

– All maintenance staff and others working in the local area shall be instructed on the nature of work being carried out. Work in confined spaces shall be avoided.

– The area shall be checked with an appropriate refrigerant detector prior to and during work, to ensure the technician is aware of potentially toxic or flammable environment. Ensure that the leak detection equipment being used is suitable for use with all applicable refrigerants, i.e., non-sparking, adequately sealed or intrinsically safe.

– If any hot work is to be conducted on the refrigerating equipment or any associated parts, appropriate fire extinguishing equipment shall be available and easily accessible. Have a dry powder or CO2 fire extinguisher adjacent to the charging area.

– When carrying out work in relation to a refrigerating system that involves exposing any pipe work, no sources of ignition shall be used in such a manner that it may lead to the risk of fire or explosion. All possible ignition sources, including cigarette smoking, should be kept sufficiently far away from the site of installation, repair, or removal and disposal of the unit, during which refrigerant can possibly be released into the surrounding space. Prior to beginning work, the area around the equipment is to be surveyed to make sure that there are no flammable hazards or ignition risks. "No Smoking" signs shall be clearly displayed.

- Ensure that the area is in the open or that it is adequately ventilated before opening the system or conducting any hot work. A degree of ventilation shall continue during the period that the work is carried out. The ventilation should safely disperse any released refrigerant and preferably expel it externally into the surroundings.

- Where electrical components are being changed, they shall be fit according to their purpose and to the correct specification. At all times the manufacturer's maintenance and service guidelines shall be followed. If in doubt, consult the manufacturer's technical department for assistance. The following checks shall be applied to installations using flammable refrigerants:

– The actual refrigerant charge is in accordance with the room size within which the refrigerant containing parts are installed;

– The ventilation machinery and outlets are operating adequately and are not obstructed;

– If an indirect refrigerating circuit is being used, the secondary circuit shall be checked for the presence of refrigerant;

- Equipment marking must remain visible and legible. Markings and signs that are illegible shall be corrected;
- Refrigerating pipe or components are installed in a position where they are unlikely to be exposed to any substances which may corrode refrigerant containing components, unless the components are constructed of materials that are inherently resistant to corrosion or are suitably protected against corrosion.
- **Repair and maintenance of electrical components shall include initial safety checks and component inspection procedures. If a fault exists that could compromise safety, then no electrical supply shall be connected to the circuit until the fault has been dealt with satisfactorily. If the fault cannot be corrected immediately but it is necessary to continue operation, an adequate temporary solution shall be used. This shall be reported to the owner of the equipment so that all parties are advised. Initial safety checks shall include:**
 - That capacitors are discharged: this shall be done in a safe manner to avoid the possibility of sparking;
 - That no live electrical components and wiring are exposed while charging, recovering or purging the system;
 - That there is continuity of grounding.
- **When repairing sealed components, all electrical supplies shall be disconnected from the equipment being worked upon prior to any removal of sealed covers, etc. If it is absolutely necessary to have an electrical supply to the equipment during servicing, then a permanently operating form of leak detection shall be installed at the most critical point to warn of a potentially hazardous situation.**
- **Particular attention shall be paid to the following to ensure that by working on electrical components, the casing is not altered in such a way that the level of protection is affected. This shall include damage to cables, an excessive amount of connections, terminals not made to their original specification, damage to seals, incorrect fitting of glands, etc.**
- **Ensure that the apparatus is mounted securely.**
- **Ensure that seals or sealing materials have not degraded to the point that they no longer prevent the ingress of flammable materials. Replacement parts shall conform with the manufacturer's specifications.**
- **Do not apply any permanent inductive or capacitance loads to the circuit without ensuring that this will not exceed the permissible voltage and current permitted for the equipment in use.**
- **Intrinsically safe components are the only types that can be worked on while live in the presence of flammable gases. The test apparatus shall be at the correct rating.**
- **Replace components only with parts specified by the manufacturer. Other parts may result in the ignition of refrigerant which has leaked into the surroundings.**

- **Check that cabling will not be subject to wear, corrosion, excessive pressure, vibration, sharp edges or any other adverse environmental effects. The check shall also take into account the effects of aging or continual vibration from sources such as compressors or fans.**
- **Under no circumstances shall potential sources of ignition be used while searching for or detection of refrigerant leaks. A halide torch (or any other detector using a naked flame) shall not be used.**
- **Electronic leak detectors may be used to detect refrigerant leaks but, in the case of flammable refrigerants, the sensitivity may not be adequate, or may need re-calibration. (Detection equipment shall be calibrated in a refrigerant-free area.) Ensure that the detector is not a potential source of ignition and is suitable for the refrigerant used. Leak detection equipment shall be set at a percentage of the LFL of the refrigerant and shall be calibrated for the refrigerant employed, and the appropriate percentage of gas (25 % maximum) is confirmed.**
- **If a leak is suspected, all naked flames shall be removed/extinguished.**
- **If a leakage of refrigerant which requires brazing is found, all of the refrigerant shall be recovered from the system, or isolated (by means of shut off valves) in a part of the system remote from the leak.**
- **When opening the refrigerant circuit to make repairs – or for any other purpose – conventional procedures shall be used. However, for flammable refrigerants it is important that best practice is followed since flammability is a consideration. The following procedure shall be followed:**
 - Remove refrigerant;
 - Purge the circuit with inert gas;
 - Evacuate;
 - Purge with inert gas;
 - Open the circuit by cutting or brazing.
- **The refrigerant charge shall be recovered into the correct recovery cylinders. The system shall be "flushed" with OFN to render the unit safe. This process may need to be repeated several times. Do not use compressed air or oxygen for this task.**
- **Flushing shall be achieved by breaking the vacuum in the system with OFN and continuing to fill until a working pressure is achieved, then venting to the surroundings, and finally pulling down to a vacuum. This process shall be repeated until no refrigerant is within the system. When the final OFN charge is used, the system shall be vented down to atmospheric pressure to enable work to take place. This operation is absolutely vital if brazing operations on the pipework are to take place.**
- **Ensure that the outlet for the vacuum pump is not close to any ignition sources and there is ventilation available.**
- **Ensure that contamination of different refrigerants does not occur when using charging equipment. Hoses or lines shall be as short as possible to minimise the amount of refrigerant they contain.**

- Cylinders shall be kept upright.
- Ensure that the refrigeration system is grounded prior to charging the system with refrigerant.
- Label the system when charging is complete (if it is not already labeled).
- Take extreme care not to overfill the refrigeration system.
- Prior to recharging the system it shall be pressure tested with OFN. The system shall be leak tested on completion of charging but prior to commissioning. A follow up leak test shall be carried out prior to leaving the site.
- Before carrying out this procedure, it is essential that the technician is completely familiar with the equipment and all its detail. It is recommended that all refrigerants are recovered safely. Prior to the task being carried out, an oil and refrigerant sample shall be taken in case analysis is required prior to re-use of reclaimed refrigerant. It is essential that electrical power is available before the task is commenced.
 - a) Become familiar with the equipment and its operation.
 - b) Isolate system electrically.
 - c) Before attempting the procedure ensure that:
 - mechanical handling equipment is available, if required, for handling refrigerant cylinders;
 - all personal protective equipment is available and being used correctly;
 - the recovery process is supervised at all times by a competent person;
 - recovery equipment and cylinders conform to the appropriate standards.
 - d) Pump down refrigerant system, if possible.
 - e) If a vacuum is not possible, make a manifold so that refrigerant can be removed from various parts of the system.
 - f) Make sure that the cylinder is situated on the scales before recovery takes place.
 - g) Start the recovery machine and operate it in accordance with the manufacturer's instructions.
 - h) Do not overfill cylinders. (No more than 80 % volume liquid charge).
 - i) Do not exceed the maximum working pressure of the cylinder, even temporarily.
 - j) When the cylinders have been filled correctly and the process has been completed, make sure that the cylinders and the equipment are removed from site promptly and all isolation valves on the equipment are closed off.
 - k) Recovered refrigerant shall not be charged into another refrigeration system unless it has been cleaned and checked.
- Equipment shall be labeled stating that it has been de-commissioned and emptied of refrigerant. The label shall be dated and signed. Ensure that there are labels on the equipment stating the equipment contains flammable refrigerant.
- When removing refrigerant from a system, either for servicing or decommissioning, it is recommended that all refrigerants are removed safely.

- When transferring refrigerant into cylinders, ensure that only appropriate refrigerant recovery cylinders are used. Ensure that the correct number of cylinders for holding the total system charge is available. All cylinders to be used are designated for the recovered refrigerant and labeled for that refrigerant (i.e., special cylinders for the recovery of refrigerant). Cylinders shall be complete, with pressure-relief valves and associated shut-off valves in good working order. Empty recovery cylinders are evacuated and, if possible, cooled before recovery occurs.
- Recovery equipment shall be in good working order and have an easily accessible set of instructions concerning the equipment. and the equipment shall be suitable for the recovery of all appropriate refrigerants including, when applicable, flammable refrigerants. In addition, a set of calibrated weighing scales shall be available and in good working order. Hoses shall be complete with leak-free disconnect couplings and in good condition. Before using the recovery machine, check that it is in satisfactory working order, has been properly maintained and that any associated electrical components are sealed to prevent ignition in the event of a refrigerant release. Consult the manufacturer if assistance is required.
- The recovered refrigerant shall be returned to the refrigerant supplier in the correct recovery cylinder, and the relevant waste transfer note arranged. Do not mix refrigerants in recovery units and especially not in cylinders.
- If compressors or compressor oils will be removed, ensure that they have been evacuated to an acceptable level to make certain that flammable refrigerant does not remain within the lubricant. The evacuation process shall be carried out prior to returning the compressor to the suppliers. Electric heating will only be employed on the compressor body to accelerate this process. When oil is drained from a system, it shall be carried out safely.

WARNING

- **Never touch the air outlet or the horizontal blades while the swing flap is in operation.**
Your fingers may become caught or the unit may break down.
- **Never put any objects into the air inlet or outlet.**
Objects touching the fan at high speed can be dangerous.
- **Do not dispose of this product as unsorted municipal waste. This waste should be collected separately for special treatment.**
Do not dispose of electrical appliances as unsorted municipal waste. Use separate collection facilities. Contact your local government for information regarding the connection systems available 
- **If electrical appliances are disposed of in landfills or dumps, hazardous substances can leak into the groundwater and get into the food chain, harming your health and well-being.**
- **To prevent refrigerant leak, contact your dealer.**
When the system is installed and operates in a small room, it is required to maintain the concentration of the refrigerant below the limit, in case a leak occurs. Otherwise, oxygen in the room may be affected, resulting in a serious accident.
- **Keep ventilation openings clear of obstruction.**

NOTE

- **Do not use the air conditioner for other purposes.**
In order to avoid any quality deterioration, do not use the unit for the cooling of precision instruments, food, plants, animals or works of art.
- **Arrange the drain hose to ensure smooth drainage.**
Incomplete drainage may cause wetting of the building, furniture, etc.

CAUTION

- **Before cleaning, be sure to stop the operation, turn the breaker off or unplug the supply cord.**
Otherwise, electric shock and injury may occur.
- **In order to avoid electric shock or fire, make sure that an earth leak detector is installed.**
- **Be sure the air conditioner is grounded.**
In order to avoid electric shock, make sure that the unit is grounded and that the earth wire is not connected to a gas or water pipe, lightning conductor or telephone earth wire.

- **In order to avoid injury, do not remove the fan guard of the outdoor unit.**
- **Do not operate the air conditioner with wet hands.**
An electric shock may happen.
- **Do not touch the heat exchanger fins. These fins are sharp and could cut you.**
- **Do not place items which might be damaged by moisture under the indoor unit.**
Condensation may form if the humidity is above 80%, the drain outlet is blocked or the filter is polluted.
- **After extended use, inspect the unit stand and fitting for damage.**
If damaged, the unit may fall and cause injury.
- **Never touch the internal parts of the unit.**
Do not remove the front panel. Some parts inside are dangerous to touch, and machine troubles may occur.
- **Never expose little children, plants or animals directly to the air flow.**
Adverse influence to little children, animals and plants may occur.
- **Do not allow a child to climb on the outdoor unit and avoid placing any objects on it.**
Injury may occur due to falling or tumbling.
- **Do not operate the air conditioner when using a room fumigation - type insecticide.**
Failure to observe this precaution could cause the chemicals to become deposited in the unit, which could endanger the health of those who are hypersensitive to chemicals.
- **Do not place appliances which produce open flame in places exposed to the air flow from the unit or under the indoor unit.**
It may cause incomplete combustion or deformation of the unit due to the heat.
- **Do not install the air conditioner in a location where flammable gas may leak out.**
If the gas leaks out and stays around the air conditioner, a fire may break out.
- **When the combination ratio of IDUs is greater than or equal to 110%, in order to ensure the capacity of the machine, try to turn on the indoor units at different time.**
- **The outdoor unit window-shades should be cleaned periodically to prevent jamming.**
This window-shades are the heat dissipation outlets of components, if it is jammed, it will cause the components shorten their service life spans because of being overheated for an extended period.

- The temperature of refrigerant circuit will be high. Please keep the interconnection cable away from the copper tube.
- The sound pressure level is below 70 dB(A).
- This appliance is intended to be used by expert or trained users in shops, in light industry and on farms, or for commercial use by lay persons.

4 System Information

4.1 System Layout

Case 1: ODU is connected with VRF IDU only

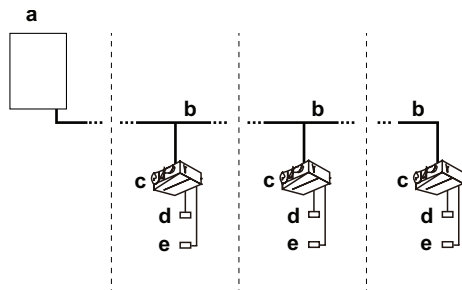

- a Heat pump outdoor unit
- b Refrigerant piping
- c VRF indoor unit
- d Wired controller (optional)
- e Display box (optional)

Figure 4-1

Case 2: ODU is connected with VRF IDU and DHW kit (DHW kit cannot be independently connected with the ODU)

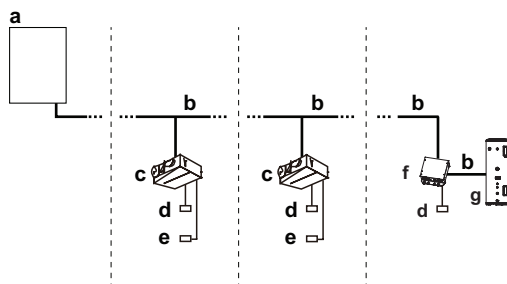

- a Heat pump outdoor unit
- b Refrigerant piping
- c VRF indoor unit
- d Wired controller (optional)
- e Display box (optional)
- f DHW kit
- g Water tank

Figure 4-2

Case 3: ODU is connected with VRF IDU and hydraulic module

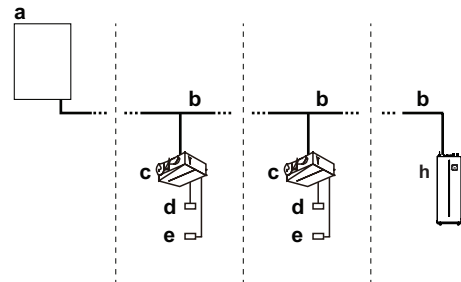

- a Heat pump outdoor unit
- b Refrigerant piping
- c VRF indoor unit
- d Wired controller (optional)
- e Display box (optional)
- h Hydraulic module

Figure 4-3

Case 4: ODU is individually connected with hydraulic module

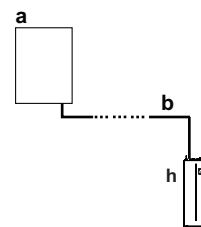

- a Heat pump outdoor unit
- b Refrigerant piping
- h Hydraulic module

Figure 4-4

5 Operating Instructions

5.1 Operating Range

Use the system at the following temperatures to ensure safe and effective operation. The operating range for the air conditioner is shown in Table 5-1.

Table 5-1

Model		8/10/12/14/16kW	
Air conditioner	Cooling	Indoor temperature/dry bulb	17°C to 32°C
		Indoor temperature/wet bulb	13°C to 23°C
		Outdoor temperature/dry bulb	-15°C to 46°C (8kW) -15°C to 55°C (10/12/14/16kW)
	Heating	Indoor temperature/dry bulb	17 °C to 30 °C
		Outdoor temperature/dry bulb	-20 °C to 27 °C
		Outdoor temperature/wet bulb	-20 °C to 16.5 °C
Dry	Indoor temperature/dry bulb	12 °C to 32 °C	
	Indoor temperature/wet bulb	9 °C to 23 °C	
	Outdoor temperature/dry bulb	-15°C to 46°C (8kW) -15°C to 55°C (10/12/14/16kW)	
DHW kit/ hydraulic module	Heating	Outdoor temperature/dry bulb	-20 °C to 35 °C
		Outdoor temperature/wet bulb	-20 °C to 28 °C
		Outlet water	25 °C to 60 °C
	DHW	Outdoor temperature/dry bulb	-20 °C to 43 °C
		Outdoor temperature/wet bulb	-20 °C to 30 °C
		Outlet water	25 °C to 60 °C

Caution

- If the above operating conditions cannot be met, the safety protection function may be triggered and the air conditioner may malfunction.
- When the unit operates in "Cool" mode in a relatively humid environment (relative humidity higher than 80%), condensation may occur on the surface of the IDU, causing water to drip. In this case, turn the air baffle to the maximum air outlet position and set the fan speed to "High".
- Outdoor operating temperature under -5 °C in "Cool" mode, the startup capacity of IDU must meet at least 30% of ODU capacity.

5.2 Operating System

5.2.1 System operation

The operating program varies with different combinations of outdoor unit and controller.

To protect this unit, turn on the main power supply 12 hours before operation.

If there is a power outage while the unit is running, the unit will automatically restart its operation when the power supply resumes.

5.2.2 Cooling, Heating, DHW, Fan Only and Auto

The IDU of the air conditioning system can be controlled separately, but the ODU cannot operate in both heating and cooling modes or DHW and cooling modes simultaneously.

When the cooling mode conflicts with the heating mode, the operating mode of the system is determined by the DIP switch on the ODU inspection board, or set by the wired controller of the DHW kit, and by the wired controller of the hydraulic module.

Table 5-2

	First enabled priority (default)	The operating mode of the IDU that is first activated determines the system operating mode.
ODU	Cooling mode priority	When the cooling mode priority is selected, the heating mode of the IDU stops running, and the cooling and fan only modes operate normally. However, the DHW kit or hydraulic module can manually turn on electric heating for heating or DHW operation.
	Auto mode priority	The IDUs automatically select cooling or heating priority based on ambient temperature
	In response to cooling mode only	The IDUs in cooling and fan only modes operate normally, while the IDUs in heating and DHW modes stop operating. However, the DHW kit or hydraulic module can manually turn on electric heating for heating or DHW operation.
	In response to Heating mode only	The IDUs in heating mode and DHW mode operate normally, while the IDUs in cooling and fan only modes stop operating.
	VIP mode priority	If the VIP IDU has been set and turned on, the operating mode of the VIP IDU is the priority mode of the system.
	Heating mode priority	When heating mode priority is selected, the cooling and fan only modes of the IDU stop running, while the heating and DHW modes operate normally.
DHW kit or hydraulic module	DHW priority	When DHW priority is selected on the wired controller of the DHW kit or hydraulic module, the DHW mode of the IDU operates normally, and the heating, cooling, and fan only modes all stop running.

5.2.3 Heating operation

It may take longer to reach the set temperature for general heating operation than for cooling operation.

The following operation is performed in order to prevent the heating capacity from dropping or cold air from blowing

Defrost Operation

In the heating operation, as the outdoor temperature decreases, frost may be formed on the heat exchanger in the outdoor unit, making it more difficult for the heat exchanger to heat up the air. The heating capacity decreases, and a defrosting operation needs to be performed on the system in order for the system to provide sufficient heat to the indoor unit. At this point, the indoor unit will show "dF" on the display screen.

The indoor fan motor will automatically stop running so as to prevent cold air from coming out of the indoor unit when the heating operation starts. This process will take some time. This is not a malfunction.

INFORMATION

- In heating mode, the air-conditioning system absorbs heat from the outdoor air and releases heat to the indoor side. When the outdoor temperature is low, less heat is released. This is the principle of heat pump.
- When the outdoor temperature is extremely low, the heating capacity of the air conditioner decreases, and other heating equipment may need to be added
- The motor in the IDU will continue running for about 40 seconds to remove residual heat when the IDU receives a shutdown command while heating.

5.2.4 DHW Mode

The general DHW mode may take longer to reach the set temperature than the cooling and heating modes.

The following operations are carried out to prevent a decrease in DHW capacity or water temperature from falling lower than the set temperature

Defrosting

During operation in DHW mode, as the outdoor temperature decreases, frost may form on the heat exchanger in the ODU, making it more difficult for the heat exchanger to heat up the air. The DHW capacity decreases, and a defrosting operation needs to be performed on the system so that the system can provide sufficient heat to the IDU. At this point, the IDU will show "dF" (the defrost operation) on the display screen.

The operating status of the water pump in the hydraulic module will change, and the electric heating of the DHW kit and the hydraulic module will also automatically start. These measures are all aimed at preventing the outlet water temperature from falling too low. This process takes some time. This is not a malfunction.

INFORMATION

- In DHW mode, the air conditioning system absorbs heat from the outdoor air and releases it into the water system. When the outdoor temperature is low, less heat is released. This is the principle of how a heat pump works.
- When the outdoor temperature is extremely low, the heating capacity of the air conditioner decreases, and it may be necessary to turn on the electric heating of the DHW kit or hydraulic modules.

5.2.5 To operate the system

Press the operation mode selector button on the user interface and select the operation mode.

- Ⓐ Auto mode
- ❄ Cooling mode
- ☁ Dry mode
- 🌀 Fan mode
- ☀ Heating mode
- 🚿 DHW mode

Operation

Press the ON/OFF button on the user interface.

Result: The running light turns on and the system starts to run.

Stop

Press the ON/OFF button on the user interface.

Result: The running light is off, and the system stops running.

NOTE

Once the unit has stopped running, do not disconnect the power immediately. Wait for at least 10 minutes.

Adjust

Refer to the user manual for the controller on how to set the required temperature, fan speed and air flow direction.

5.3 Dry Program

5.3.1 System operations

The function in this program uses the minimum temperature drop (minimum indoor cooling) to bring about a drop in humidity in the room.

The temperature and fan speed cannot be set.

5.4 Cutting off Power Supply

If there is a power outage while the unit is running, the unit will automatically restart when the power supply resumes.

Misoperation

If misoperation happens, please disconnect the power from the system and then reconnect it after a few minutes.

5.5 Protection Procedure

5.5.1 Protection Functions

A protection feature prevents the air conditioner from being activated within 4 minutes when it restarts immediately after operation.

5.5.2 Protective Equipment

This protective equipment will enable the air conditioner to stop when the air conditioner is forced to run.

The protective equipment may be activated in the following circumstances:

Cooling

- The air inlet or air outlet of the ODU is blocked.
- Strong wind is continuously blowing into the air outlet of the ODU.

Heating

- Too much dust and rubbish are stuck to the dust filter of the IDU.
- The air outlet of IDU is blocked.

Caution

- When the protective equipment activates, please turn off the power, and restart operations after the problem is solved.

6 Maintenance and Repair

6.1 About Refrigerant

This product contains fluorinated greenhouse gases as stipulated in the Kyoto Protocol. Do not discharge the gas into the atmosphere.

Refrigerant Type: R32

GWP Value: 675

Law requires that refrigerant must be checked regularly for leakages. Please contact the installation personnel for more information.

WARNING

- The refrigerant in the air conditioner is safe, and usually does not leak.
- Do not use the air conditioner again until the maintenance personnel has confirmed that the refrigerant leakage has been sufficiently resolved.

6.2 After-sales Service and Warranty

6.2.1 Warranty Period

This product comes with a warranty card that was completed by the dealer during installation. The customer must check the completed warranty card and keep it properly.

If you need to repair the air conditioner during the warranty period, please contact the dealer and provide the warranty card.

When you request assistance from the dealer, please remember to state:
Complete model name of the air conditioner

Date of installation

Details on the fault symptoms or errors

Warning

Do not attempt to modify, dismantle, remove, reinstall or repair this unit, as the improper dismantling or installation may result in electric shock or fire. Please contact the agent.

If the refrigerant accidentally leaks, make sure that there are no open flames around the unit. Refrigerant itself is completely safe, non-toxic and non-flammable, but it will produce toxic gases when it accidentally leaks and comes in contact with flammable substances generated by heaters and burning devices in the room. Qualified maintenance personnel must verify that the point of leakage has been repaired or rectified before you resume operations of the unit.

6.2.2 Shorter Maintenance and Replacement Cycle

In the following situations, the "maintenance cycle" and "replacement cycle" may be shortened.

The unit is used in the following situations:

- Temperature and humidity fluctuations are outside the normal range.
- Large power fluctuations (voltage, frequency, waveform distortion etc.) (must not use the unit if the power fluctuations exceed the allowed range).
- Frequent collisions and vibrations.
- The air may contain dust, salt, harmful gases or oils such as sulphite and hydrogen sulphide.
- Frequently turning the unit on and off or operating the unit for too long (in places where the air conditioning is on for 24 hours a day).

6.2.3 Maintenance and Repair

Each refrigerating system shall be subjected to preventative maintenance in accordance with legal requirements. The frequency of maintenance depends on the type, size, age, use, etc. of the system. In many cases, more than one maintenance service is required per year.

The operator of the refrigerating system shall ensure that the system is inspected, regularly supervised and maintained.

Systems shall be inspected for tightness by a qualified person. If, during the inspection, a leak is suspected, e.g., through refrigerant temperature checks or capacity reduction, then the location of the leak shall be identified with suitable detection equipment and shall be repaired and checked again after the repair in accordance with national regulations. The results of the inspection and measures taken afterwards shall be included in the logbook.

Regular leak tests and inspections shall be carried out, including tests and inspections of the safety equipment.

WARNING

- When the breaker was broken, do not use any unspecified breaker or other wire to replace the original breaker. The use of electrical wires or copper wires may cause the unit to malfunction or cause a fire.
- Do not insert your fingers, sticks, or other items into the air inlet or outlet. Do not remove the fan mesh cover. When the fan rotates at a high speed, it could cause bodily injury.
- It is very dangerous to check the unit when the fan is rotating.
- Make sure you turn off the main breaker before any maintenance work begins.
- Check the supporting and base structure of the unit for any damages after a long period of use. The unit could fall and cause personal injury if there is any damage.
- Do not check or repair the unit on your own. Please get qualified professionals to conduct any checks or repairs.

NOTE

- Do not use substances like gasoline, diluent, or chemical dust cloths to wipe the operations panel of the controller. Doing so could remove the surface layer of the controller. If the unit is dirty, immerse a cloth in diluted and neutral detergent, wring it out, and then use it to clean the panel. Lastly, wipe it with a dry cloth.
- Ensure that the area is in the open or that it is adequately ventilated before opening the system or conducting any hot work. A degree of ventilation shall continue during the period that the work is carried out. The ventilation should safely disperse any released refrigerant and preferably expel it externally into the surroundings.

6.2.3.1 Maintenance Before Long Shutdown

For example, at the end of winter and summer.

- Run the indoor unit in the fan mode for about half a day to dry the internal parts of the unit.
- Turn off the power supply.
- Clean the air filter and external shell of the unit. Please contact the installation or maintenance personnel to clean the air filter and external shell of the indoor unit. The installation/operation manual of the specialized indoor unit includes maintenance tips and cleaning procedures. Make sure that the clean air filter is installed in its original position.

6.2.3.2 Maintenance After Long Shutdown

For example, in early summer or winter.

- Check and remove all objects that may clog the air inlets and outlets of the indoor and outdoor units.
- Clean the air filter and external shell of the unit. Please contact the installation or maintenance personnel. The installation/operation manual of the indoor unit includes maintenance tips and cleaning procedures. Make sure that the clean air filter is installed in its original position.
- Turn on the main power supply 12 hours before this unit is operated in order to ensure that the unit runs smoothly. The user interface is displayed once the power is turned on.

7. Troubleshooting

7.1 Air Conditioner Problems and Causes

If one of the following malfunctions occurs, stop the air conditioner from operating, shut off the power, and contact your dealer.

- The remote controller malfunctions or the buttons do not work well.
- A safety device such as a leakage breaker or a circuit breaker is frequently tripped.
- Dust, moisture and other particles have entered the unit.
- Water leaks from the IDU.
- Other malfunctions.
- The operation lamp flashes rapidly (twice every second).
- This lamp is still flashing rapidly after the power is restarted.

If the system does not properly operate other than the above mentioned cases or if the above mentioned malfunctions are evident, use the following procedures to check the system. (See Table 7-1)

7.2 Remote Controller Problems and Causes

Before requesting service or repair, check the following points.

(See Table 7-2)

Table 7-1

Symptom	Possible Cause	Solution
The unit does not start.	<ul style="list-style-type: none"> Power failure. Power breaker is off. Batteries of the remote controller are depleted or there is another problem with the controller. 	<ul style="list-style-type: none"> Wait for the power supply to be restored. Turn on the power. Replace the batteries or check the controller.
Air is flowing normally but offers zero cooling effect.	<ul style="list-style-type: none"> Temperature is not set correctly. The unit's compressor is in the 3-7 minutes protection period. 	<ul style="list-style-type: none"> Set the temperature properly. Wait.
Units start or stop frequently.	<ul style="list-style-type: none"> Refrigerant is too little or too much. There is air or no condensing gas in the refrigerating circuit. The compressor is malfunctioning. Voltage is too high or too low. The system circuit is blocked. 	<ul style="list-style-type: none"> Check for leakage and correctly recharge refrigerant. Vacuum and recharge refrigerant. Maintain or change compressor. Install a manostat. Find reasons and solutions.
Poor cooling effect.	<ul style="list-style-type: none"> The heat exchangers of the ODU and IDU are dirty. The air filter is dirty. Inlet/outlet of IDU/ODU is blocked. Doors and windows are open. The unit is directly exposed to sunlight. There are too many heat sources. Outdoor temp. is too high. Leakage of refrigerant or lack of refrigerant. 	<ul style="list-style-type: none"> Clean the heat exchanger. Clean the air filter. Eliminate all dirt and allow air to flow smoothly. Close doors and windows. Install or close curtains in order to shade the unit from sunshine. Reduce heat source. Unit cooling capacity is reduced (normal) Check for leakage and correctly recharge refrigerant.
Poor heating effect.	<ul style="list-style-type: none"> Outdoor temperature is lower than 7°C. Doors and windows are not completely closed. Leakage of refrigerant or lack of refrigerant. 	<ul style="list-style-type: none"> Use heating devices. Close doors and windows. Check for leakage and correctly recharge refrigerant.

Table 7-2

Symptom	Troubleshooting	Solution
The fan speed cannot be changed.	Check whether the MODE indicated on the display is "AUTO".	When the automatic mode is selected, the air conditioner will automatically change its fan speed.
	Check whether the MODE indicated on the display is "DRY".	When Dry mode is selected, the air conditioner will automatically change its fan speed. When dry operation is selected, the air conditioner automatically changes the fan speed. Fan speed can be selected in "COOL", "FAN ONLY", and "HEAT" modes
The remote controller signal is not transmitted even when the ON/OFF button is pushed.	Check whether the batteries in the remote controller are exhausted.	The power supply is off.
The TEMP. indicator does not come on.	Check whether the MODE indicated on the display is FAN ONLY.	The temperature cannot be set when the unit is working in FAN mode.
The indication on the display disappears after a lapse of time.	Check whether the timer has ended when TIMER OFF is indicated on the display.	Air conditioner operation will stop when the set time is reached.
The TIMER ON indicator goes off after a lapse of time.	Check whether the timer starts when TIMER ON is indicated on the display	When the set time is reached, the air conditioner will automatically start and the corresponding indicator will turn off.
The IDU does not produce a sound when the ON/OFF button is pressed.	Check whether the signal transmitter of the remote controller is properly pointing towards the infrared signal receiver of the IDU when the ON/OFF button is pressed.	Air conditioner operation will stop when the set time is reached.

7.3 Fault Symptom: Non Air Conditioning Issues

Symptom 1: The system does not operate

- The air conditioner does not start immediately after the ON/OFF button on the remote controller is pressed.

If the operating indicator lights up, the system is working normally. To prevent overloading of the compressor motor, the air conditioner starts 3 minutes after it is turned on.

- If the operation lamp and the "PRE-DEF indicator (cooling and heating type) or fan only indicator (cooling only type)" light up, it means you must choose heating mode. When the unit has just started up, if the compressor has not started, the IDU displays "anti cold wind" protection because the air outlet temperature is too low.

Symptom 2: The system switches into the fan mode during cooling

- In order to prevent the indoor evaporator from frosting, the system will switch into fan mode automatically, and promptly return to cooling mode.

- When the room temperature drops to the set temperature, the compressor goes off and the IDU switches to fan mode; when the temperature increases, the compressor starts again. It is same in heating mode.

Symptom 3: White mist comes out of unit

Symptom 3.1: IDU

- When humidity is high during cooling operation, if the interior of the IDU is dirty, the indoor temperature distribution will be uneven. The interior of the IDU needs to be cleaned. Ask the dealer for detailed information on how to clean the unit. This operation requires a qualified service person

Symptom 3.2: IDU, ODU

- When the system switches over to heating operation after defrost operation, moisture generated by defrosting becomes steam and is discharged.

Symptom 4: Air conditioner generates noise during cooling

Symptom 4.1: IDU

- A "zeen" sound is heard immediately after the power supply is turned on. The electronic expansion valve inside an indoor unit starts working and makes the noise. it will reduce in about one minute.

A continuous low "shah" sound is heard when the system is in COOL mode or stops. This noise can be heard when the drainage pump is running (optional accessory).

A "pishi-pishi" squeaking sound is heard when the system stops after heating operation. Expansion and contraction of plastic parts caused by temperature changes can make this noise.

Symptom 4.2: IDU, ODU

- A continuous low hissing sound is heard when the system is in operation. This is the sound of refrigerant gas flowing through both the IDU and ODU.
- A hissing sound is heard when the system starts or stops operation or after the defrosting operation has been completed. This is the noise of refrigerant that occurs when it stops flowing or its flow changes.

Symptom 4.3: ODU

- When the tone of operating noise changes, the noise is caused by the change of frequency.

Symptom 5: Dust comes out of the unit

- When the unit is being used for the first time after a long period of disuse, dust has got into the unit, which leads to this symptom.

Symptom 6: The units give off odours

- This unit will absorb the odours of rooms, furniture, cigarettes and others, and then disperse the odours again.
- During operation, the speed of the fan is controlled to optimize product performance.

Symptom 7: The ODU fan does not spin.

8 Relocation

Please contact the dealer to dismantle and reinstall all the units. You need specialized skills and technology to move the units.

9 Disposal

This unit uses hydrogen fluorocarbons. Please contact the dealer when you want to dispose of this unit. Law requires that the collection, transportation and disposal of refrigerants must conform with the regulations governing the collection and destruction of hydrofluorocarbons.

Installation Manual

10 Precautions

- Before installing the unit, ensure that all Local, National and International regulations are satisfied, and read these "PRECAUTIONS" carefully.
- The precautions described below include important items regarding safety. They must be strictly observed.
- After the installation work, perform a test run to check for any problems.
- Explain how to use and maintain the unit to the customer following the Owner's Manual.
- Turn off the main power supply breaker before maintaining the unit.
- Retain the Installation Manual and the Owner's Manual.

Caution

- Specialized tools are required for the installation of air conditioner with new refrigerant (R32).

THIS AIR CONDITIONER ADOPTS THE NEW HFC REFRIGERANT(R32) WHICH DOES NOT DESTROY THE OZONE LAYER.

The characteristics of R32 refrigerant are: it is a hydrophilic, oxidizing membrane or oil, and its pressure is approx. 1.6 times higher than that of refrigerant R22. Accompanied with the new refrigerant, refrigerating oil has also been changed. Therefore, during installation work, be sure that water, dust, former refrigerant, or refrigerating oil does not enter the refrigerating cycle.

To prevent charging an incorrect refrigerant and refrigerating oil, the sizes of connecting sections of charging port of the main unit and installation tools are different from those for the conventional refrigerant.

This means that exclusive tools are required for the new refrigerant (R32):
For connecting pipes, use new and clean piping designed for R32, and please take care so that water or dust does not enter. In addition, do not use the existing piping because there are problems with pressure-resistance force and impurities in it.

⚠ Warning

- Do not directly connect the appliance to the main power supply. Install the main power supply breaker.
- If the supply cord is damaged, it must be replaced by the manufacturer or its service agent or a similarly qualified person in order to avoid creating a hazard.
- An all-pole disconnection switch which has a contact separation of at least 3 mm in all poles shall be connected using fixed wiring.
- The appliance shall be installed in accordance with national wiring regulations.
- The temperature of the refrigerant circuit will be high. Please keep the interconnection cable away from the copper tube.
- An all-pole disconnection device which has at least 3 mm of separation distance in all poles and a residual current device (RCD) with a rating of above 10 mA shall be incorporated in the fixed wiring in accordance with national requirements.
- The power cable model is H05RN-R/H07RN-F or above.
- Ask an authorized dealer or qualified installation professional to install or maintain the air conditioner.
- Incorrect installation may result in water leakage, electric shock or fire.
- Turn off the main power supply breaker before attempting any electrical work.
- Make sure all power breakers are off. Failure to do so may cause electric shock.
- Connect the connecting cable correctly.
- If the connecting cable is connected incorrectly, electric parts may become damaged.
- When relocating the air conditioner that is to be installed, be very careful to prevent the entry of any gaseous matter other than the specified refrigerant into the refrigeration cycle.
- If air or any other gas is mixed into the refrigerant, the gas pressure in the refrigeration cycle can become abnormally high and it may cause pipes to burst, leading to injury.
- Do not modify this unit by removing any of the safety guards or by by-passing any of the safety interlock switches.
- Exposure of the unit to water or other moisture before installation may cause a short-circuiting of electrical parts.
- Do not store the unit in a wet basement or expose it to rain or water.
- After unpacking the unit, examine it carefully to see if there is possible damage.
- Do not install the unit in a place that might increase the vibration of the unit.
- To avoid personal injury (with sharp edges), be careful when handling parts.
- Perform installation work properly according to the Installation Manual.
- Incorrect installation may result in water leakage, electric shock or fire.
- When the air conditioner is installed in a small room, take appropriate measures to ensure that the concentration of refrigerant leakage occurring in the room does not exceed the critical level.
- Install the air conditioner securely in a location where the base can adequately sustain the weight.
- Perform the specified installation work to guard against earthquakes.
- If the air conditioner is not installed properly, the unit could fall and cause an accident.

- If refrigerant gas has leaked during installation, ventilate the room immediately.
- If the leaked refrigerant gas comes into contact with fire, noxious gas may be generated.
- After the installation, confirm that refrigerant gas does not leak.
- If refrigerant gas leaks into the room and flows near a source of flame, such as a cooking range, noxious gas might be generated.
- Electrical work must be performed by a qualified electrician in accordance with the Installation Manual. Make sure the air conditioner uses a dedicated power supply.
- An insufficient power supply capacity or inappropriate installation may cause fire.
- Use the specified cables for wiring to connect the terminals securely, and to prevent external forces applied to the terminals from affecting the terminals.
- Be sure to provide grounding.
- Do not connect ground wires to gas pipes, water pipes, lightning rods or ground wires for telephone cables.
- Conform to the regulations of the local electric company when wiring the power supply.
- Improper grounding may cause electric shock.
- Do not install the air conditioner in a location subject to a risk of exposure to combustible gas.
- If combustible gas leaks and stays around the unit, a fire may occur.

Required tools for installation work

- 1) Phillips screw driver
- 2) Hole core drill (65 mm)
- 3) Spanner
- 4) Pipe cutter
- 5) Knife
- 6) Reamer
- 7) Gas leak detector
- 8) Tape measure
- 9) Thermometer
- 10) Mega-tester
- 11) Electro circuit tester
- 12) Hexagonal wrench
- 13) Flaring tool
- 14) Pipe bender
- 15) Level vial
- 16) Metal saw
- 17) Gauge manifold (Charge hose: R32 special requirement)
- 18) Vacuum pump (Charge hose: R32 special requirement)
- 19) Torque wrench

Outer diam	Torque wrench[N.m(kgf.cm)]
Φ6.35(1/4)	14.2~17.2(144~176)
Φ9.52(3/8)	32.7~39.9(333~407)
Φ12.7(1/2)	49.5~60.3(504~616)
Φ15.9(5/8)	61.8~75.4(630~770)
Φ19.1(3/4)	97.2~118.6(990~1210)

- 20) Copper pipe gauge adjusting projection margin
- 21) Vacuum pump adapter

The equipment complies with IEC 61000-3-12.

11. Packing Box

11.1 Overview

This chapter mainly introduces the subsequent operations after the ODU has been delivered to site and unpacked.

This specifically including the following information:

Please remember the following:

- Dismantle and dispose of the ODU.
- Remove the accessories of the ODU.
- Dismantle the transport rack.

Please remember the following:

- At the time of delivery, check the unit for any damage. Report any damage immediately to the carrier's claim agent.
- As much as possible, transport the packaged unit to its final installation site to prevent damage during the handling process.
- Take note of the following items when transporting the unit:



Fragile. Handle with care.



Keep the front of the unit facing upwards so as not to damage the compressor.

- Select the unit transportation path in advance.

11.2 Transportation

Lifting method

Caution

- Do not remove any packaging during lifting. If the unit is not packaged or the packaging is damaged, please use gaskets or packaging materials to protect the unit.
- Use a belt that is sufficient to support the weight of the unit, and with a width of at least 20 mm.
- Images are for reference purpose only. Please refer to the actual product.
- The belt must have enough strength to bear the weight of the unit; Maintain balance of the unit and ensure safe and stable lifting of the unit.

- Well-packaged

Please lift the unit while it is still packaged or protected and do not remove any packaging before lifting.

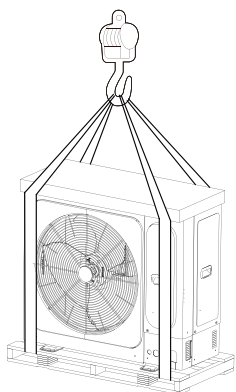

Figure 11-1

- Unpackaged

If the packaging is damaged, the under plate shown in the following figure shall be used for protection.

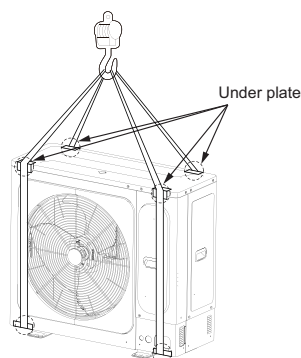

Figure 11-2

The center of gravity is shown in the following figure:

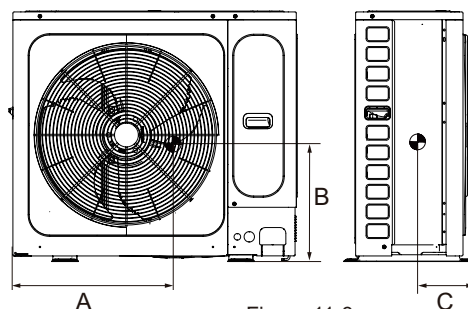

Figure 11-3

Table 11-1

Unit: mm

Model	A	B	C
8-10kW	506	413	110
12kW	551	420	63.5
14-16kW	580	410	99.2

- Forklift lifting method

When using a forklift to move the unit, insert the fork into the opening at the bottom of the unit, as shown in the following figure.

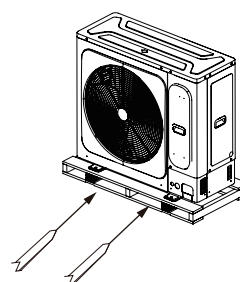

Figure 11-4

11.3 Unpacking the ODU

Remove the unit from the packing materials:







- Be careful not to damage the unit when you use a cutting tool to cut the packaging film.
- Remove the six nuts on the back of the wooden bracket.

Caution

- Handle plastic film correctly. Keep away from children.
- Potential risk: Asphyxia.

11.4 Attached Fittings

Table 11-2 Installation fittings

Name	Shape	Quantity
1. ODU Owner's and Installation Manuals		1
2. Water outlet pipe connector		1
3. Cable grommet (10/12/14/16 kW)		2
4. Network matching		1
5. Connecting pipe (14/16 kW)		1
6. Magnetic Ring		1

⚠ Caution

- Check if any accessory in the above figure is missing. All the accessories must be properly maintained.
- All the fittings shall be factory fittings.
- Wired/Remote controller - purchase separately.
- Outlet sealant - purchase separately.

12 ODU Combination Ratio

- Case 1: ODU is connected with VRF IDU only

Table 12-1

ODU model (kW)	Capacity of ODU (HP)	Number of IDUs	Combination ratio
8	3.0	1~4	50%~130%
10	3.6	1~6	50%~130%
12	4.5	1~7	50%~130%
14	5.0	1~8	50%~130%
16	6.0	1~9	50%~130%

- Case 2: ODU is connected with VRF IDU and DHW KIT (DHW kit cannot be independently connected with the ODU)

Table 12-2

ODU model (kW)	Capacity of ODU (HP)	Number of IDUs	Combination ratio of VRF IDU	Number of DHW kit(s)
12	4.5	2~7	50%~130%	1

- Case 3: ODU is connected with VRF IDU and hydraulic module

Table 12-3

ODU model (kW)	Capacity of ODU (HP)	Number of IDUs	Combination ratio of VRF IDU	Number of hydraulic modules
8	3.0	2~4	50%~100%	1
10	3.6	2~6	50%~100%	1
12	4.5	2~7	50%~100%	1
14	5.0	2~8	50%~100%	1
16	6.0	2~9	50%~100%	1

- Case 4: ODU is individually connected with hydraulic module

Table 12-4

ODU model (kW)	Capacity of ODU (HP)	Number of hydraulic modules
8	3.0	1
10	3.6	1
12	4.5	1
14	5.0	1
16	6.0	1

⚠ Caution

- When the combination ratio of multiple IDUs exceeds 100%, the air outlet effect of the IDU may deteriorate;
- When the DHW Kit or hydraulic module and the VRF IDU are turned on simultaneously, the air outlet effect of the VRF IDU may deteriorate. At lower ambient temperatures, the DHW kit or hydraulic module shall not be turned on simultaneously with the VRF IDU; either the VRF IDU or hydraulic module (DHW kit) shall be turned on.
- The number of hydraulic modules in a system cannot exceed 1.
- The number of DHW kit(s) in a system cannot exceed 1.
- The DHW kit shall not be separately connected to an ODU.

⚠ Caution

- In areas where the designed temperature of the air conditioner is $\leq 0^{\circ}\text{C}$ in winter and the unit needs to be fully switched on, the combination ratio of IDUs is recommended to not exceed 100%.
- The heating capacity of the system decreases as the ambient outdoor temperature decreases.

13 Unit Installation

13.1 Choosing and Preparing the Installation Site

13.1.1 Unit Dimensions

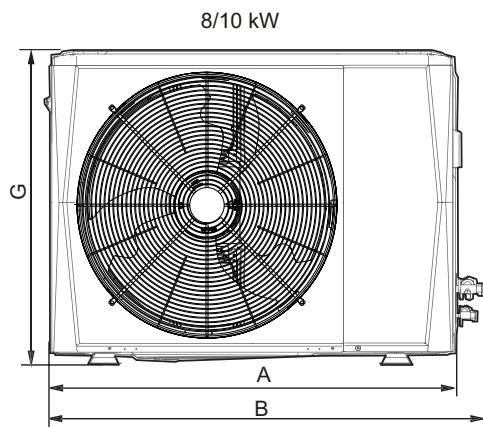

Figure 13-1

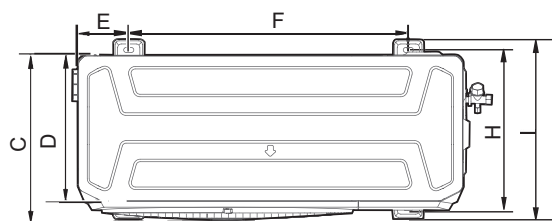

Figure 13-2

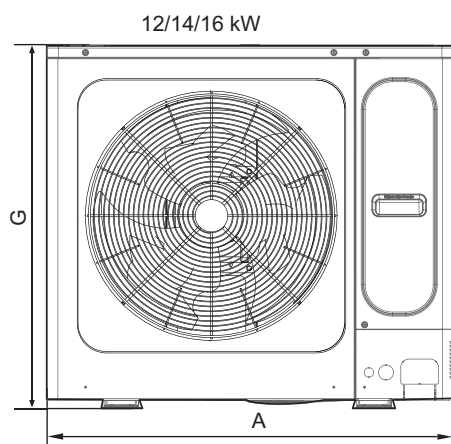

Figure 13-3

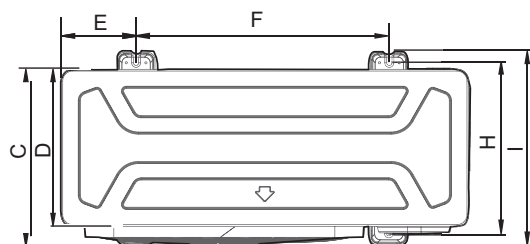

Figure 13-4

Table 13-1 (Unit: mm)

Model	8/10	12/14/16
A	910	950
B	982	/
C	390	406
D	345	360
E	120	175
F	663	590
G	712	840
H	375	390
I	426	440
Drawing No.	Figure 13-1 Figure 13-2	Figure 13-3 Figure 13-4

13.1.2 Placement Consideration

Please keep away from the following places, otherwise unit malfunctions may occur:

- A place with combustible gas leakage.
- A place with lots of oil (including engine oil) compounds.
- A place with salty air (near the coast)
- A place with caustic gas (sulfide, for example) existing in the air (near a hot spring).
- A place where the hot air expelled from the ODU can reach your neighbour's window. A place where the noise interferes your neighbour's everyday life.
- A place that is too weak to bear the weight of the unit. An uneven place. Insufficient ventilation place. A place near a private power station or high frequency equipment. A place where IDU, ODU, power cable and connecting wire are installed at least 1 m away from TV set or radio.
- A place that cannot offer enough space for installation and maintenance. A place that has strict noise requirements.

⚠ Caution

- When an ODU is installed in a place that is regularly exposed to a strong wind like a coastal area or on a high story of a building, ensure normal fan operation by using a duct or an air baffle.
- When installing the ODU in a place that is constantly exposed to strong wind such as the rooftop of a building, apply wind proofing measures like those shown in the following examples. Install the ODU at a place where air discharge is not blocked.

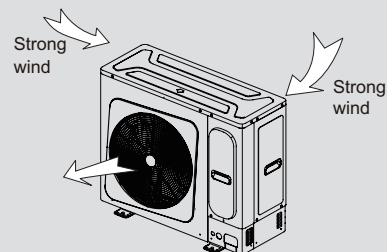

It is recommended that the fan direction of the discharge port be set at right angle to the wind direction.

- Split unit installation

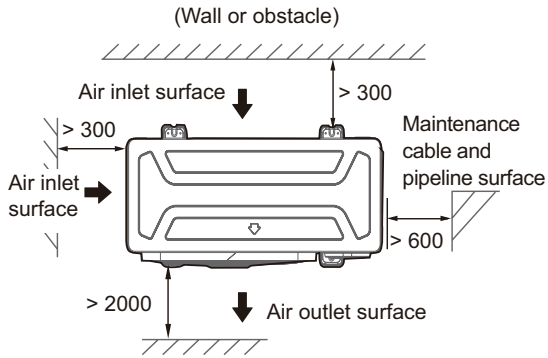

Figure 13-5

- Connect two or more units in parallel

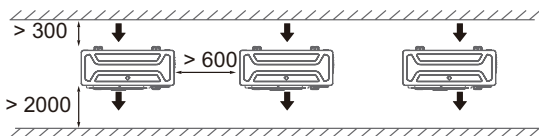

Figure 13-6

- Connect the front and rear parts in parallel

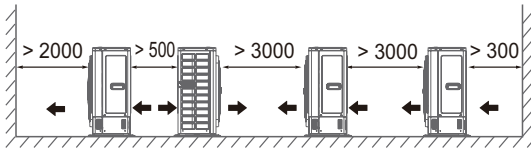
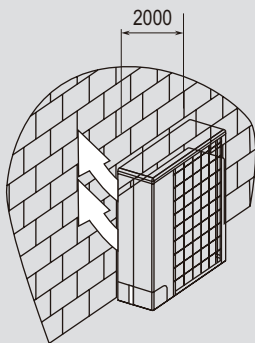

Figure 13-7

Caution

- Keep a distance of 2000 mm or more between the unit and the wall surface when the discharge port faces the wall of the building.



13.1.3 Requirements for ODU Installation in Cold Regions

Protect the ODU from direct snowfall and be careful not to let the ODU become covered in snow.

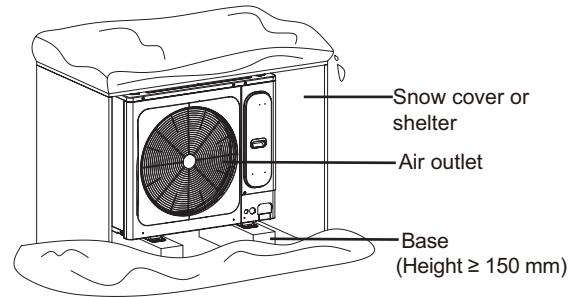

Figure 13-8

Snow may accumulate and freeze between the heat exchanger and the unit casing. This may reduce operational efficiency. For information on how to prevent this after installing the unit, please refer to 13.3.3 Drainage.

13.2 Opening and Closing the Unit

13.2.1 Opening the ODU

Caution

- Risk of electric shock.
- Risk of burns.

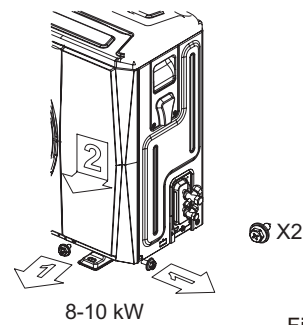

Figure 13-9

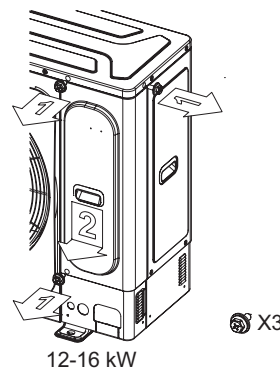

Figure 13-10

13.2.2 Closing the ODU

Caution

Ensure that the tightening torque does not exceed 4.1 N·m when closing the ODU cover.

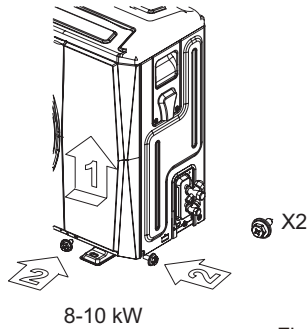

Figure 13-11

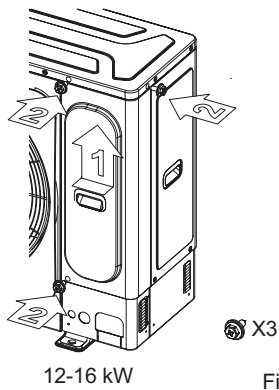

Figure 13-12

13.3 ODU Installation

13.3.1 Preparing the Structure for Installation

Caution

- Ensure that the base does not cover the drain outlet on the unit under the plate or the snow-clearing interfaces (see 13.3.3).
- The recommended height for the protruding part of the upper part of the bolt is 20 mm.

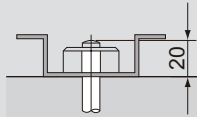

- Fasten the ODU to the foundation bolts using nuts with resin washers.
- If the coating in the fastening area is peeled off, the metal is prone to rusting.

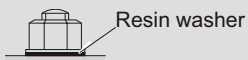

- Build a concrete base according to the specifications of the ODU (see the following figure).
- Prepare four sets of M12 anchor bolts, nuts, and washers (provided on site), as shown in the following figure.

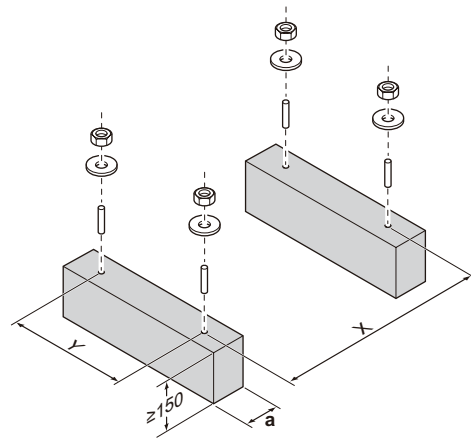

Figure 13-13

Table 13-2

ODU model (kW)	a (mm)	X (mm)	Y (mm)
8/10	≥100	663	375
12/14/16	≥100	584	390

13.3.2 Installing ODU

Fasten the feet of this unit with 4 sets of M12 anchor bolts firmly to prevent it from collapsing in the event of an earthquake or strong winds (refer to the following figure).

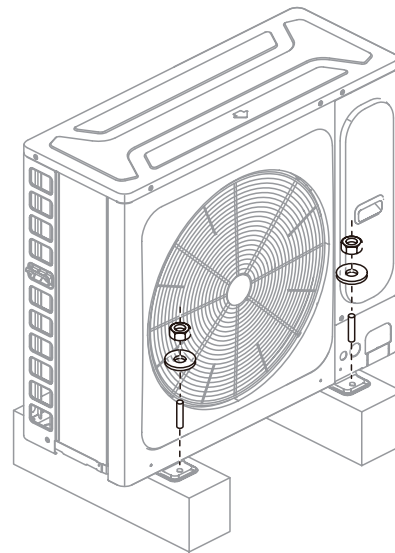
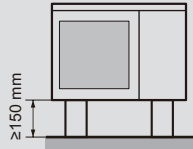

Figure 13-14

13.3.3 Drainage

Caution

- If it is not possible to install the unit completely horizontally, please make sure to tilt towards the back of the unit to ensure smooth drainage.
- If the drain outlet of the ODU is covered by the installation base or floor surface, please raise the unit to a height of at least 150 mm to ensure smooth drainage.



- Drain outlet

Caution

In snowy regions, snow may accumulate and freeze between the heat exchanger and the unit casing. This may reduce operational efficiency.

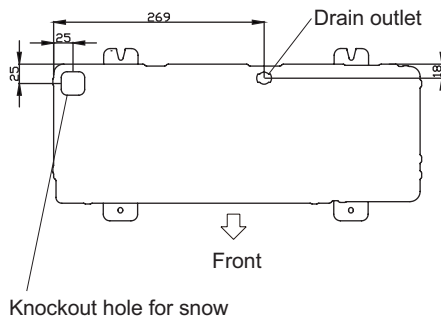

Figure 13-15

13.3.4 Preventing ODUs from Tipping Over

If the unit is installed in a location where strong winds may tilt the unit, please take the following measures:

- Prepare two cables as shown in the following figure (provided on-site).
- Place two cables on the ODU.
- Insert a rubber plate between the cables and the ODU to prevent the cables from scratching the paint (provided on-site).
- Connect both ends of cables.
- Tighten the cables.

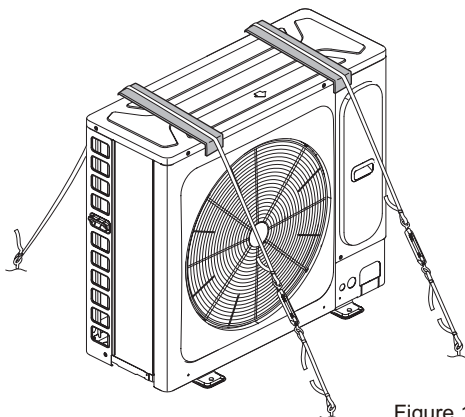

Figure 13-16

14 Installation of Refrigerant Piping

14.1 Selecting and Preparing the Refrigerant Piping

14.1.1 Refrigerant Piping Requirements

Caution

The R32 refrigerant pipeline system must be kept strictly clean, dry and sealed.

- Cleaning and drying: prevent foreign objects (including mineral oil or water) from mixing into the system.
- Seal: R32 does not contain fluorine, does not destroy the ozone layer, and does not deplete the ozone layer that protects the earth from harmful ultraviolet radiation. However, if it is released, R32 can also cause a slight greenhouse effect. Therefore, you must pay special attention when you check the quality of the installation seal.
- The piping and other pressure vessels must comply with the applicable laws and be suitable for use with the refrigerant. Use only phosphoric acid deoxidized seamless copper for the refrigerant piping.
- Foreign objects in the pipes (including lubricant used during pipe bending) must be ≤ 30 mg/10 m.
- Calculate all piping lengths and distances.

14.1.2 Design Considerations

Caution

- The amount of brazing required shall be kept to a minimum.
- As bends cause pressure loss when transporting refrigerant, the fewer bends in the system, the better it is. Piping length needs to take the equivalent length of bends into account (the equivalent length of each branch joint is 0.5 m).
- On the two insides of the first branch joint, the system shall, as much as possible, be equal in terms of the number of units, total capacities and total piping lengths.

14.1.3 Piping and Component Definition

Table 14-1

Description	Pipe connection position	Code
Main pipe	Pipe between the ODU and the first branch joint.	L1
Primary piping of IDU	Pipe between the branch joints.	L2~L5
IDU auxiliary pipe	Pipe between the IDU and the nearest branch joint.	a~f
IDU	DHW kit	N1
	hydraulic module	N1
	VRF IDU	N2~N6

■ Schematic diagram of the allowable length and height difference for refrigerant piping

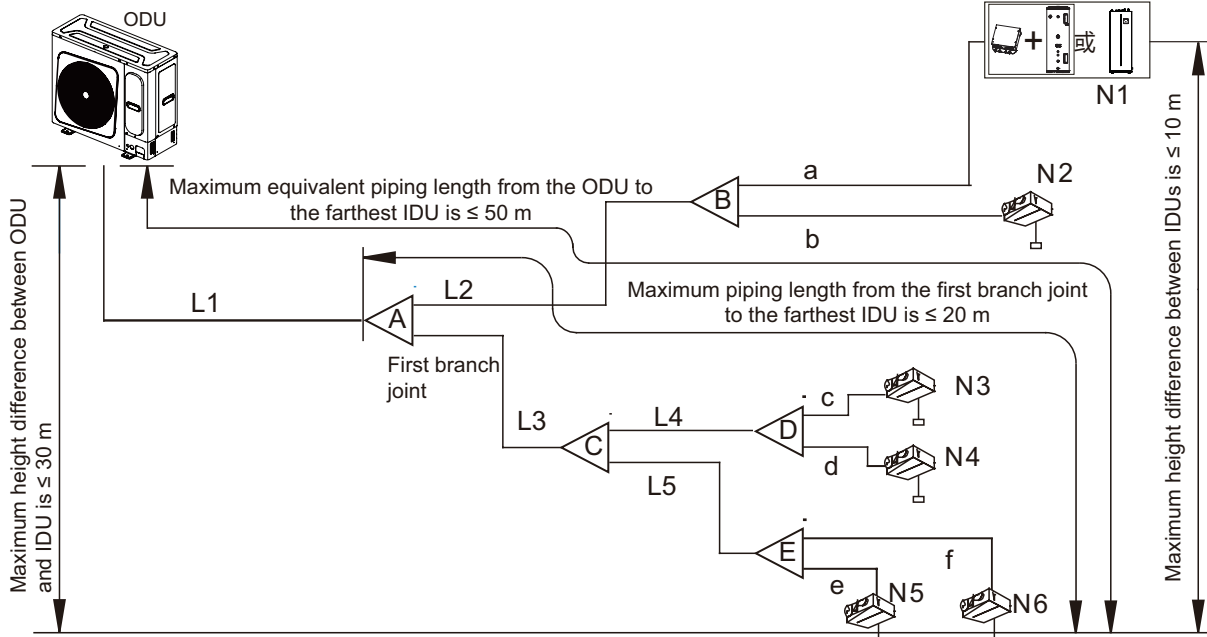

Figure 14-1

14.1.4 Allowable Length and Height Difference for Refrigerant Piping

Table 14-2

		Permitted value	Piping	
Piping Length	Length of refrigerant pipe (actual)	≤ 60 m (8 kW) ≤ 80 m (10/12 kW) ≤ 100 m (14/16 kW)	$L1+L2+L3+L4+L5+a+b+c+d+e+f$	
	Piping length between the ODU and the farthest IDU	Actual length	≤ 35 m (8/10/12 kW) ≤ 45 m (14/16 kW)	$L1+L2+ \max(a,b)$ or $L1+L3+L4+\max(c,d)$ or $L1+L3+L5+\max(e,f)$
		Equivalent length	≤ 40 m (8/10/12 kW) ≤ 50 m (14/16 kW)	
	Piping length between the first branch and the furthest IDU	≤ 20 m	$L2 + \max(a, b, c, d)$ or $L3 + \max(e, f, g, h, i)$	
Piping length between branch joint and hydraulic module or DHW kit	≤ 5 m	a		
Height difference	ODU to IDU	ODU is above	≤ 10 m (8 kW) ≤ 20 m (10/12 kW) ≤ 30 m (14/16 kW)	_____
		ODU is below	≤ 10 m (8/10/12 kW) ≤ 20 m (14/16 kW)	_____
	IDU to IDU	≤ 10 m	_____	

- When the ODU connects only one IDU (DHW kit cannot be independently connected to the ODU)

Table 14-3

Model (kW)	Max height drop (m)		Length of refrigerant pipe (m)	Number of elbows
	ODU on top	ODU at bottom		
8	10	10	20	Less than 10
10	20	20	20	
12	20	20	30	
14	30	20	40	
16	30	20	40	

14.1.5 Refrigerant Pipe Selection

Select refrigerant pipe and branch joint according to Table 14-4 to 14-9.

Caution

- Branch header can also be selected to connect pipes and IDUs. Meanwhile, the relevant requirements in the Installation Manual must be followed.
- The selection of branch header depends on the quantity of branches it connects to.
- Branches and other branch heads cannot be installed downstream of the initial head branch.

Main pipes (L1) and first branch joint (A) according to the ODU

Table 14-4

ODU capacity (kW)	Main pipe size when the total equivalent piping length of liquid + gas side is $i < 90$ m (mm OD)		Branch joint
	Gas pipe (Φ)	Liquid pipe (Φ)	
8~10	Φ15.9	Φ9.52	FQZHN-01D
12~16	Φ15.9	Φ9.52	FQZHN-01D

Table 14-5

ODU capacity (kW)	Main pipe size when the total equivalent piping length of liquid + gas side is ≥ 90 m (mm OD)		Branch joint
	Gas pipe (Φ)	Liquid pipe (Φ)	
8~10	Φ15.9	Φ9.52	FQZHN-01D
12~16	Φ19.1	Φ9.52	FQZHN-01D

Caution

Increase the main gas pipe size when the total equivalent piping length of liquid + gas side is ≥ 90 m, as listed in Table 14-5.

Pipe diameter and branch joints between ODU and IDU according to downstream IDU (DHW kit and hydraulic module need not to be included)

Table 14-6

Total capacity of the downstream IDUs ($\times 100$ W)	IDU main pipe size (mm OD)		Branch joint
	Gas pipe (Φ)	Liquid pipe (Φ)	
$A < 63$	Φ12.7	Φ6.35	FQZHN-01D
$63 \leq A \leq 160$	Φ15.9	Φ9.52	FQZHN-01D
$A > 160$	Φ19.1	Φ9.52	FQZHN-01D

Caution

- The corresponding maximum values listed in Table 14-5, Table 14-6 and Table 14-7 shall be used as the main pipe (L1) size, the first branch joint (A) size and the main pipes (L2-L5) of IDU.
- Choose IDU main pipes and branch joints between the first branch joint and IDUs from the above table in accordance with the total capacity of all the IDUs connected downstream.

IDU auxiliary pipe (a to f)

Table 14-7

IDU type	IDU capacity ($\times 100$ W)	IDU pipe size (mm OD)	
		Gas pipe (Φ)	Liquid pipe (Φ)
VRF IDU	$A < 63$	Φ12.7	Φ6.35
	$63 \leq A \leq 160$	Φ15.9	Φ9.52
DHW kit	-	Φ12.7	Φ6.35
hydraulic module	-	Φ15.9	Φ9.52

Size of ODU stop valve

Table 14-8

ODU model (kW)	Size of ODU stop valve (mm)	
	gas side	liquid side
8	Φ15.9	Φ9.52
10	Φ15.9	Φ9.52
12	Φ15.9	Φ9.52
14	Φ15.9	Φ9.52
16	Φ15.9	Φ9.52

The wall thickness of the refrigerant piping conforms to applicable laws and specifications.

The minimum wall thickness of the R32 piping must be consistent with the table below.

Table 14-9

Piping outer diameter (mm)	Minimum thickness (mm)	Temper grade
ø6.35	0.80	M-type
ø9.52	0.80	M-type
ø12.7	1.00	M-type
ø15.9	1.00	M-type
ø19.1	1.00	M-type
ø22.2	1.00	Y2-type

Caution

- Material: Only seamless phosphorus-deoxidized copper piping that complies with all applicable legislation shall be used.
- Thicknesses: Temper grades and minimum thicknesses for different diameters of piping shall comply with local regulations.
- Design pressure of R32 refrigerant is 4.3 MPa (43 bar).

Example 1 of refrigerant piping selection:

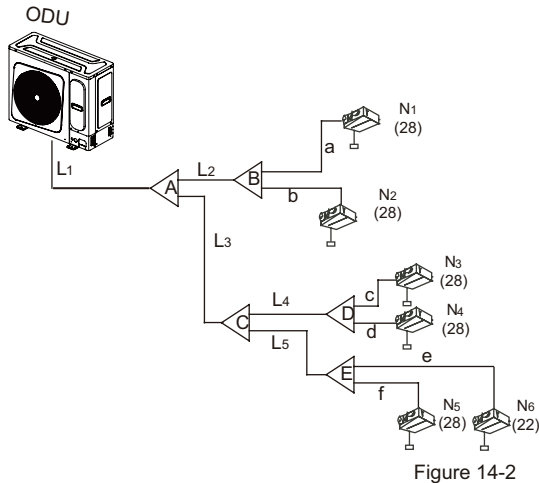

Figure 14-2

The example below illustrates the piping selection procedure for a system consisting of 1 ODU (16 kW) and 6 IDUs (2.2 kW × 1 + 2.8 kW × 5), as shown in Figure 14-2.

The system's total equivalent piping length for all liquid and gas pipes is not more than 90 m.

- Select the main pipe (L1) and first branch joint (A)

The ODU capacity is 16 kW, and the equivalent piping length of all liquid and gas pipes is not greater than 90 m. According to Table 14-4, the gas and liquid pipe sizes are $\Phi 15.9$ and $\Phi 9.52$ respectively. The capacity of the downstream IDUs is 16.2 kW. Then refer to Table 14-6; the main gas/liquid pipe size is $\Phi 19.1/\Phi 9.52$. Referring to the max value principle, the gas and liquid pipe sizes are $\Phi 19.1/\Phi 9.52$ and the first branch joint A is FQZHN-01D.

- Select indoor main pipe (L2 to L5) and branch joint (B to E)

The downstream IDUs of L2 are N1 to N2, with the capacity of 5.6 kW.

Referring to Table 14-6, the gas and liquid pipe sizes of L2 are $\Phi 12.7$ and $\Phi 6.35$ respectively, and the branch joint B is FQZHN-01D.

Similarly, the gas and liquid pipe sizes of L3 are $\Phi 15.9$ and $\Phi 9.52$ respectively, the gas and liquid pipe sizes of L4 and L5 are $\Phi 12.7$ and $\Phi 6.35$ respectively. The branch joints B to E are all FQZHN-01D.

- Select the IDU auxiliary pipe (a to f)

The capacity of IDUs N1 to N6 is all less than 6.3 kW.

According to Table 14-7, the gas and liquid pipe size of a to f are $\Phi 12.7$ and $\Phi 6.35$ respectively.

Example 2 of refrigerant piping selection:

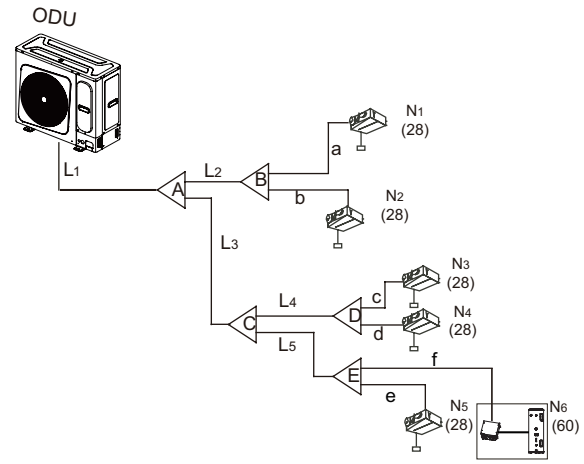

Figure 14-3

The example below illustrates the piping selection procedure for a system consisting of 1 ODU (12 W) and 6 IDUs (5 VRF IDUs (2.8 kW × 5) and 1 DHW kit (6.0 kW × 1)), as shown in Figure 14-3. The system's total equivalent piping length for all liquid and gas pipes is more than 90 m.

- Select the main pipe (L1) and first branch joint (A)

The ODU capacity is 12 kW, and the equivalent piping length of all liquid and gas pipes is not more than 90 m. According to Table 14-5, the gas and liquid pipe sizes are $\Phi 19.1$ and $\Phi 9.52$ respectively. The downstream IDU capacity is 14.0 kW (The DHW kit capacity does not need to be included). Then check Table 14-6 to get the main gas/liquid pipe size of $\Phi 15.9/\Phi 9.52$. According to the maximum value principle, it shall apply the $\Phi 19.1/\Phi 9.52$, and the first branch joint A is FQZHN-01D.

- Select indoor main pipe (L2 to L5) and branch joint (B to E)

The downstream IDUs of L2 are N1 to N2, with the capacity of 5.6 kW. Referring to Table 14-6, the gas and liquid pipe sizes of L2 are $\Phi 12.7$ and $\Phi 6.35$ respectively, and the branch joint B is FQZHN-01D.

Similarly, the gas and liquid pipe sizes of L3 are $\Phi 15.9$ and $\Phi 9.52$ respectively, the gas and liquid pipe sizes of L4 are $\Phi 12.7$ and $\Phi 6.35$ respectively. The downstream IDUs of L5 are N5 to N6, with the capacity of 2.8 kW (The DHW kit capacity does not need to be included). Referring to Table 14-6 and the max value principle, the gas and liquid pipe sizes of L5 are $\Phi 12.7$ and $\Phi 6.35$ respectively, and the branch joint C to E are all FQZHN-01D.

- Select the IDU auxiliary pipe (a to f)

The capacity of IDU N1 to N5 is all less than 6.3 kW.

According to Table 14-7, the gas and liquid pipe sizes of a to e are $\Phi 12.7$ and $\Phi 6.35$ respectively.

According to Table 14-7, the gas and liquid pipe sizes of f are $\Phi 12.7$ and $\Phi 6.35$ respectively.

Example 3 of refrigerant piping selection:

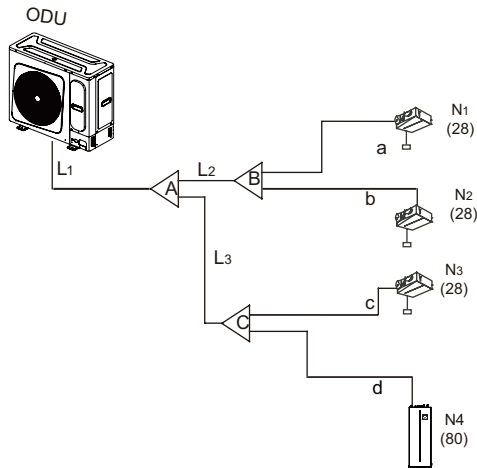

Figure 14-4

The example below illustrates the piping selection procedure for a system consisting of 1 ODU (8 kW) and 4 IDUs (3 VRF IDUs (2.8 kW × 3) and 1 hydraulic module (8.0 kW × 1)), as shown in Figure 14-4.

The system's total equivalent piping length for all liquid and gas pipes is not more than 90 m.

- Select the main pipe (L1) and first branch joint (A)

The ODU capacity is 8 kW, and the equivalent piping length of all liquid and gas pipes is not greater than 90 m.

According to Table 14-4, the main gas liquid pipe size is $\Phi 15.9$ and $\Phi 9.52$ respectively.

The capacity of downstream IDUs is 8.4 kW (The capacity of the hydraulic module does not need to be included).

Then refer to Table 14-6, the main gas/liquid pipe size is $\Phi 15.9/\Phi 9.52$.

Referring to the max value principle, the gas and liquid pipe sizes are $\Phi 15.9/\Phi 9.52$ and the first branch joint A is FQZHN-01D.

- Select the indoor main pipe (L2 to L3) and branch joint (B to C)

The downstream IDUs of L2 are N1 to N2, with the capacity of 5.6 kW. Referring to Table 14-6, the gas and liquid pipe size of L2 are $\Phi 12.7$ and $\Phi 6.35$ respectively, and the branch joint B is FQZHN-01D.

The downstream IDUs of L3 are N5 to N6, with the capacity of 2.8 kW (The capacity of the hydraulic module does not need to be included). Referring to Table 14-6 and the max value principle, the gas and liquid pipe sizes of L3 are $\Phi 15.9$ and $\Phi 9.52$ respectively, and the branch joint C is FQZHN-01D.

- Select the IDU auxiliary pipe (a to d)

The capacity of IDU N1 to N3 is all less than 6.3 kW. According to Table 14-7, the pipe size from a to c is respectively $\Phi 12.7$ and $\Phi 6.35$. According to Table 14-7, the pipe size d is respectively $\Phi 15.9$ and $\Phi 9.52$.

14.2 Connecting Refrigerant Piping

14.2.1 Things to Note When Connecting the Refrigerant Piping

⚠ Caution

- Take appropriate precautions to prevent refrigerant leakage and ventilate the area immediately if the refrigerant leaks, as high concentration of R32 refrigerant in an enclosed area can cause poisoning or fire.
- Refrigerant must be recovered. Do not release it into the environment. Use professional fluorine extraction equipment to extract the refrigerant from the unit.

💡 Caution

- Make sure the refrigerant piping is installed in accordance with applicable laws.
- Make sure the piping and connections are not placed under pressure.
- Before brazing, the refrigerant piping shall be flushed with oxygen free nitrogen (OFN) to remove dust, moisture and other particles. Never use ODU refrigerant.
- Do not open the stop valves until confirming that all the piping connections have been completed and there are no gas leaks in the system.

14.2.2 Refrigerant Piping Connection

💡 Caution

- Please be careful to avoid the components while connecting to the connecting pipes.
- Low temperature solder alloys, such as lead/tin alloys, are not acceptable for pipe connections or any other refrigerant pressure containing purposes.
- Vacuum before welding, if necessary, to ensure that there is no R32 residue in the piping.
- Oxygen free nitrogen (OFN) shall be purged through the system both before and during the brazing process.

14.2.2.1 Outdoor refrigerant piping position

Various piping and wiring patterns can be selected, such as exiting from the front, the back, the side, and bottom, etc. (The following displays the locations of several piping and wiring knock-out holes)

Connection of flaring (8/10 kW)

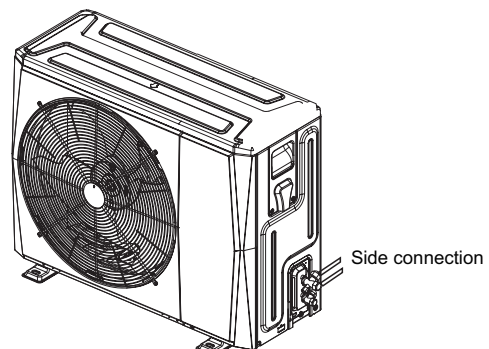

Figure 14-5

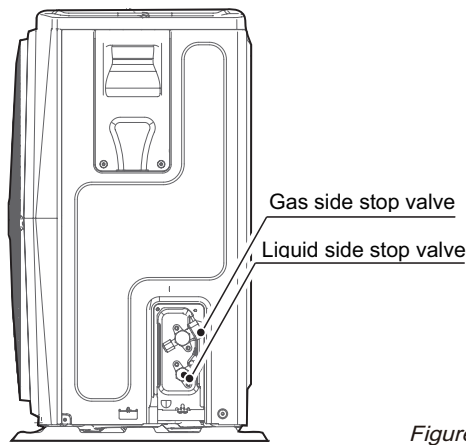

Figure 14-6

The connection method of flaring (12/14/16 kW)

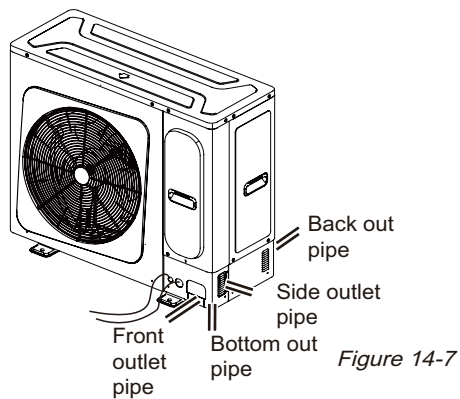

Figure 14-7

Front out pipe connection mode

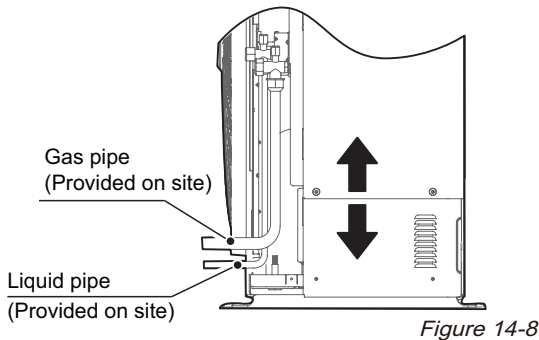

Figure 14-8

Side out pipe connection mode

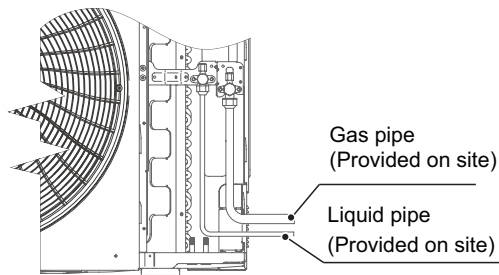

Figure 14-9

Bottom out pipe connection mode

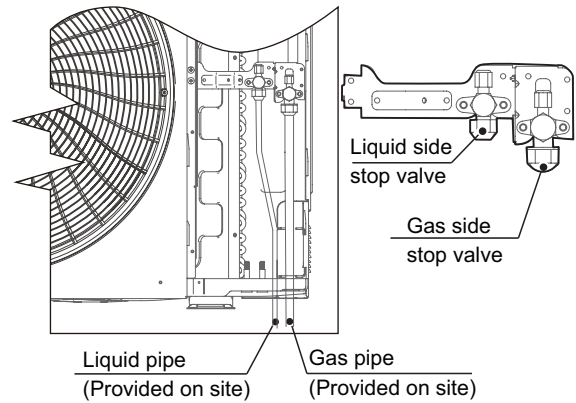

Figure 14-10

Back out pipe connection mode

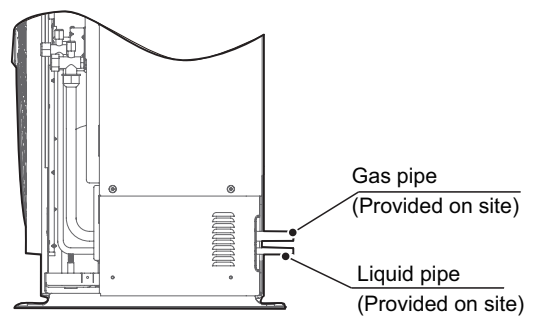

Figure 14-11

⚠ Caution

- Side out pipe: please remove the L shaped metal plate; otherwise, wiring cannot be completed.
- Back out pipe: please wipe off the bracket rubber beside the inner outlet pipe cover of the machine while the pipe exits from the back.
- Front out pipe: cut the frontal hole of the pipe-outlet plate. The method for the out pipe is the same as the back out pipe.

⚠ CAUTION

Bottom out pipe: The knock out shall be from inside to outside, and then piping and wiring shall be fed through this. Make sure that the fat connecting pipe exits through the largest hole, otherwise the pipes will rub together. Please complete moth-proofing for the created hole, to prevent pests from entering the unit and destroying the components

14.2.2.2 Method of piping flaring connection

To cut the piping with a pipe cutter, rotate the pipe cutter repeatedly.

Put the pipe into the connecting nut flaring, and both the gas pipe and liquid pipe of the IDU are connected by flaring.

Align the connecting piping, firstly tighten most of the thread of the connecting nut by hand, and then use a wrench to tighten the last 1-2 turns of the thread as shown in the figure.

The protective nut is a one-time part, it can not be reused. In case it is removed, it should be replaced with a new one.

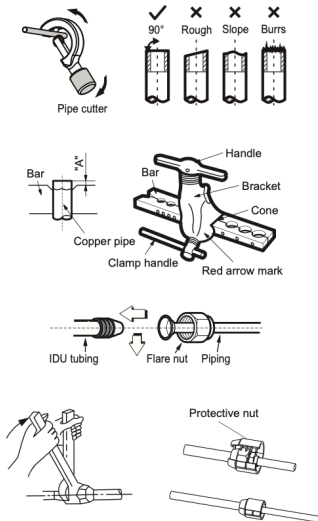

Figure 14-12

Caution

- Excessive torque can break the nut during installation.
- When flared joints are reused indoors, the flaring part shall be re-fabricated.

14.3 Checking Refrigerant Piping

14.3.1 Refrigerant Piping Settings

(See Figure 14-13)

14.3.2 Flushing Pipes

To remove dust, other particles and moisture, which could cause compressor malfunction if not flushed out before the system is run, the refrigerant piping should be flushed using nitrogen. Pipe flushing should be performed once the piping connections have been completed with the exception of the final connections to the indoor units. That is, flushing should be performed once the outdoor units have been connected but before the indoor units are connected.

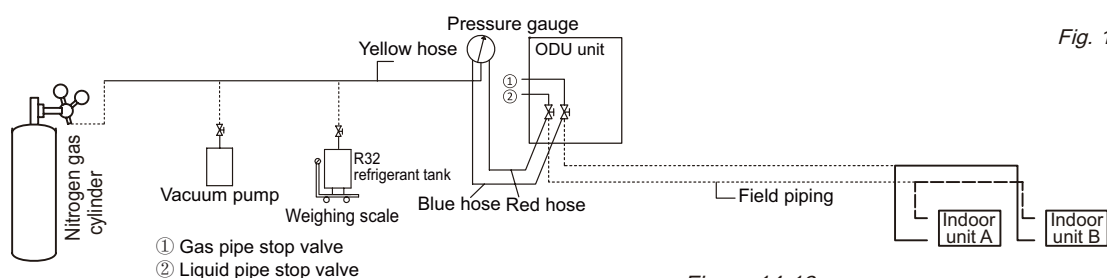

Figure 14-13

CAUTION

Only use nitrogen for flushing. Using carbon dioxide risks leaving condensation in the piping. Oxygen, air, refrigerant, flammable gases and toxic gases must not be used for flushing. Use of such gases may result in fire or explosion.

The liquid and gas sides must be flushed simultaneously.

The flushing procedure is as follows:

1. Cover the inlets and outlets of the indoor units to prevent dirt getting blown in during pipe flushing. (Pipe flushing should be carried out before connecting the indoor units to the piping system.)

2. Attach a pressure reducing valve to a nitrogen cylinder.

3. Connect the pressure reducing valve outlet to the inlet on the liquid (or gas) side of the outdoor unit.

4. Use blind plugs to block all liquid (gas) side openings, except for the opening at the indoor unit which is furthest from the outdoor units ("Indoor unit A" in Fig. 14-14).

5. Start to open the nitrogen cylinder valve and gradually increase the pressure to 0.5Mpa.

6. Allow time for nitrogen to flow as far as the opening at indoor unit A.

7. Flush the first opening:

a) Using suitable material, such as a bag or cloth, press firmly against the opening at indoor unit A.

b) When the pressure becomes too high to block with your hand, suddenly remove your hand allowing gas to rush out.

c) Repeatedly flush in this manner until no further dirt or moisture is emitted from the piping. Use a clean cloth to check for dirt or moisture being emitted. Seal the opening once it has been flushed.

8. Flush the other openings in the same manner, working in sequence from indoor unit A towards the outdoor units. Refer to Fig. 14-15

9. Once flushing is complete, seal all openings to prevent dust and moisture from entering.

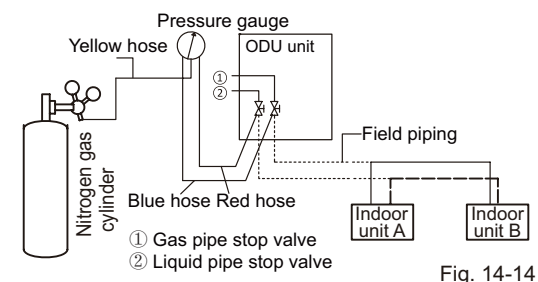

Fig. 14-14

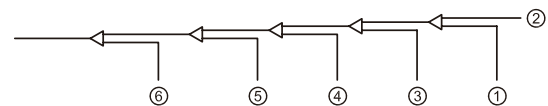

Fig. 14-15

14.3.3 Gas Tightness Test

To prevent faults caused by refrigerant leakage, a gas tightness test should be performed before system commissioning.

CAUTION

- Only dry nitrogen should be used for gas tightness testing. Oxygen, air, flammable gases and toxic gases must not be used for gas tightness testing. Use of such gases may result in fire or explosion.
- Make sure that all the outdoor unit stop valves are firmly closed.
- Make sure all piping connections are complete before the tightness test begins.

The gas tightness test procedure is as follows:

1. Charge the indoor piping with nitrogen at 0.3Mpa through the needle valves on the liquid and gas stop valves and leave for at least 3 minutes (do not open the liquid or gas stop valves). Observe the pressure gauge to check for large leakages. If there is a large leakage, the pressure gauge will drop quickly.

2. If there are no large leakages, charge the piping with nitrogen at 1.5Mpa and leave for at least 3 minutes. Observe the pressure gauge to check for small leakages. If there is a small leakage, the pressure gauge will drop distinctly.

3. If there are no small leakages, charge the piping with nitrogen at 4.2 MPa and leave for at least 24 hours to check for micro leakages. Micro leakages are difficult to detect. To check for micro leakages, allow for any change in ambient temperature over the test period by adjusting the reference pressure by 0.01Mpa per 1°C of temperature difference. Adjusted reference pressure = Pressure at pressurization + (temperature at observation – temperature at pressurization) x 0.01Mpa. Compare the observed pressure with the adjusted reference pressure. If they are the same, the piping has passed the gas tightness test. If the observed pressure is lower than the adjusted reference pressure, the piping has a micro leakage.

4. If the leakage is detected, refer to following part “Leak detection”. Once the leak has been found and fixed, the gas tightness test should be repeated.

5. If not continuing straight to vacuum drying once the gas tightness test is complete, reduce the system pressure to 0.5-0.8MPa and leave the system pressurized until ready to carry out the vacuum drying procedure.

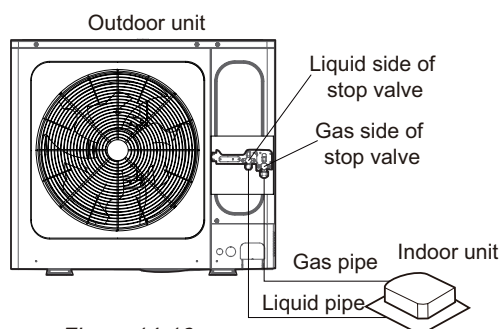

Figure 14-16

14.3.4 Leak Test

The general methods for identifying the source of a leak are as follows:

1. Audio detection: relatively large leaks are audible.
2. Touch detection: place your hand at joints to feel for escaping gas.
3. Soapy water detection: small leaks can be detected by the formation of bubbles when soapy water is applied to a joint.
4. Electronic leak detector detection: electronic leak detector shall be used to check whether air leaks at each joint.

14.3.5 Vacuum Drying

Vacuum drying should be performed in order to remove moisture and non-condensable gases from the system. Removing moisture prevents ice formation and oxidation of copper piping or other internal components. The presence of ice particles in the system would cause abnormal operation, whilst particles of oxidized copper can cause compressor damage. The presence of non-condensable gases in the system would lead to pressure fluctuations and poor heat exchange performance.

Vacuum drying also provides additional leak detection (in addition to the gas tightness test).

NOTE

- Before performing vacuum drying, make sure that all the outdoor unit stop valves are firmly closed.
- Once the vacuum drying is complete and the vacuum pump is stopped, the low pressure in the piping could suck vacuum pump lubricant into the air conditioning system. The same could happen if the vacuum pump stops unexpectedly during the vacuum drying procedure. Mixing of pump lubricant with compressor oil could cause compressor malfunction. Therefore, a check valve should be used to prevent vacuum pump lubricant seeping into the piping system.
- Vacuumize using a vacuum pump. Do not use refrigerant gas to discharge air.
- To prevent the entry of impurities, the R32 special tool must be used to ensure compression strength is maintained. Use a charging hose with a top rod to connect to the access hole of the stop valve or the refrigerant charging port.

During vacuum drying, a vacuum pump is used to lower the pressure in the piping to the extent that any moisture present evaporates. At 5mm Hg (755mm Hg below typical atmospheric pressure) the boiling point of water is 0°C. Therefore, a vacuum pump capable of maintaining a pressure of -756 mm Hg or lower should be used. Using a vacuum pump with a discharge in excess of 4 L/s and a precision level of 0.02mm Hg is recommended. The vacuum drying procedure is as follows:

1. Connect the vacuum pump through a manifold with a pressure gauge to the service port of all stop valves.
2. Start the vacuum pump and then open the manifold valves to start vacuuming the system.
3. Continue vacuum drying for at least 2 hours and until a pressure difference of -0.1 MPa or more has been achieved. Once the pressure difference of at least -0.1 MPa has been achieved, continue vacuum drying for 2 hours. Close the manifold valves and then stop the vacuum pump. After 1 hour, check the pressure gauge. If the pressure in the piping has not increased, the procedure is finished. If the pressure has increased, repeat the steps 1 to 3 until all moisture has been removed.
4. After vacuum drying, keep the manifold connected to the master unit stop valves, in preparation for refrigerant charging.

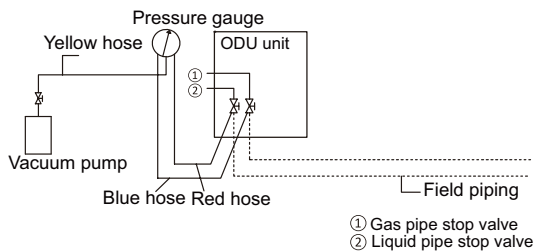

Fig.14-17

14.3.6 Piping Insulation

After the leak test and the vacuum drying are completed, the pipe must be insulated. Considerations:

- Make sure the refrigerant piping and branch joints are completely insulated.
- Make sure the liquid and gas pipes (for all units) are insulated.
- Use heat-resistant polyethylene foam for the liquid pipes (able to withstand temperature of 70°C), and polyethylene foam for the gas pipes (able to withstand temperature of 120°C).
- Reinforce the insulation layer of the refrigerant piping based on the installation environment.

14.3.6.1 Selection of insulation material thickness

Condensed water may form on the surface of the insulation layer.

Table 14-10

Piping size	Humidity<80%RH Thickness	Humidity≥80%RH Thickness
Φ6.35~12.7 mm	≥ 15 mm	≥ 20 mm
Φ15.9~22.2 mm	≥ 20 mm	≥ 25 mm

14.3.6.2 Pipe wrapping

To avoid condensation and water leakage, the connecting pipe must be wrapped with tape to ensure isolation from the air.

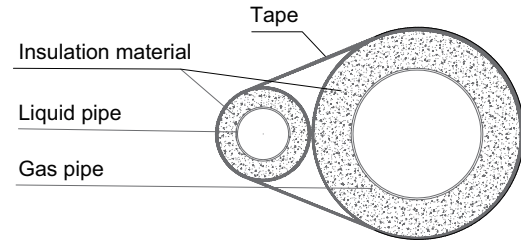

Fig.14-18

When wrapping insulation tape, each circle should press half of the previous circle of tape. Do not wrap the tape too tightly to avoid reducing the thermal insulation effect.

After completing the pipe insulation work, seal the holes in the wall with sealing material.

14.3.6.3 Protective measures of the pipeline

The refrigerant pipe will swing, expand or shrink during operations. If the pipe is not fixed, the load will be concentrated in a certain part, which may cause the deformation or rupture of the refrigerant pipe.

The suspended connecting pipes shall be well supported, and the distance between supports shall not exceed 1m.

The outdoor pipes shall be protected against accidental damage. If the length of the pipe exceeds 1m, a gusset plate must be added for protection.

15 Refrigerant Charging

⚠ WARNING

- Use only R32 as the refrigerant. Other substances may cause explosions and accidents.
- R32 contains fluorinated greenhouse gases, and the GWP value is 675. Do not discharge the gas into the surroundings.
- When charging the refrigerant, make sure you wear protective gloves and safety glasses. Be careful when you open the refrigerant piping.
- Charge the refrigerant only after the system has not failed the gas tightness tests and vacuum drying.
- Ensure that the refrigeration system is earthed prior to charging the system with refrigerant.
- Add the refrigerant amount according to the calculation results. Extreme care shall be taken not to overfill the refrigeration system.
- The system shall be leak tested on completion of charging but prior to commissioning. A follow up leak test shall be carried out prior to leaving the site.

15.1 Calculating Additional Refrigerant Charge

The additional refrigerant charge required depends on the lengths and diameters of the outdoor and indoor liquid pipes and the capacity of the IDU connected. Tables 15-1 to 15-3 show the additional refrigerant charge required under different conditions.

Additional refrigerant charge R1 (according to liquid pipe lengths and diameters)

Table 15-1

Diameter of liquid pipe (mm OD)	Additional refrigerant charge (Equivalent length of liquid pipe per meter) (kg)
Φ6.35	0.019
Φ9.52	0.049
Φ12.7	0.096
Φ15.9	0.153

Additional refrigerant charge (R1) is the sum of additional charges of each outdoor and indoor liquid pipe, as shown in the following formula, where L1 to L4 represent the equivalent length of pipes with different diameters.

Additional refrigerant charge R1 (kg) = L1 (Φ6.35) × 0.019 + L2 (Φ9.52) × 0.049 + L3 (Φ12.7) × 0.096 + L4 (Φ15.9) × 0.153

Additional refrigerant charge R2(Determined by the capacity of VRF IDU connected)

Table 15-2

Capacity of IDU connected (× 1000W)	Additional refrigerant charge per 1000W capacity (kg)
A	0.0238

Additional refrigerant charge R2 = A × 0.0238

Additional refrigerant charge R3(Determined by whether a DHW kit or hydraulic module is connected)

Table 15-3

ODU model (kW)	With DHW kit	With hydraulic module	Additional refrigerant charge (kg)
8	No	Yes	0
10	No	Yes	0
12	No	Yes	0
	Yes	No	0
14	No	Yes	0.333
16	No	Yes	0.380

Table 15-4

Total additional charge (R) is equal to the sum of R1, R2 and R3. Calculate the refrigerant charge according to the following formula:
 $R = R1 + R2 + R3$.

Determine the total refrigerant charge of the system:

Total charge (Mc) = factory charge + additional charge = R0 + R.

The factory charge (R0) can be obtained from Table 15-5.

Table 15-5

Model	Factory charge Refrigerant/kg
8kW	1.4
10kW	1.8
12kW	2.2
14kW	2.4
16kW	2.4

Warning

- The total refrigerant charge of the system, including the factory charge and additional charge, must not exceed the maximum design refrigerant charge of 7.7 kg.

Caution

- The maximum refrigerant charge is related to types of the IDUs, which have different installation heights.
- The actual charges shall not exceed the maximum refrigerant limits of all rooms.
- The maximum refrigerant limit described in Table 1 applies to unventilated areas. For adding additional measures, such as areas with mechanical ventilation, please refer to applicable legislation for the maximum refrigerant limit.

NOTE

- Make sure all connected indoor units have been identified.
- Hoses or lines shall be as short as possible to minimize the amount of refrigerant contained in them.
- Label the system when charging is complete (if it is not already labeled).
- If the power supply of some units is off, the charging program cannot be completed normally.
- Make sure the power supply is turned on 12 hours before operations so that the crankcase heater is properly energized. This is also to protect the compressor.

The procedure for adding refrigerant is as follows:

1. Calculate additional refrigerant charge R (kg).
2. Place a tank of R32 refrigerant on a weighing scale. Turn the tank upside down to ensure refrigerant is charged in a liquid state.
3. After vacuum drying, the blue and red pressure gauge hoses should still be connected to the pressure gauge and to the master unit stop valves.
4. Connect the yellow hose from the pressure gauge to the R32 refrigerant tank.
5. Open the valve where the yellow hose meets the pressure gauge, and open the refrigerant tank slightly to let the refrigerant eliminate the air. Caution: open the tank slowly to avoid freezing your hand.
6. Set the weighing scale to zero.
7. Open the three valves on the pressure gauge to begin charging refrigerant.
8. When the amount charged reaches R (kg), close the three valves. If the amount charged has not reached R (kg) but no additional refrigerant can be charged, close the three valves on the pressure gauge, run the outdoor units in cooling mode, and then open the yellow and blue valves. Continue charging until the full R (kg) of refrigerant has been charged, then close the yellow and blue valves. Note: Before running the system, be sure to complete all the pre-commissioning checks and be sure to open all stop valves as running the system with the stop valves closed would damage the compressor.

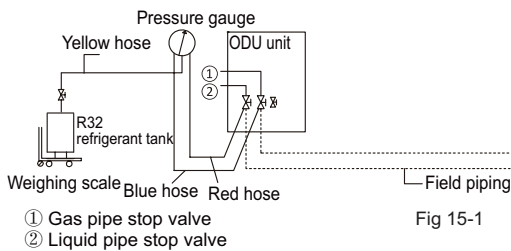

16 Electrical Wiring

16.1 Safety Device Requirements

1. Select the minimum diameter for each unit based on the rated current, as shown in Table 16-1 and Table 16-2.
2. Use a circuit breaker with a spacing between polar contacts of at least 3 mm to ensure full disconnection. MFA is used to select the current circuit breaker and the residual current action circuit breaker.
3. The wire carrying capacity is for reference purposes only. The modification factor of the actual carrying capacity depends on cable type and length, lead-through method, and the environment for cable laying. The user is recommended to modify the factor according to local laws and the installation conditions.
4. The equipment complies with IEC 61000-3-12.

Table 16-1

Rated current of device (A)	Nominal cross-sectional area (mm ²)	
	Soft wire	Cable for fixed wiring
≤ 3	0.5 and 0.75	1~2.5
> 3 and ≤ 6	0.75 and 1	1~2.5
> 6 and ≤ 10	1 and 1.5	1~2.5
> 10 and ≤ 16	1.5 and 2.5	1.5~4
> 16 and ≤ 25	2.5 and 4	2.5~6
> 25 and ≤ 32	4 and 6	4~10
> 32 and ≤ 50	6 and 10	6~16
> 50 and ≤ 63	10 and 16	10~25

⚠ Caution

- A fixed device that is permanently connected to a fixed cable is considered to meet this requirement if the description of the disconnection of the fixed cable satisfies AS/NZS 3000.

Table 16-2

Power supply	Model	ODU				Power supply current			Compressor		Fan motor	
	Capacity (kW)	Voltage (V)	Frequency (Hz)	Minimum (V)	Maximum (V)	Minimum current (rated current) (A)	TOCA (A)	Maximum fuse current (A)	MSC (A)	RLA (A)	Power (kW)	FLA (A)
220-240 V ~ 50 Hz	8	220-240	50	198	264	21.3	18.1	25	-	17.1	0.08	1.0
	10	220-240	50	198	264	29.0	24.0	32	-	22.0	0.08	1.0
	12	220-240	50	198	264	35.0	29.0	40	-	26.5	0.20	1.5
	14	220-240	50	198	264	40.0	33.0	40	-	30.5	0.20	1.5
	16	220-240	50	198	264	40.0	33.0	40	-	30.5	0.20	1.5

Abbreviations:

MCA: minimum current ampacity (A); TOCA: total overcurrent amps (A); MFA: maximum fuse ampere (A); MSC: maximum starting current (A); RLA: rated load amps (A); FLA: full load amps

- The unit is compatible with electrical systems that satisfy the following condition: The voltage supplied to the unit terminal is not lower than or greater than the listed value.
- Select cable specifications according to the MCA value (the rated current in Table 16-1).
- TOCA is the total overcurrent amps of each OC set.
- MFA is used to select the overcurrent circuit breaker and residual current circuit breaker.
- MSC indicates the maximum current upon compressor starting.
- RLA is based on the following conditions: indoor temperature: 27°C DB, 19°C WB; outdoor temperature: 35°C DB.

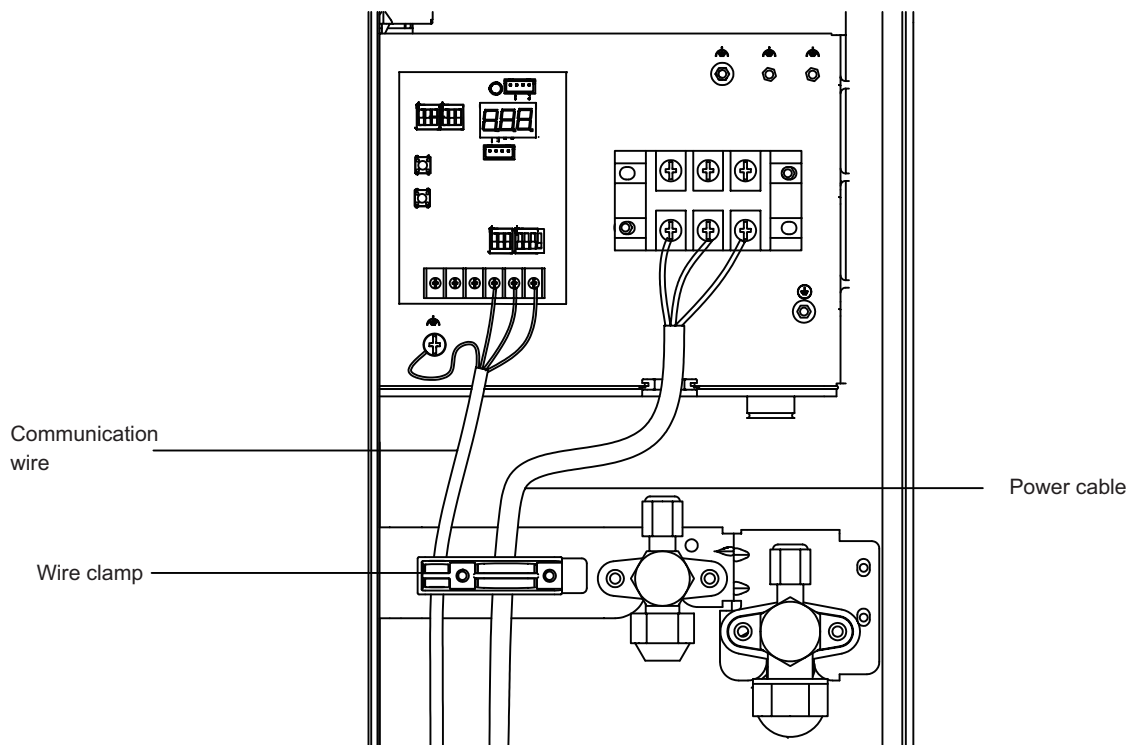

Figure 16-1

⚠ Caution

- If the power supply lacks an N phase or there is an error in the N phase, the device will malfunction.
- Some power equipment may have an inverted phase or intermittent phase (such as a generator). For this type of power source, a reverse-phase protection circuit should be installed locally in the unit, as operating in the inverted phase may damage the unit.
- Do not share the same power supply line with other devices.
- The power cable may produce electromagnetic interference so you should maintain a certain distance from equipment that may be susceptible to such interference.
- Provide separate power supply for the IDU and ODU.

⚠ Warning

- Be careful with the risk of electric shock during installation.
- All the electric wires and components must be installed by a qualified electrician with the proper electrician certification, and the installation process must comply with the applicable regulations.
- Use only wires with copper cores for the connections.
- A main circuit breaker or safety device that can disconnect all polarities must be installed, and it can be completely disconnected when the voltage gets too high.
- Wiring must be carried out in strict accordance with what is stated on the product nameplate.
- Do not squeeze or pull the unit connection, and make sure that the wiring is not in contact with the sharp edges of the sheet metal.
- Ensure that the unit is securely and reliably grounded. Do not connect the ground wire to public pipes, telephone ground wires, surge absorbers and other places that are not designed for grounding. Improper grounding may cause electric shock.
- Make sure the fuses and circuit breakers installed meet the corresponding specifications.
- Ensure that an electric leak protection device is installed to prevent electric shocks or fire.
- The model specifications and characteristics (anti high-frequency noise characteristics) of the electric leak protection device should be compatible with the unit to prevent frequent tripping.
- Before the unit is powered on, make sure the connections between the power cable and terminals of the components are secure, and the metallic cover of the electrical control box is closed tightly.

16.2 Communication Wiring

⚠ Caution

- The PQE electromagnetic interference of communication wires can be mitigated by using more magnetic rings. For installation, see the following figure. Magnetic rings shall be fixed with communication wires (wrapping in one or more rounds) and placed inside the unit to prevent falling.

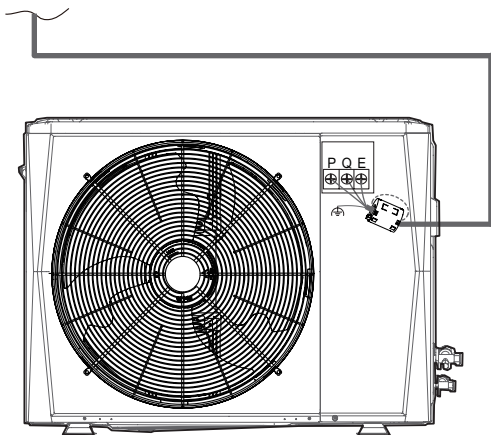
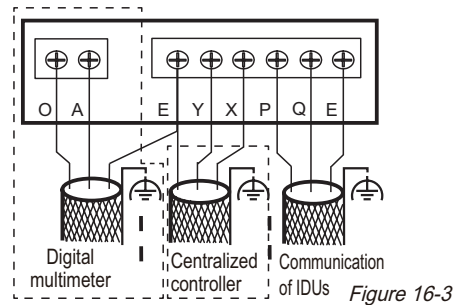

Figure 16-2

- The wiring layout consists of connection cables between ODUs and IDUs (including VRF IDUs, DHW kits and hydraulic modules). It includes the IDU grounding wire and shielding layer in the communication wiring. The ODU Wiring Diagram is shown below.



- This device contains a grounding connection that is for functional purposes only.

Communication wires must conform to safety extra low voltage (SELV) standards.

⚠ Caution

- Do not connect communication wires when the power is on.
- Connect the shielding nets at both ends of the shielded cable to the sheet metal "⊕" of the electrical control box.

⚠ Caution

- On-site wiring must comply with the relevant regulations of the local country/region and must be completed by professionals.
- Communication wires between IDUs (including multiple IDUs, DHW kits and hydraulic modules) and ODUs shall only be led out from ODUs.
- When a single communication wire is not long enough for connection, the joint must be crimped or soldered, and the connected copper wire at the joint shall not be exposed.
- When connecting a power supply cable with a signal cable in parallel, ensure that they are enclosed respectively in their conduits.
- Applicable standards: EN 55014-1 and EN 55014-2. Communication wires must be shielded.
- Do not connect the power cable to the terminal of a communication wire; otherwise, the motherboard will become damaged.

Select a proper method before connecting communication wires. Refer to the following table:

Table 16-3 PQE Communication Mode

Combination	ODU model	Wire type	Number of cores and wire diameter (mm ²)	Total length of communication wire (m)
ODU + IDU	8/10/12/14/16 kW	PVC sheathed copper-core flexible shielded twisted pair	3×0.75	L≤1200
ODU + IDU + DHW kit	12 kW	PVC sheathed copper-core flexible shielded twisted pair	3×0.75	L≤1200
ODU + IDU + hydraulic module	8/10/12/14/16 kW	PVC sheathed copper-core flexible shielded twisted pair	3×0.75	L≤1200
ODU + hydraulic module	8/10/12/14/16 kW	PVC sheathed copper-core flexible shielded twisted pair	3×0.75	L≤1200

- Communication Wiring Diagram (when ODU is only connected with VRF IDU)

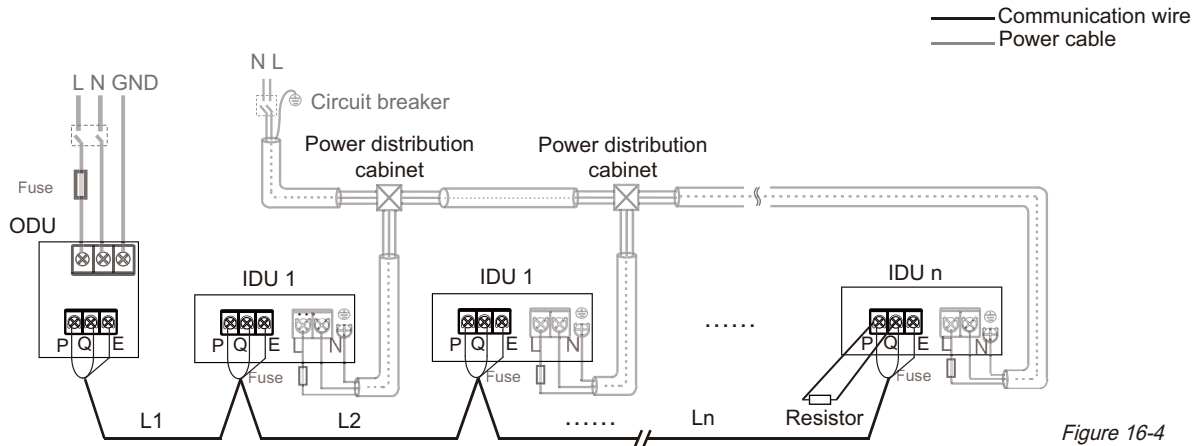

Figure 16-4

⚠ Caution

- $L1 + L2 + Ln \leq 1,200$ m, communication wire 3×0.75 mm².
- After the last IDU, the communication wire should not route back the ODU to form a closed loop.
- Connect a 120ohm resistor between terminals P and Q of the last IDU.
- All communication wires between IDU and ODU must be in serial connection. Shielded cables shall be used. Connect the shielding nets at both ends of the shielded cable to the sheet metal "⚡" of the electrical control box.
- Applicable standards: EN 55014-1 and EN 55014-2.

- Communication Wiring Diagram (when ODU is connected with VRF IDU and DHW kit)

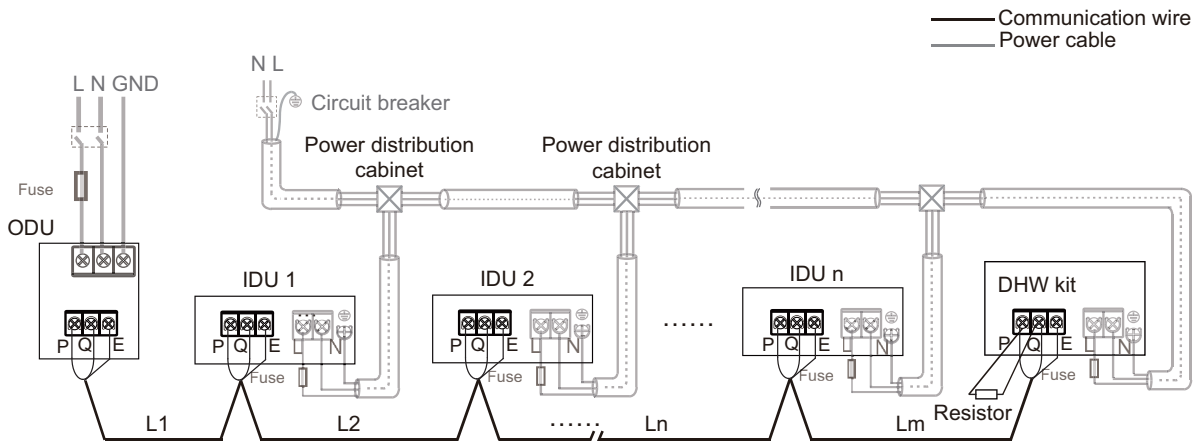

Figure 16-5

⚠ Caution

- $L1 + L2 + Ln + Lm \leq 1,200$ m, communication wire 3×0.75 mm².
- After the last IDU, the communication wire should not route back the ODU to form a closed loop.
- If the system contains a DHW kit, the PQE communication terminals of the ODU and IDU must be in the same order.
- Connect a 120ohm resistor between terminals P and Q of the last IDU.
- All communication wires between IDU and ODU must be in serial connection. Shielded cables shall be used. Connect the shielding nets at both ends of the shielded cable to the sheet metal "⚡" of the electrical control box.
- Applicable standards: EN 55014-1 and EN 55014-2.

- Communication Wiring Diagram (when ODU is connected with VRF IDU and hydraulic module)

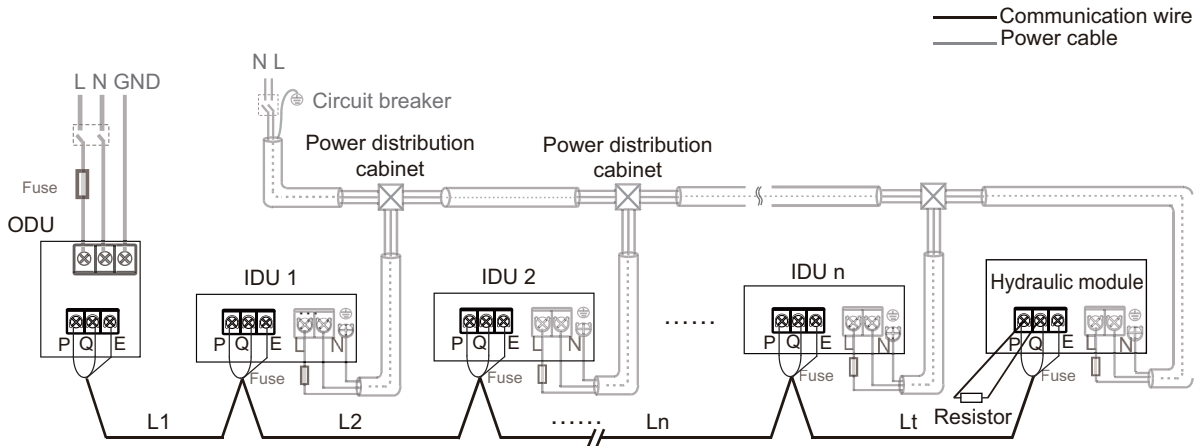

Figure 16-6

⚠ Caution

- $L1 + L2 + Ln + Lt \leq 1,200$ m, communication wire 3×0.75 mm².
- After the last IDU, the communication wire should not route back the ODU to form a closed loop.
- Connect a 120ohm resistor between terminals P and Q of the last IDU.
- All communication wires between IDU and ODU must be in serial connection. Shielded cables shall be used. Connect the shielding nets at both ends of the shielded cable to the sheet metal "⊕" of the electrical control box.
- Applicable standards: EN 55014-1 and EN 55014-2.

- Communication Wiring Diagram (when ODU is only connected with hydraulic module)

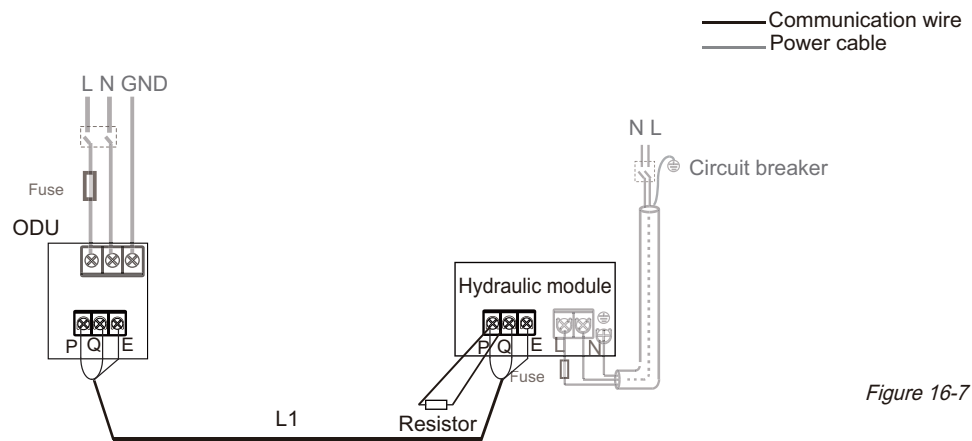

Figure 16-7

⚠ Caution

- $L1 \leq 1,200$ m, communication wiring 3×0.75 mm².
- After the last IDU, the communication wire should not route back the ODU to form a closed loop.
- Connect a 120ohm resistor between terminals P and Q of the last IDU.
- All communication wires between IDU and ODU must be in serial connection. Shielded cables shall be used. Connect the shielding nets at both ends of the shielded cable to the sheet metal "⊕" of the electrical control box.
- Applicable standards: EN 55014-1 and EN 55014-2.

- Communication Wiring Diagram (centralized control and ammeter wiring)

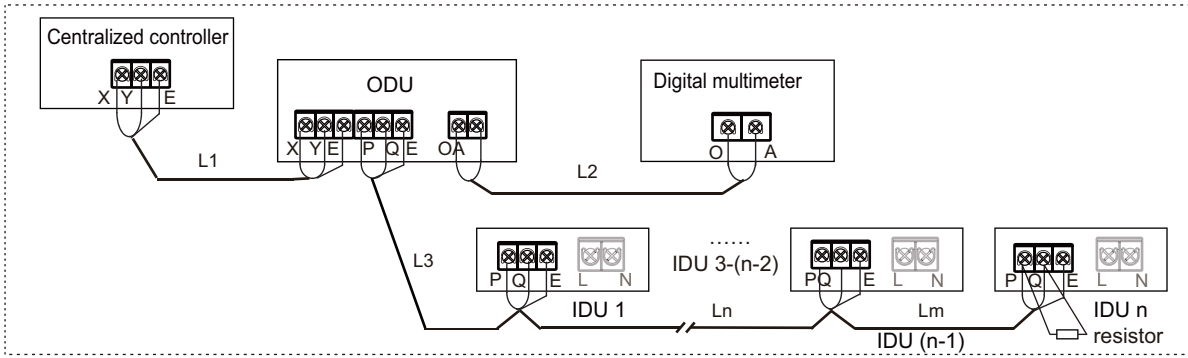

Figure 16-8

⚠ Caution

- $L1 \leq 1,200$ m, $L2 \leq 1,200$ m, $L3 + L_n + L_m \leq 1,200$ m, communication wire $3 \times 0.75\text{mm}^2$.
- All communication wires are shielded. Connect the shielding nets at both ends of the shielded cable to the sheet metal "⊕" of the electrical control box.
- The centralized controller and digital ammeter are optional. Please contact your local distributor to purchase these parts.
- Applicable standards: EN 55014-1 and EN 55014-2.

16.3 Power Cable Connection

⚠ CAUTION

- You must first connect the grounding wire (note that you should use only the yellow-green wire to connect to the ground, and you must turn off the power supply when you are connecting the ground line) before you connect the power cable.
- Before installing the screws, you must first comb through the path along the wiring to prevent any part of the wiring from becoming exceptionally loose or tight due to inconsistencies in the lengths of the power cable and ground line.

The wire diameter must comply with the specification, and make sure the terminal is tight. Do not subject the terminal to any external force.

- Please use the round-type terminal block with the correct specifications to connect the power cables.

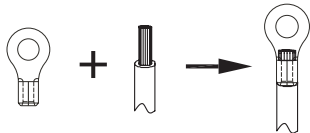
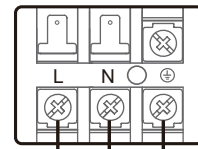

Figure 16-9

⚠ Warning

- Use a coil when inserting the high voltage cable and communication wire into wiring holes to avoid causing wear.
- Do not connect the power supply to the switch module. Otherwise, the whole system may fail.

■ Terminal Block Description



8 kW ODU power supply
220-240 V~ 50 Hz

Figure 16-10

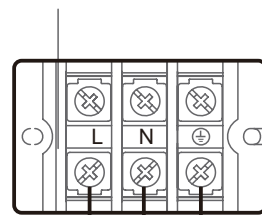

10-16 kW ODU power supply
220-240 V~ 50 Hz

Figure 16-11

17 Configuration

17.1 Overview

This chapter mainly introduces the functions of the ODU check board and other related information.

Including the following information:

- Button function
- DIP setting for priority
- Spot check function enabling

17.2 Functions of SW1 and SW2 Buttons

There are SW1 and SW2 buttons on the ODU check board/main control board, as shown in Figure 17-1. SW1 is for test run and SW2 for checking system parameters.

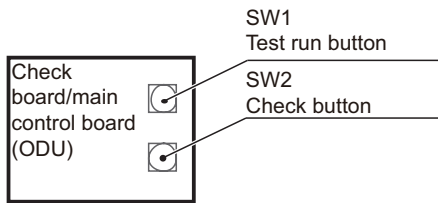

Figure 17-1

Caution

- Operate the switch and button with an insulation rod (such as a ball pen with a cap) or wearing insulation gloves to avoid the contact with energized parts.

17.3 S2 DIP Switch Function

There is an S2 DIP switch on the ODU check board/main control board, as shown in Figure 17-2.

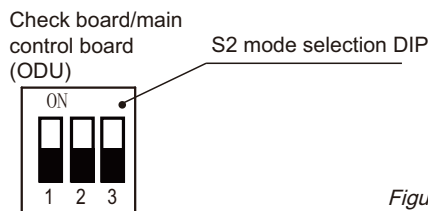

Figure 17-2

Implement priority modes with different DIP combinations. See Table 17-1 for the rules.

S2 Table 17-1

	Automatic selection of priority mode		In response to cooling mode only
	Cooling mode priority		VIP mode priority
	First enabled priority (default)		Heating mode priority
	In response to heating mode only		

17.4 Display Function

There are buttons (8-16 kW for SW2) on the ODU check board/main control board. The digital display on the check board/main control board displays air conditioner parameters in the following order (press the button once to display a parameter).

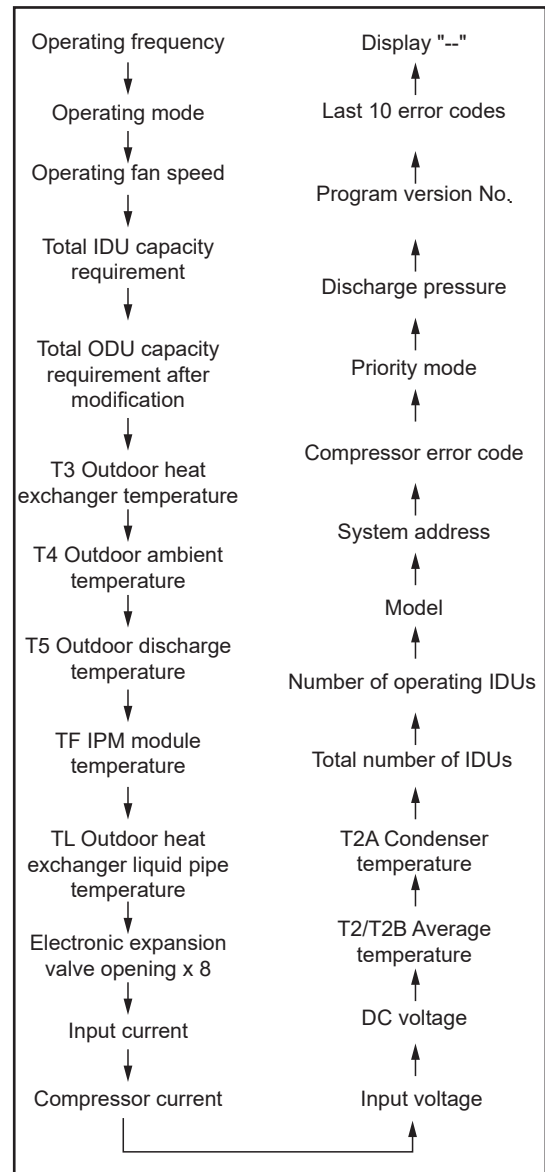

Caution

- T2: Indoor heat exchanger piping temperature
- T2A: Indoor heat exchanger inlet hole temperature
- T2B: Indoor heat exchanger outlet temperature
- T3: Outdoor heat exchanger temperature
- T4: Outdoor ambient temperature
- T5: Discharge temperature
- TF: IPM module temperature
- TL: Outdoor heat exchanger liquid pipe temperature
- EXV: Electronic expansion valve

Caution

Heat up the unit for 12 hours after turning on the power switch. Do not turn off the power supply if the unit is designed to stop within 24 hours or less. (This is for heating up the crankshaft heating box and avoiding forced starting of the compressor.)

Do not block the air inlet and outlet.

Blockage may reduce the unit efficiency or activate the protector to shut down the unit.

Operate the switch and button with an insulation rod (such as a ball pen with a cap) to avoid the contact with energized parts.

18 Commissioning

18.1 Overview

After installation, and once the field settings have been defined, the installation personnel must verify the correctness of the operations. Follow the steps below to perform the test run.

This chapter describes how the test run can be carried out once the installation is complete, and other relevant information.

The test run usually includes the following stages:

1. Review the "Checklist Test Run".
2. Implement the test run.
3. Conduct troubleshooting before the test run is completed with faults, if necessary.
4. Run the system.

18.2 Things to Note During Test Run

Warning

During the test run, the outdoor unit operates at the same time as the indoor units connected to it. It is very dangerous to debug the indoor unit during the test run.

Do not insert fingers, sticks, or other items into the air inlet or outlet. Do not remove the fan mesh cover. If the fan is rotating at a high speed, it may cause bodily injury.

Caution

Note that the required input power may be higher when this unit is run for the first time. This phenomenon is due to the compressor which needs to run for 50 hours before it can achieve a stable operating and power consumption state. Ensure that power has been on for 12 hours and the crankcase heater has been charged correctly before operation. This is a good way to protect the compressor.

Information

A test run can be performed if the ambient temperature is within the range indicated in Figure 18-1.

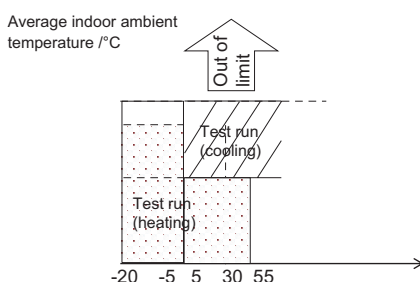

Figure 18-1

18.3 Test Run Checklist

Once this unit is installed, check the following items first. After all following checks have been completed, you must shut down the unit. This is the only way to start the unit again.

Table 18-1

<input type="checkbox"/>	Installation Check if the unit is installed correctly to prevent strange noises and vibrations from occurring when the unit starts.
<input type="checkbox"/>	Field wiring Based on the wiring diagram and the relevant regulations, make sure the field wiring is based on instructions described in Section 16.2 and Section 16.3 on connecting wires.
<input type="checkbox"/>	Grounding wire Make sure the grounding wire is connected correctly, and the grounding terminal is tight.
<input type="checkbox"/>	Insulation test of main circuit Use the megameter of 500 V, apply a voltage of 500 V DC between the power terminal and the grounding terminal. Check that the insulation resistance is above 2 MΩ. Do not use the megameter on the transmission line.
<input type="checkbox"/>	Fuses, circuit breakers, or protection devices Ensure that the fuses, circuit breakers, or locally installed protection devices comply with the size and type specified in "16.1 Requirements for Safety Devices". Make sure you use fuses and protection devices.
<input type="checkbox"/>	Internal wiring Visually inspect if the connections between the electrical component box and the interior of the unit is loose, or if the electrical components are damaged.
<input type="checkbox"/>	Piping dimensions and insulation Make sure the installation piping dimensions are correct, and the insulation work can be carried out normally.
<input type="checkbox"/>	Stop valve Make sure the stop valve is open on both the liquid and gas sides.
<input type="checkbox"/>	Equipment damage Check for damaged components and extruded piping inside the unit.
<input type="checkbox"/>	Refrigerant leak Check the inside of the unit for refrigerant leak. If a leak exists, keep the area ventilated to avoid refrigerant accumulation and eliminate/put out any open flames. Do not touch the refrigerant leaked from the refrigerant piping connection. It may cause frostbite.
<input type="checkbox"/>	Oil leak Check if there is oil leaking from the compressor. If an oil leak occurs, please turn off the power supply and contact the distributor.
<input type="checkbox"/>	Air inlet/outlet Check for paper, cardboard or any other material that may obstruct the air inlet and outlet of the equipment.
<input type="checkbox"/>	Charge additional refrigerant. Indicate the amount of refrigerant to be charged to the unit in the "Confirmation Table" on the front cover of the electrical control box.
<input type="checkbox"/>	Installation date and field settings Record the installation date and field settings.

18.4 About Test Run

18.4.1 Test Run Control

During the test run, the outdoor and indoor units will start at the same time. Make sure all the preparations for the ODU and IDU have been completed.

18.4.2 Test Run Frequency Table 18-2

Model	8-16 kW
Test run frequency (Hz)	44

The following procedures describe the test run of the whole system. This operation checks and determines the following items:

- Check if there is a wiring error (communication with the IDU).
- Check if the stop valve is open.
- Determine the length of the pipe.

18.5 Starting Test Run

There is no test run button SW1 on the ODU check board/main control board. Press the button once to send the test run signal to all ODUs and force all IDUs to run in the cooling mode. Operate the ODUs at a fixed speed given in the table and the IDUs at a high speed. Press the button again to exit the test run.

Caution

System operation parameters are subject to automatic diagnosis during the test run. If the ODU cannot start or stops abnormally during the test run, conduct troubleshooting according to the table of error codes and perform the test run again. If no error code is shown on the ODU digital display, the test run was successful.

18.6 Rectifications after Test Run Is Completed

The test run is considered complete when there is no error code on the user interface or the outdoor unit display. When an error code is displayed, rectify the operation based on the description in the error code table. Try to conduct the test run again to check that the exception has been corrected.

Information

Refer to the installation manual of the indoor unit for details on other error codes related to the indoor unit.

18.7 Operating the Unit

Once the installation of this unit is completed, and the test run of the outdoor and indoor units is complete, you can start to run the system.

The IDU user interface should be connected to facilitate the operations of the IDU. Please refer to the installation manual of the indoor unit for more details.

19 Troubleshooting

19.1 Error Code: Overview

If an error code is displayed on the controller, contact the installation personnel and inform them of the error code, unit model, and serial number (you can find the information on the nameplate of Unit).

Table 19-1 (8/10/12/14/16 kW) Error Codes of ODU

No.	Description	Requiring manual restart	Error code
1	Communication error between main control board and switch module	No	C0
2	System combination fault	Yes	U2
3	Communication error between IDU and ODU	No	E2
4	T3 or T4 temperature sensor error	No	E4
5	Input voltage protection	No	E5
6	DC fan protection	No	E6
7	E6 fault occurring at least 6 times in 1 hour	Yes	Eb
8	EEPROM fault	Yes	E9
9	Wrong compressor parameters	Yes	E.9.
10	PFC feedback resistance fault	Yes	EF
11	Refrigerant radiator temperature sensor fault	No	EH
12	Cooling ambient temperature lower than -16°C	No	EP
13	DC bus voltage protection	No	F1
14	L (L0/L1) fault occurring 3 times in 1 hour	Yes	H4
15	Online IDU quantity decrease/increase	No	H7
16	Radiator surface temperature protection	No	PL
17	System high pressure protection	No	P1
18	System low pressure protection	No	P2
19	Overcurrent protection	No	P3
20	Discharge temperature T5 protection	No	P4
21	Outdoor condenser temperature T3 protection	No	P5
22	4-way valve direction change fault	No	P9
23	IDU evaporator temperature T2 protection	No	PE
24	Abnormal condensation protection	No	Ph
25	Condensation protection	Yes	Pd
26	IPM protection	No	L0
27	DC bus low voltage protection	No	L1
28	DC bus high voltage protection	No	L2
29	Other drive faults	No	L3
30	MCE fault	No	L4
31	Zero speed protection	No	L5
32	Compressor phase sequence fault	No	L7
33	R32 refrigerant leakage	Yes	A3
34	R32 refrigerant leakage sensor error	No	A2

If the problem remains, please contact your distributor or Kaysun's air conditioner customer service center, and provide info about the product model and the fault details.

19.2. Precautions for Refrigerant Leak

Use combustible R32 refrigerant. Ensure the refrigerant is charged in a proper position to cover a large area so that its leak will never reach critical concentration.

Take necessary actions in time.

- Critical concentration-----the max limit concentration of harmless freon
- Critical concentration of refrigerant: R32: 0.25 [kg/m³]

Confirm the critical concentration through the following steps and take necessary measures.

1. Calculate the total charge amount (A[kg]) Total refrigerant amount = refrigerant amount upon delivery + additional refrigerant charge amount
2. Calculate out the outdoor capacity (B[m³]) (as the minimum capacity)
3. Calculate refrigerant concentration

$$\frac{A \text{ [kg]}}{B \text{ [m}^3\text{]}} \leq \text{Critical concentration}$$

Countermeasures for high concentration

1. Install a mechanical ventilation system to reduce the occurrences of refrigerant critical water temperature falling below the critical level. (Regular ventilation)
2. If regular ventilation is not practical, install a leak detection alarm system that is connected to the mechanical ventilator.

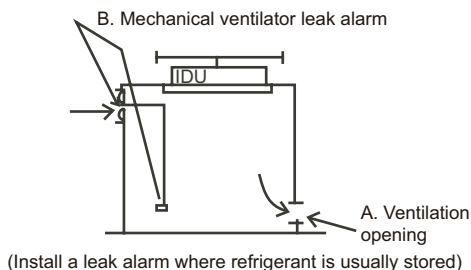
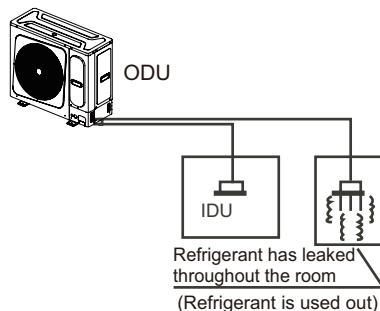

Figure 19-1

Table 19-2

Model	Factory charge	
	Refrigerant/kg	tons of CO2 equivalent
8 kW	1.4	0.95
10 kW	1.8	1.22
12 kW	2.2	1.49
14 kW	2.4	1.62
16 kW	2.4	1.62

⚠ CAUTION

Only certified personnel can install, operate, and maintain the unit.

💡 Caution

- Frequency of refrigerant leak detection
 - 1) For a unit containing fluorinated greenhouse gases of 5 tons of CO₂ equivalent or more, and less than 50 tons of CO₂ equivalent, refrigerant leak detection shall be carried out at least every 12 months, or every 24 months if a leak detection system is installed.
 - 2) For a unit containing fluorinated greenhouse gases of 50 tons of CO₂ equivalent or more, and less than 500 tons of CO₂ equivalent, refrigerant leak detection shall be carried out at least every 6 months, or every 12 months if a leak detection system is installed.
 - 3) For a unit containing fluorinated greenhouse gases of 500 tons of CO₂ equivalent or more, refrigerant leak detection shall be carried out at least every 3 months, or every 6 months if a leak detection system is installed.
 - 4) Non-sealed equipment containing fluorinated gases shall only be sold to end users, with evidence provided that such equipment is installed by certified personnel.

20 Specifications

20.1 Piping Diagram: ODU

■ 8 kW

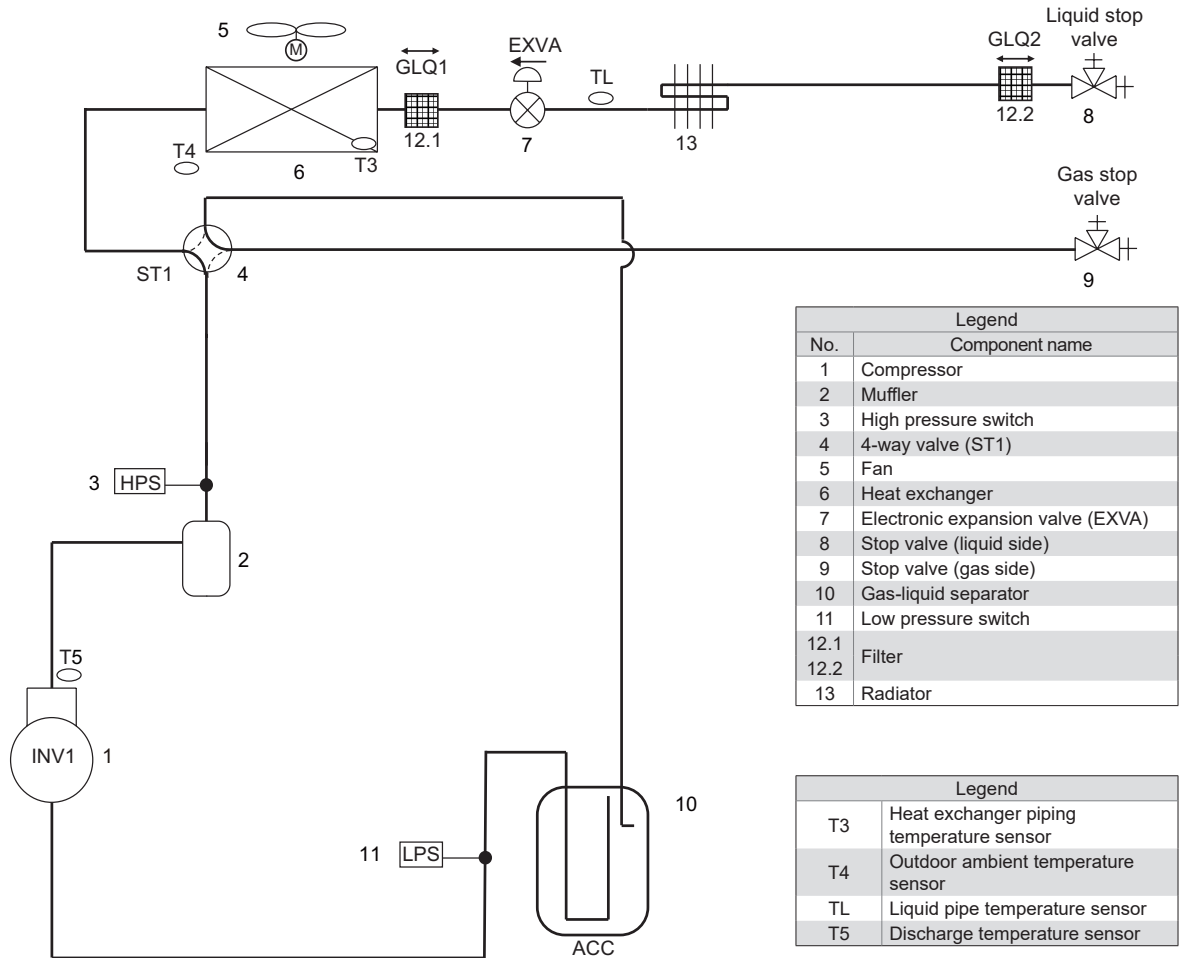

Figure 20-1

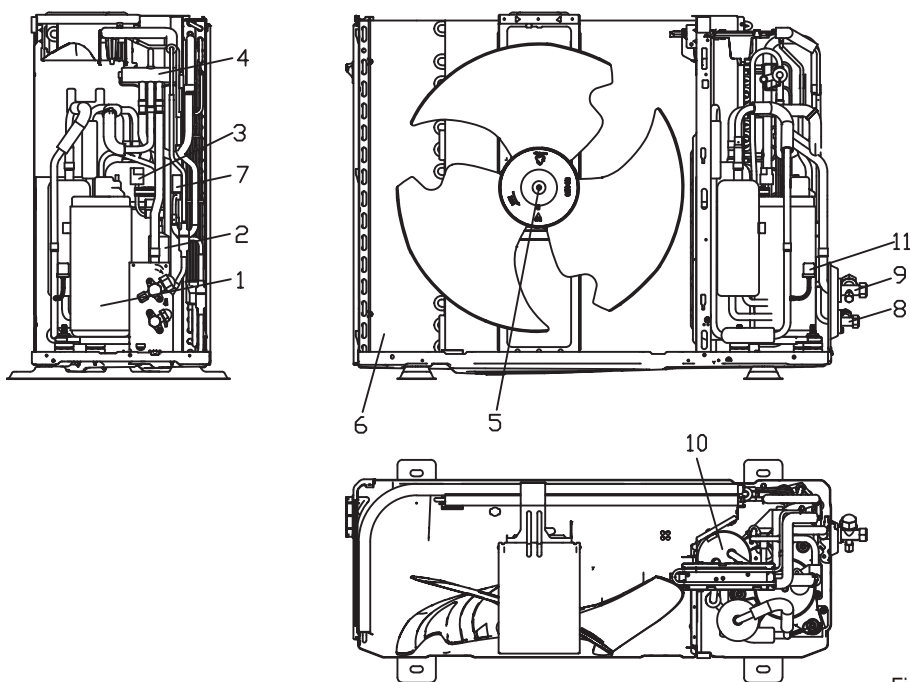

Figure 20-2

■ 10 kW

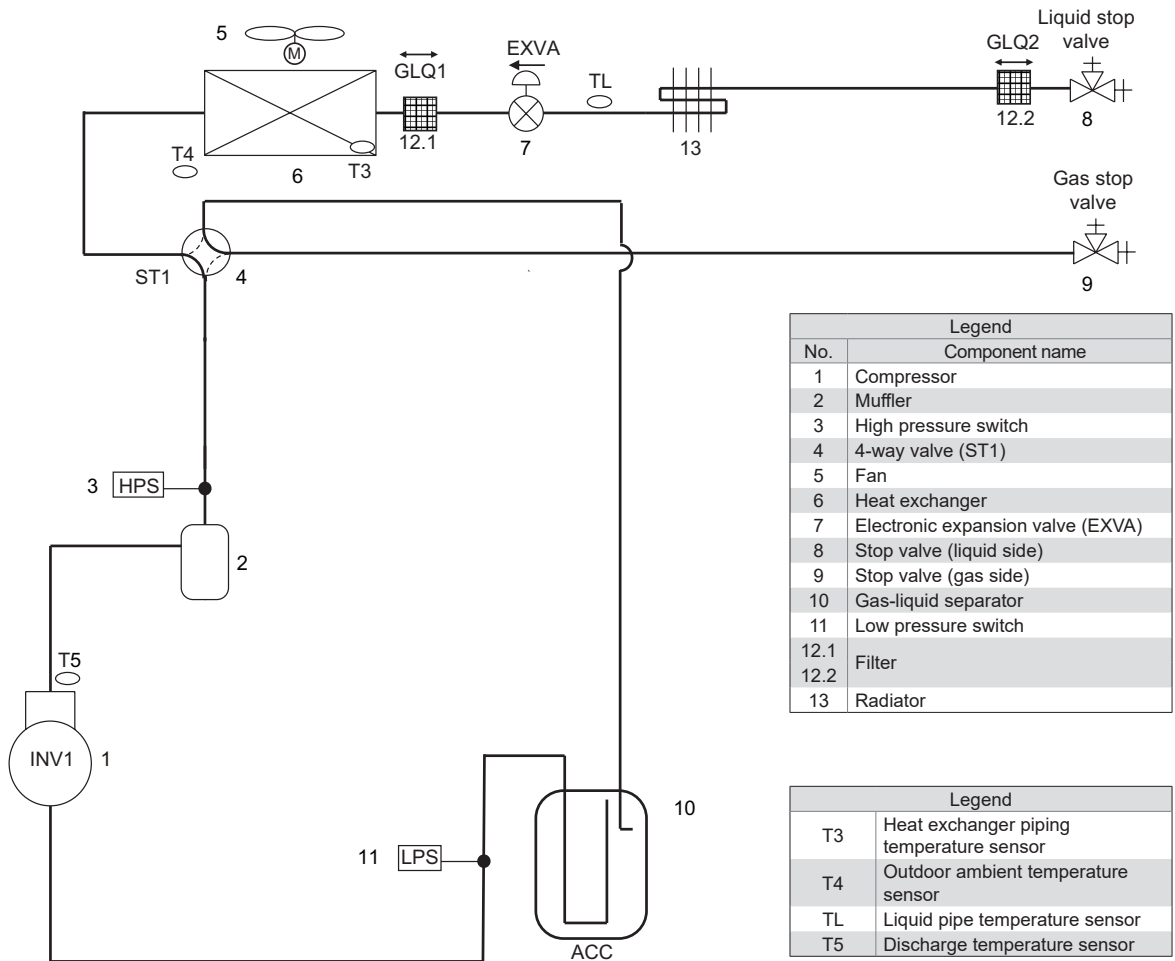

Figure 20-3

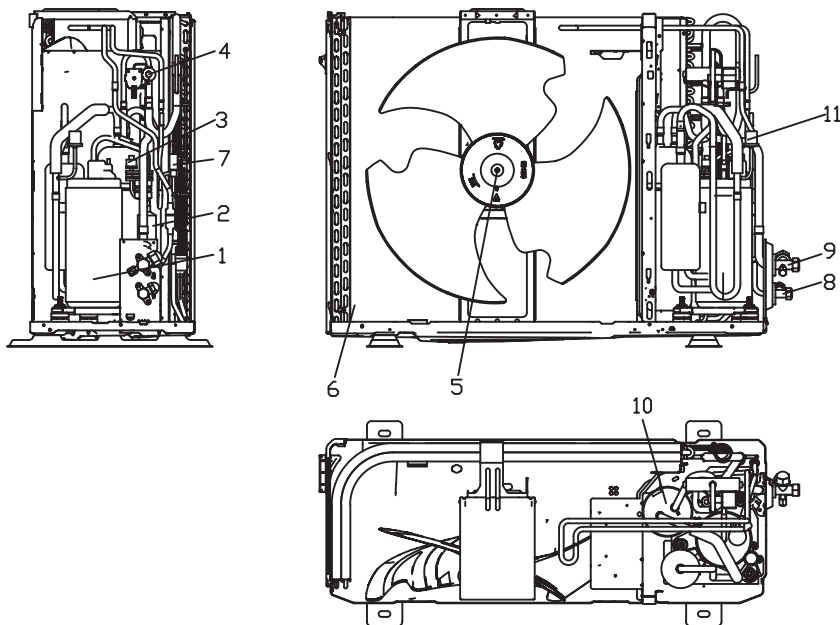

Figure 20-4

■ 12 kW

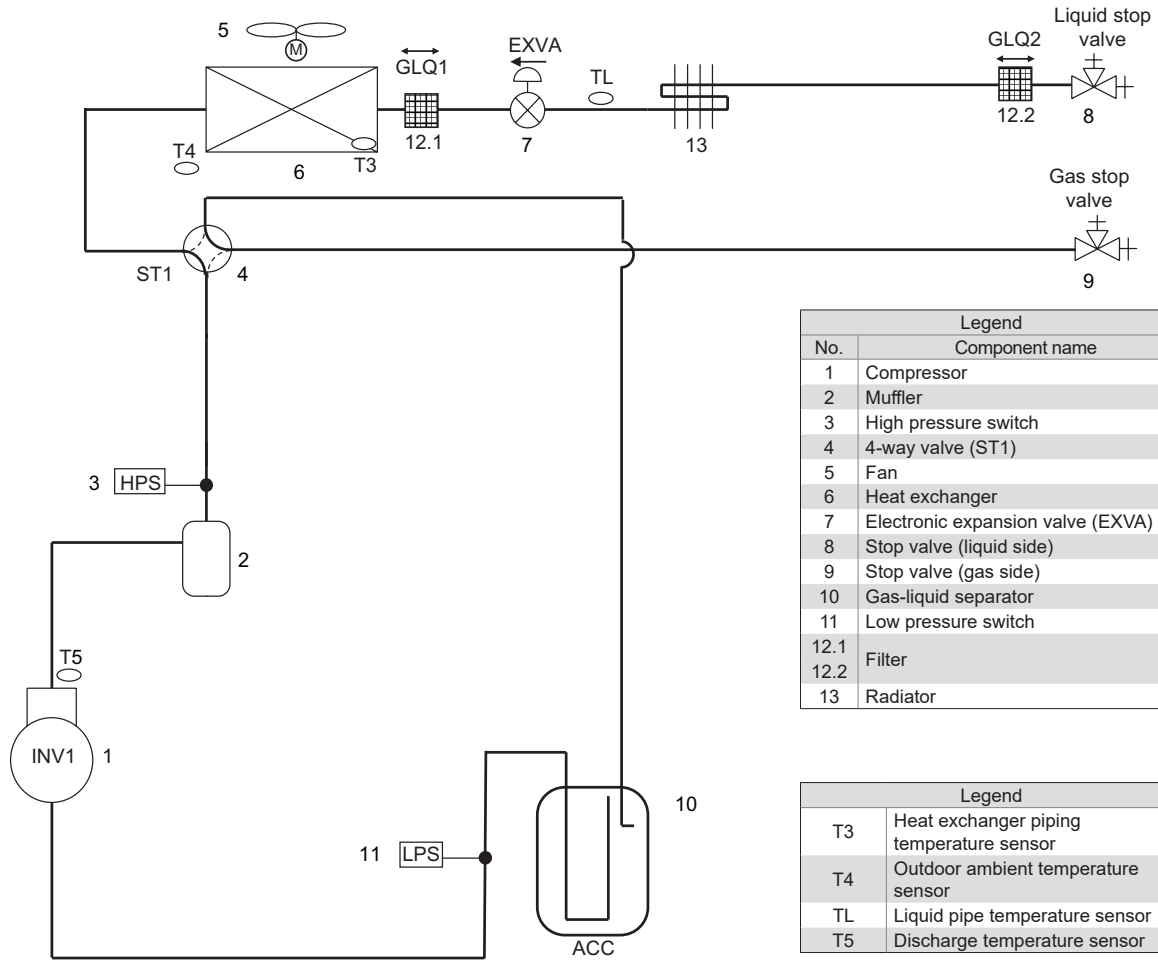

Figure 20-5

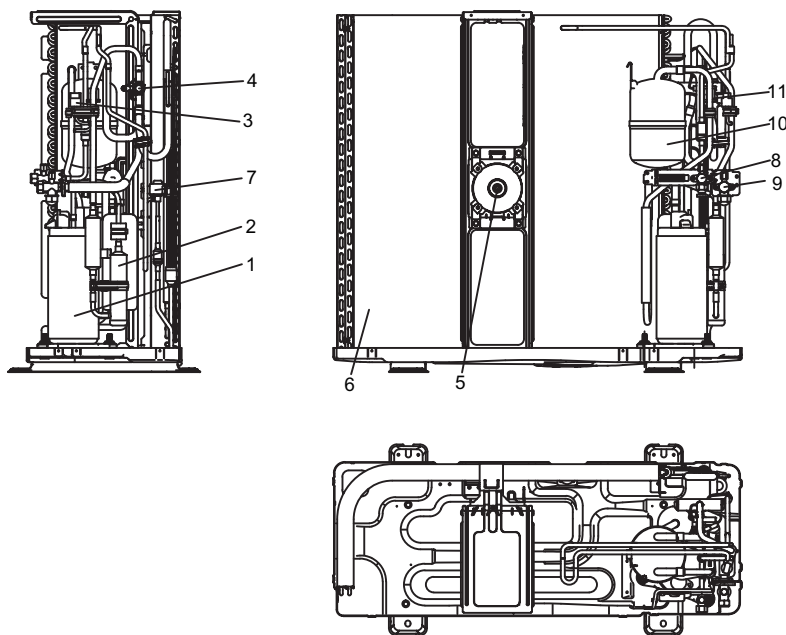

Figure 20-6

■ 14/16 kW

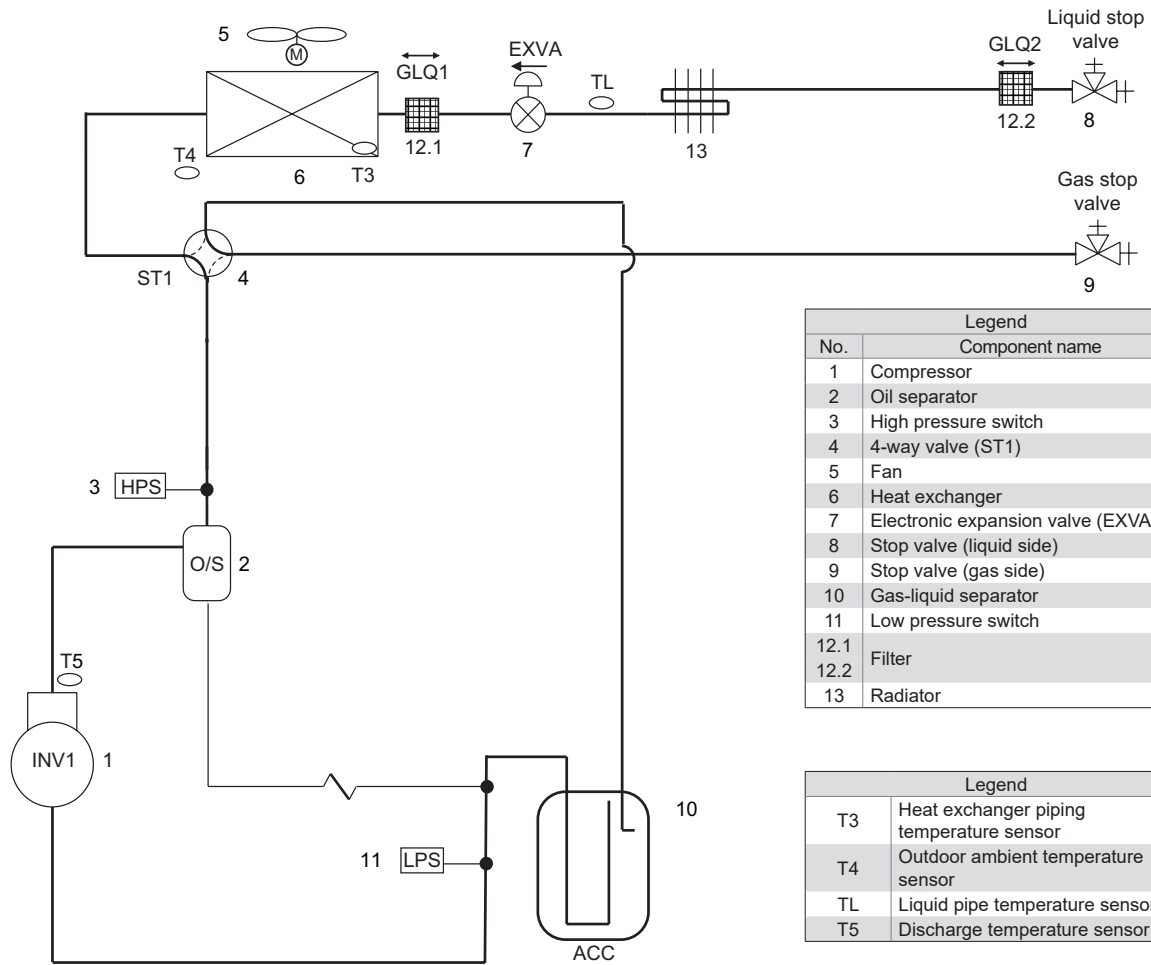

Figure 20-7

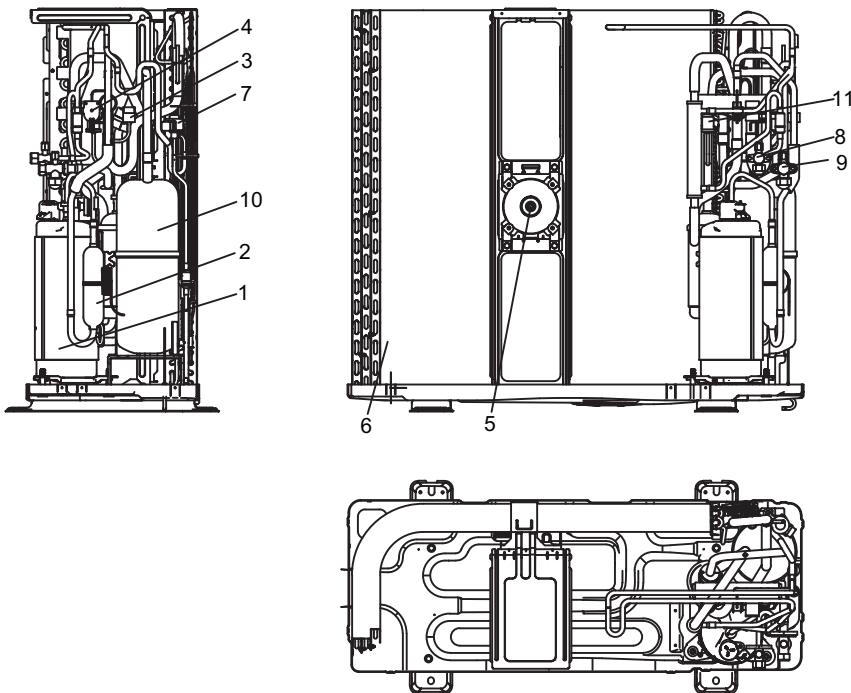

Figure 20-8

21 ERP Information

KMF-80 DVR5

Name or trademark		Factory
Indoor model		1x KCIF-28 DN5.0+1x KCIF-45 DN5.0
Outdoor model		KMF-80 DVR5
Harmonized standards		(EU)206/2012+(EU)2016/2282; (EU)No 626/201+(EU)2C017/254; EN 14825:2016; EN 14511-3:2013; EN 12102-1:2017
Specifics precautions		None
Testing conditions		According to harmonized standards
Sound power level at standard rating conditions (indoor/outdoor)	[dB]	56/66
Refrigerant type		R32
GWP	[kg CO ₂ , equivalents]	675
SEER		5.70
Energy efficiency class in cooling		A
Annual electricity consumption in cooling QCE	[kWh/a]	442
Design load in cooling mode (P _{designc})	[kW]	7.20
SCOP (heating average season)		4.00
Energy efficiency class in heating (average season)		A
Annual electricity consumption in heating QHE (average season)	[kWh/a]	1821
Design load in heating mode (P _{designh})	[kW]	5.20
Declared capacity at reference design condition (heating average season)	[kW]	7.20
Back up heating capacity at reference design condition (heating average season)	[kW]	0
<p>Refrigerant leakage contributes to climate change. Refrigerant with lower global warming potential (GWP) would contribute less to global warming than a Refrigerant with higher GWP, if leaked to the atmosphere. This appliance contains a Refrigerant fluid with a GWP equal to [675]. This means that if 1kg of this refrigerant fluid would be leaked to the atmosphere, the impact on global warming would be [675] times higher than 1kg of CO₂, over a period of 100 years. Never try to interfere with the refrigerant circuit yourself or disassemble the product yourself and always ask a professional.</p>		

KMF-100 DVR5

Name or trademark		Factory
Indoor model		2x KCIF-45 DN5.0
Outdoor model		KMF-100 DVR5
Harmonized standards		(EU)206/2012+(EU)2016/2282; (EU)No 626/201+(EU)2017/254; EN 14825:2016; EN 14511-3:2013; EN 12102-1:2017
Specifics precautions		None
Testing conditions		According to harmonized standards
Sound power level at standard rating conditions (indoor/outdoor)	[dB]	60/68
Refrigerant type		R32
GWP	[kg CO ₂ , equivalents]	675
SEER		5.70
Energy efficiency class in cooling		A
Annual electricity consumption in cooling QCE	[kWh/a]	553
Design load in cooling mode (P _{designc})	[kW]	9.00
SCOP (heating average season)		3.90
Energy efficiency class in heating (average season)		A
Annual electricity consumption in heating QHE (average season)	[kWh/a]	1984
Design load in heating mode (P _{designh})	[kW]	5.60
Declared capacity at reference design condition (heating average season)	[kW]	9.00
Back up heating capacity at reference design condition (heating average season)	[kW]	0
<p>Refrigerant leakage contributes to climate change. Refrigerant with lower global warming potential (GWP) would contribute less to global warming than a Refrigerant with higher GWP, if leaked to the atmosphere. This appliance contains a Refrigerant fluid with a GWP equal to [675]. This means that if 1kg of this refrigerant fluid would be leaked to the atmosphere, the impact on global warming would be [675] times higher than 1kg of CO₂, over a period of 100 years. Never try to interfere with the refrigerant circuit yourself or disassemble the product yourself and always ask a professional.</p>		

KMF-80 DVR5

Cooling mode:

Information requirements for air-to-air conditioners							
Model(s): KMF-80 DVR5							
Test matching indoor units form, no-duct: 1x KCIF-28 DN5.0+1x KCIF-45 DN5.0							
Outdoor side heat exchanger of air conditioner: air							
Indoor side heat exchanger of air conditioner: air							
Type: compressor driven							
Driver of compressor: electric motor							
Item	Symbol	Value	Unit	Item	Symbol	Value	Unit
Rated cooling capacity	$P_{rated,c}$	7.20	kW	Seasonal space cooling energy efficiency	$\eta_{s,c}$	225.0	%
Declared cooling capacity for part load at given outdoor temperatures T_j and indoor 27/19°C (dry/wet bulb)				Declared energy efficiency ratio or gas utilisation efficiency /auxiliary energy factor for part load at given outdoor temperatures T_j			
$T_j=+35^\circ\text{C}$	P_{dc}	7.20	kW	$T_j=+35^\circ\text{C}$	EER_d	3.23	--
$T_j=+30^\circ\text{C}$	P_{dc}	5.31	kW	$T_j=+30^\circ\text{C}$	EER_d	5.30	--
$T_j=+25^\circ\text{C}$	P_{dc}	3.41	kW	$T_j=+25^\circ\text{C}$	EER_d	8.50	--
$T_j=+20^\circ\text{C}$	P_{dc}	3.10	kW	$T_j=+20^\circ\text{C}$	EER_d	9.90	--
Degradation co-efficient for air conditioners(*)							
	C_{dc}	0.25	--				
Power consumption in modes other than "active mode"							
Off mode	P_{OFF}	0.028	kW	Crankcase heater mode	P_{CK}	0.002	kW
Thermosat-off mode	P_{TO}	0.035	kW	Standby mode	P_{SB}	0.028	kW
Other items							
Capacity control	variable			For air-to-air air conditioner: air flow rate, outdoor measured	--	3800	m^3/h
Sound power level, outdoor	LWA	66	dB				
GWP of the refrigerant		675	kg CO ₂ eq (100years)				
Contact details							
(*)If C_{dc} is not determined by measurement, then the default degradation coefficient of heat pumps shall be 0.25.							
Where information relates to multi-split air conditioners, the test result and performance data may be obtained on the basis of performance of the outdoor unit, with a combination of indoor unit(s) recommended by the manufacturer or importer.							

KMF-80 DVR5

Heating mode:

Information requirements for heat pumps								
Model(s): KMF-80 DVR5								
Test matching indoor units form,no-duct: 1x KCIF-28 DN5.0+1x KCIF-45 DN5.0								
Outdoor side heat exchanger of air conditioner: air								
Indoor side heat exchanger of air conditioner: air								
If the heater is equipped with a supplementary heater: no								
Driver of compressor: electric motor								
Parameters shall be declared for the average heating season, parameters for the warmer and colder heating seasons are optional.								
Item	Symbol	Value	Unit		Item	Symbol	Value	Unit
Rated heating capacity	$P_{rated,h}$	7.20	kW		Seasonal space heating energy efficiency	$\eta_{s,h}$	157.0	%
Declared heating capacity for part load at indoor temperature 20°C and outdoor temperatures T_j					Declared coefficient of performance or gas utilisation efficiency/auxiliary energy factor for part load at given outdoor temperatures T_j			
$T_j=-7^\circ\text{C}$	P_{dh}	4.60	kW		$T_j=-7^\circ\text{C}$	COP_d	2.60	--
$T_j=+2^\circ\text{C}$	P_{dh}	2.90	kW		$T_j=+2^\circ\text{C}$	COP_d	3.95	--
$T_j=+7^\circ\text{C}$	P_{dh}	2.30	kW		$T_j=+7^\circ\text{C}$	COP_d	5.43	--
$T_j=+12^\circ\text{C}$	P_{dh}	2.90	kW		$T_j=+12^\circ\text{C}$	COP_d	7.00	--
T_{biv} =bivalent temperature	P_{dh}	5.20	kW		T_{biv} =bivalent temperature	COP_d	2.10	--
T_{oL} =operation temperature	P_{dh}	5.20	kW		T_{oL} =operation temperature	COP_d	2.10	--
Bivalent temperature	T_{biv}	-10	°C					
Degradation coefficient for heat pumps(**)								
	C_{dh}	0.25	--		Supplementary heater			
Power consumption in modes other than "active mode"					Back-up heating capacity(*)			
Off mode	P_{OFF}	0.028	kW		elbu	0	kW	
Thermosat-off mode	P_{TO}	0.035	kW		Type of energy input			
Crankcase heater mode	P_{CK}	0.002	kW		Standby mode	P_{SB}	0.028	kW
Other items								
Capacity control	variable				For air-to-air heat pump: air flow rate, outdoor measured	--	3800	m ³ /h
Sound power level, outdoor	LWA	66	dB					
GWP of the refrigerant		675	kg CO ₂ eq (100years)					
Contact details								
(*)								
(**)If C_{dh} is not determined by measurement, then the default degradation coefficient of heat pumps shall be 0.25.								
Where information relates to multi-split heat pumps, the test result and performance data may be obtained on the basis of performance of the outdoor unit, with a combination of indoor unit(s) recommended by the manufacturer or importer.								

KMF-100 DVR5

Cooling mode:

Information requirements for air-to-air conditioners								
Model(s): KMF-100 DVR5								
Test matching indoor units form,no-duct: 2x KCIF-45 DN5.0								
Outdoor side heat exchanger of air conditioner: air								
Indoor side heat exchanger of air conditioner: air								
Type: compressor driven								
Driver of compressor: electric motor								
Item	Symbol	Value	Unit		Item	Symbol	Value	Unit
Rated cooling capacity	$P_{rated,c}$	9.00	kW		Seasonal space cooling energy efficiency	$\eta_{s,c}$	225.0	%
Declared cooling capacity for part load at given outdoor temperatures T_j and indoor 27/19°C (dry/wet bulb)					Declared energy efficiency ratio or gas utilisation efficiency/auxiliary energy factor for part load at given outdoor temperatures T_j			
$T_j=+35^\circ\text{C}$	P_{dc}	9.00	kW		$T_j=+35^\circ\text{C}$	EER_d	3.06	--
$T_j=+30^\circ\text{C}$	P_{dc}	6.70	kW		$T_j=+30^\circ\text{C}$	EER_d	5.10	--
$T_j=+25^\circ\text{C}$	P_{dc}	4.30	kW		$T_j=+25^\circ\text{C}$	EER_d	7.70	--
$T_j=+20^\circ\text{C}$	P_{dc}	3.37	kW		$T_j=+20^\circ\text{C}$	EER_d	10.50	--
Degradation coefficient for air conditioners(*)								
	C_{dc}	0.25	--					
Power consumption in modes other than "active mode"								
Off mode	P_{OFF}	0.028	kW		Crankcase heater mode	P_{CK}	0.002	kW
Thermosat-off mode	P_{TO}	0.035	kW		Standby mode	P_{SB}	0.028	kW
Other items								
Capacity control	variable				For air-to-air air conditioner: air flow rate, outdoor measured	--	3800	m^3/h
Sound power level, outdoor	LWA	68	dB					
GWP of the refrigerant		675	kg CO ₂ eq (100years)					
Contact details								
(*)If C_{dc} is not determined by measurement, then the default degradation coefficient of heat pumps shall be 0.25.								
Where information relates to multi-split air conditioners, the test result and performance data may be obtained on the basis of performance of the outdoor unit, with a combination of indoor unit(s) recommended by the manufacturer or importer.								

KMF-100 DVR5

Heating mode:

Information requirements for heat pumps							
Model(s): KMF-100 DVR5							
Test matching indoor units form, no-duct: 2x KCIF-45 DN5.0							
Outdoor side heat exchanger of air conditioner: air							
Indoor side heat exchanger of air conditioner: air							
If the heater is equipped with a supplementary heater: no							
Driver of compressor: electric motor							
Parameters shall be declared for the average heating season, parameters for the warmer and colder heating seasons are optional.							
Item	Symbol	Value	Unit	Item	Symbol	Value	Unit
Rated heating capacity	$P_{rated,h}$	9.00	kW	Seasonal space heating energy efficiency	$\eta_{s,h}$	153.0	%
Declared heating capacity for part load at indoor temperature 20°C and outdoor temperatures T_j				Declared coefficient of performance or gas utilisation efficiency/auxiliary energy factor for part load at given outdoor temperatures T_j			
$T_j = -7^\circ\text{C}$	P_{dh}	4.95	kW	$T_j = -7^\circ\text{C}$	COP_d	2.60	--
$T_j = +2^\circ\text{C}$	P_{dh}	3.02	kW	$T_j = +2^\circ\text{C}$	COP_d	3.80	--
$T_j = +7^\circ\text{C}$	P_{dh}	2.40	kW	$T_j = +7^\circ\text{C}$	COP_d	5.60	--
$T_j = +12^\circ\text{C}$	P_{dh}	2.70	kW	$T_j = +12^\circ\text{C}$	COP_d	6.50	--
$T_{biv} = \text{bivalent temperature}$	P_{dh}	5.60	kW	$T_{biv} = \text{bivalent temperature}$	COP_d	2.20	--
$T_{OL} = \text{operation temperature}$	P_{dh}	5.60	kW	$T_{OL} = \text{operation temperature}$	COP_d	2.20	--
Bivalent temperature	T_{biv}	-10	°C				
Degradation coefficient for heat pumps(**)	C_{dh}	0.25	--				
Power consumption in modes other than "active mode"				Supplementary heater			
Off mode	P_{OFF}	0.028	kW	Back-up heating capacity(*)	el_{bu}	0	kW
Thermosat-off mode	P_{TO}	0.035	kW	Type of energy input			
Crankcase heater mode	P_{CK}	0.002	kW	Standby mode	P_{SB}	0.028	kW
Other items							
Capacity control	variable			For air-to-air heat pump: air flow rate, outdoor measured	--	3800	m ³ /h
Sound power level, outdoor	LWA	68	dB				
GWP of the refrigerant		675	kg CO ₂ eq (100years)				
Contact details							
(*)							
(**) If C_{dh} is not determined by measurement, then the default degradation coefficient of heat pumps shall be 0.25.							
Where information relates to multi-split heat pumps, the test result and performance data may be obtained on the basis of performance of the outdoor unit, with a combination of indoor unit(s) recommended by the manufacturer or importer.							

KMF-120 DVR5

Cooling mode:

Information requirements for air-to-air conditioners								
Model(s): KMF-120 DVR5								
Test matching indoor units form,no-duct: 3x KCIF-28 DN5.0+1x KCIF-45 DN5.0								
Outdoor side heat exchanger of air conditioner: air								
Indoor side heat exchanger of air conditioner: air								
Type: compressor driven								
Driver of compressor: electric motor								
Item	Symbol	Value	Unit		Item	Symbol	Value	Unit
Rated cooling capacity	$P_{rated,c}$	12.30	kW		Seasonal space cooling energy efficiency	$\eta_{s,c}$	297.0	%
Declared cooling capacity for part load at given outdoor temperatures T_j and indoor 27/19°C (dry/wet bulb)					Declared energy efficiency ratio or gas utilisation efficiency/auxiliary energy factor for part load at given outdoor temperatures T_j			
$T_j=+35^\circ\text{C}$	P_{dc}	12.30	kW		$T_j=+35^\circ\text{C}$	EER_d	3.20	--
$T_j=+30^\circ\text{C}$	P_{dc}	9.00	kW		$T_j=+30^\circ\text{C}$	EER_d	5.20	--
$T_j=+25^\circ\text{C}$	P_{dc}	5.80	kW		$T_j=+25^\circ\text{C}$	EER_d	10.00	--
$T_j=+20^\circ\text{C}$	P_{dc}	4.10	kW		$T_j=+20^\circ\text{C}$	EER_d	15.00	--
Degradation co-efficient for air conditioners(*)								
	C_{dc}	0.25	--		Power consumption in modes other than "active mode"			
Off mode	P_{OFF}	0.028	kW		Crankcase heater mode	P_{CK}	0.002	kW
Thermosat-off mode	P_{TO}	0.005	kW		Standby mode	P_{SB}	0.028	kW
Other items								
Capacity control	variable				For air-to-air air conditioner: air flow rate, outdoor measured	--	5200	m^3/h
Sound power level, outdoor	LWA	71	dB					
GWP of the refrigerant		675	$\text{kg CO}_2 \text{ eq (100years)}$					
Contact details								
(*)If C_{dc} is not determined by measurement, then the default degradation coefficient of heat pumps shall be 0.25.								
Where information relates to multi-split air conditioners, the test result and performance data may be obtained on the basis of performance of the outdoor unit, with a combination of indoor unit(s) recommended by the manufacturer or importer.								

KMF-120 DVR5

Heating mode:

Information requirements for heat pumps								
Model(s): KMF-120 DVR5								
Test matching indoor units form,no-duct: 3x KCIF-28 DN5.0+1x KCIF-45 DN5.0								
Outdoor side heat exchanger of air conditioner: air								
Indoor side heat exchanger of air conditioner: air								
If the heater is equipped with a supplementary heater: no								
Driver of compressor: electric motor								
Parameters shall be declared for the average heating season, parameters for the warmer and colder heating seasons are optional.								
Item	Symbol	Value	Unit		Item	Symbol	Value	Unit
Rated heating capacity	P _{rated,h}	12.30	kW		Seasonal space heating energy efficiency	η _{s,h}	173.0	%
Declared heating capacity for part load at indoor temperature 20°C and outdoor temperatures T _j					Declared coefficient of performance or gas utilisation efficiency/auxiliary energy factor for part load at given outdoor temperatures T _j			
T _j =-7°C	P _{dh}	6.90	kW		T _j =-7°C	COP _d	2.60	--
T _j =+2°C	P _{dh}	4.20	kW		T _j =+2°C	COP _d	4.15	--
T _j =+7°C	P _{dh}	2.90	kW		T _j =+7°C	COP _d	6.40	--
T _j =+12°C	P _{dh}	2.90	kW		T _j =+12°C	COP _d	8.75	--
T _{biv} =bivalent temperature	P _{dh}	7.80	kW		T _{biv} =bivalent temperature	COP _d	2.10	--
T _{oL} =operation temperature	P _{dh}	7.80	kW		T _{oL} =operation temperature	COP _d	2.10	--
Bivalent temperature	T _{biv}	-10	°C					
Degradation coefficient for heat pumps(**)								
	C _{dh}	0.25	--		Supplementary heater			
Power consumption in modes other than "active mode"					Back-up heating capacity(*)			
Off mode	P _{OFF}	0.028	kW		elbu	0	kW	
Thermosat-off mode	P _{TO}	0.028	kW		Type of energy input			
Crankcase heater mode	P _{CK}	0.002	kW		Standby mode	P _{SB}	0.028	kW
Other items								
Capacity control	variable				For air-to-air heat pump: air flow rate, outdoor measured	--	5200	m ³ /h
Sound power level, outdoor	L _{WA}	71	dB					
GWP of the refrigerant		675	kg CO ₂ eq (100years)					
Contact details								
(*)								
(**)If C _{dh} is not determined by measurement, then the default degradation coefficient of heat pumps shall be 0.25.								
Where information relates to multi-split heat pumps, the test result and performance data may be obtained on the basis of performance of the outdoor unit, with a combination of indoor unit(s) recommended by the manufacturer or importer.								

KMF-140 DVR5

Cooling mode:

Information requirements for air-to-air conditioners								
Model(s): KMF-140 DVR5								
Test matching indoor units form,no-duct: 2x KCIF-28 DN5.0+2x KCIF-45 DN5.0								
Outdoor side heat exchanger of air conditioner: air								
Indoor side heat exchanger of air conditioner: air								
Type: compressor driven								
Driver of compressor: electric motor								
Item	Symbol	Value	Unit		Item	Symbol	Value	Unit
Rated cooling capacity	P _{rated,c}	14.00	kW		Seasonal space cooling energy efficiency	η _{s,c}	273.0	%
Declared cooling capacity for part load at given outdoor temperatures T _j and indoor 27/19°C (dry/wet bulb)					Declared energy efficiency ratio or gas utilisation efficiency/auxiliary energy factor for part load at given outdoor temperatures T _j			
T _j =+35°C	P _{dc}	14.00	kW		T _j =+35°C	EER _d	3.23	--
T _j =+30°C	P _{dc}	10.30	kW		T _j =+30°C	EER _d	5.30	--
T _j =+25°C	P _{dc}	6.60	kW		T _j =+25°C	EER _d	9.10	--
T _j =+20°C	P _{dc}	6.00	kW		T _j =+20°C	EER _d	11.10	--
Degradation coefficient for air conditioners(*)								
	C _{dc}	0.25	--					
Power consumption in modes other than "active mode"								
Off mode	P _{OFF}	0.028	kW		Crankcase heater mode	P _{CK}	0.002	kW
Thermosat-off mode	P _{TO}	0.005	kW		Standby mode	P _{SB}	0.028	kW
Other items								
Capacity control	variable				For air-to-air air conditioner: air flow rate, outdoor measured	--	5000	m ³ /h
Sound power level, outdoor	LWA	70	dB					
GWP of the refrigerant		675	kg CO ₂ eq (100years)					
Contact details								
(*)If C _{dc} is not determined by measurement, then the default degradation coefficient of heat pumps shall be 0.25.								
Where information relates to multi-split air conditioners, the test result and performance data may be obtained on the basis of performance of the outdoor unit, with a combination of indoor unit(s) recommended by the manufacturer or importer.								

KMF-140 DVR5

Heating mode:

Information requirements for heat pumps							
Model(s): KMF-140 DVR5							
Test matching indoor units form,no-duct: 2x KCIF-28 DN5.0+2x KCIF-45 DN5.0							
Outdoor side heat exchanger of air conditioner: air							
Indoor side heat exchanger of air conditioner: air							
If the heater is equipped with a supplementary heater: no							
Driver of compressor: electric motor							
Parameters shall be declared for the average heating season, parameters for the warmer and colder heating seasons are optional.							
Item	Symbol	Value	Unit	Item	Symbol	Value	Unit
Rated heating capacity	P _{rated,h}	14.00	kW	Seasonal space heating energy efficiency	η _{s,h}	181.0	%
Declared heating capacity for part load at indoor temperature 20°C and outdoor temperatures T _j				Declared coefficient of performance or gas utilisation efficiency/auxiliary energy factor for part load at given outdoor temperatures T _j			
T _j =-7°C	P _{dh}	8.85	kW	T _j =-7°C	COP _d	2.90	--
T _j =+2°C	P _{dh}	5.39	kW	T _j =+2°C	COP _d	4.50	--
T _j =+7°C	P _{dh}	3.60	kW	T _j =+7°C	COP _d	6.10	--
T _j =+12°C	P _{dh}	4.00	kW	T _j =+12°C	COP _d	7.80	--
T _{biv} =bivalent temperature	P _{dh}	10.00	kW	T _{biv} =bivalent temperature	COP _d	2.30	--
ToL=operation temperature	P _{dh}	10.00	kW	ToL =operation temperature	COP _d	2.30	--
Bivalent temperature	T _{biv}	-10	°C				
Degradation coefficient for heat pumps(**)	C _{dh}	0.25	--				
Power consumption in modes other than "active mode"				Supplementary heater			
Off mode	P _{OFF}	0.028	kW	Back-up heating capacity(*)	elbu	0	kW
Thermosat-off mode	P _{TO}	0.028	kW	Type of energy input			
Crankcase heater mode	P _{CK}	0.002	kW	Standby mode	P _{SB}	0.028	kW
Other items							
Capacity control	variable			For air-to-air heat pump: air flow rate, outdoor measured	--	5000	m³/h
Sound power level, outdoor	L _{WA}	71	dB				
GWP of the refrigerant		675	kg CO ₂ eq (100years)				
Contact details							
(*)							
(**)If C _{dh} is not determined by measurement, then the default degradation coefficient of heat pumps shall be 0.25.							
Where information relates to multi-split heat pumps, the test result and performance data may be obtained on the basis of performance of the outdoor unit, with a combination of indoor unit(s) recommended by the manufacturer or importer.							

KMF-160 DVR5

Cooling mode:

Information requirements for air-to-air conditioners								
Model(s): KMF-160 DVR5								
Test matching indoor units form,no-duct: 2x KCIF-36 DN5.0+2x KCIF-45 DN5.0								
Outdoor side heat exchanger of air conditioner: air								
Indoor side heat exchanger of air conditioner: air								
Type: compressor driven								
Driver of compressor: electric motor								
Item	Symbol	Value	Unit		Item	Symbol	Value	Unit
Rated cooling capacity	$P_{rated,c}$	15.50	kW		Seasonal space cooling energy efficiency	$\eta_{s,c}$	261.0	%
Declared cooling capacity for part load at given outdoor temperatures T_j and indoor 27/19°C (dry/wet bulb)					Declared energy efficiency ratio or gas utilisation efficiency/auxiliary energy factor for part load at given outdoor temperatures T_j			
$T_j=+35^\circ\text{C}$	P_{dc}	15.50	kW		$T_j=+35^\circ\text{C}$	EER_d	3.02	--
$T_j=+30^\circ\text{C}$	P_{dc}	11.40	kW		$T_j=+30^\circ\text{C}$	EER_d	4.60	--
$T_j=+25^\circ\text{C}$	P_{dc}	7.30	kW		$T_j=+25^\circ\text{C}$	EER_d	8.60	--
$T_j=+20^\circ\text{C}$	P_{dc}	5.20	kW		$T_j=+20^\circ\text{C}$	EER_d	12.00	--
Degradation co-efficient for air conditioners(*)								
	C_{dc}	0.25	--		Power consumption in modes other than "active mode"			
Off mode	P_{OFF}	0.028	kW		Crankcase heater mode	P_{CK}	0.002	kW
Thermosat-off mode	P_{TO}	0.005	kW		Standby mode	P_{SB}	0.028	kW
Other items								
Capacity control	variable				For air-to-air air conditioner: air flow rate, outdoor measured	--	5000	m^3/h
Sound power level, outdoor	L_{WA}	70	dB					
GWP of the refrigerant		675	$\text{kg CO}_2 \text{ eq (100years)}$					
Contact details								
(*)If C_{dc} is not determined by measurement, then the default degradation coefficient of heat pumps shall be 0.25.								
Where information relates to multi-split air conditioners, the test result and performance data may be obtained on the basis of performance of the outdoor unit, with a combination of indoor unit(s) recommended by the manufacturer or importer.								

KMF-160 DVR5

Heating mode:

Information requirements for heat pumps								
Model(s): KMF-160 DVR5								
Test matching indoor units form,no-duct: 2x KCIF-36 DN5.0+2x KCIF-45 DN5.0								
Outdoor side heat exchanger of air conditioner: air								
Indoor side heat exchanger of air conditioner: air								
If the heater is equipped with a supplementary heater: no								
Driver of compressor: electric motor								
Parameters shall be declared for the average heating season, parameters for the warmer and colder heating seasons are optional.								
Item	Symbol	Value	Unit		Item	Symbol	Value	Unit
Rated heating capacity	$P_{rated,h}$	15.50	kW		Seasonal space heating energy efficiency	$\eta_{s,h}$	173.0	%
Declared heating capacity for part load at indoor temperature 20°C and outdoor temperatures T_j					Declared coefficient of performance or gas utilisation efficiency/auxiliary energy factor for part load at given outdoor temperatures T_j			
$T_j=-7^\circ\text{C}$	P_{dh}	9.73	kW		$T_j=-7^\circ\text{C}$	COP_d	2.90	--
$T_j=+2^\circ\text{C}$	P_{dh}	5.92	kW		$T_j=+2^\circ\text{C}$	COP_d	3.90	--
$T_j=+7^\circ\text{C}$	P_{dh}	4.00	kW		$T_j=+7^\circ\text{C}$	COP_d	6.75	--
$T_j=+12^\circ\text{C}$	P_{dh}	3.90	kW		$T_j=+12^\circ\text{C}$	COP_d	8.50	--
T_{biv} =bivalent temperature	P_{dh}	11.00	kW		T_{biv} =bivalent temperature	COP_d	2.20	--
T_{OL} =operation temperature	P_{dh}	11.00	kW		T_{OL} =operation temperature	COP_d	2.20	--
Bivalent temperature	T_{biv}	-10	°C					
Degradation coefficient for heat pumps(**)								
	C_{dh}	0.25	--		Supplementary heater			
Power consumption in modes other than "active mode"					Supplementary heater			
Off mode	P_{OFF}	0.028	kW		Back-up heating capacity(*)	e_{lbu}	0	kW
Thermosat-off mode	P_{TO}	0.028	kW		Type of energy input			
Crankcase heater mode	P_{CK}	0.002	kW		Standby mode	P_{SB}	0.028	kW
Other items								
Capacity control	variable				For air-to-air heat pump: air flow rate, outdoor measured	--	5000	m ³ /h
Sound power level, outdoor	LWA	72	dB					
GWP of the refrigerant		675	kg CO ₂ eq (100years)					
Contact details								
(*)								
(**)If C_{dh} is not determined by measurement, then the default degradation coefficient of heat pumps shall be 0.25.								
Where information relates to multi-split heat pumps, the test result and performance data may be obtained on the basis of performance of the outdoor unit, with a combination of indoor unit(s) recommended by the manufacturer or importer.								

Fan Types	Axial fan		
Directive (or Standard) for Regulation		ErP Directive 2009/125/EC COMMISSION REGULATION (EU) No 327/2011	
Model Name	ZKSN-200-10-4L+ZL-580*200*12-3N	Rev.	
Prepare by			

Specified Information of Fan:

No.	Information Item	Comment
1	$\eta_{\text{target}} =$	29.41%
2	Overall efficiency (η_e) =	33.44%
3	Pass or not (Criteria: $\eta_e \geq \eta_{\text{target}}$)	Pass
4	Measurement category (A-D)	A
5	Efficiency category (static or total)	Static
6	Efficiency grade at optimum energy efficiency point	N =42.6
7	VSD is integrated within the fan	YES
8	Year of Manufacture	Ref. to the Unit Nameplate
9	Manufacturer's name and place of manufacture	Ref. to the Unit Nameplate
10.1	Rated motor power input(s) (kW), at optimum energy efficiency	0.211
10.2	Flow rate(s) at optimum energy efficiency (m ³ /h)	4891
10.3	Pressure(s) at optimum energy efficiency (Pa)	50
11	Rotations per minute (R.P.M) at the optimum energy efficiency point	800r/min
12	Specific ratio	1.001
13	Information relevant for facilitating disassembly, recycling or disposal at end-of-life	all materials can be recycled
14	Information relevant to minimize impact on the environment and ensure optimal life expectancy as regards installation, use and maintenance of the fan	For installation, the clearance of 500 mm shall be kept from inlet
15	Description of additional items used when determining the fan energy efficiency, such as ducts, that are not described in the measurement category and not supplied with the fan.	Measurement category A, fan is free inlet and outlet conditions
16	Motor manufacturer	GUANGDONG WELLING MOTOR MANUFACTURING CO.,LTD.

Fan Types	Axial fan		
Directive (or Standard) for Regulation	ErP Directive 2009/125/EC COMMISSION REGULATION (EU) No 327/2011		
Model Name	ZKSN-200-10-4L+ZL-580*200*12-3N	Rev.	
Prepare by			

Specified Information of Fan:

No.	Information Item	Comment
1	$\eta_{\text{target}} =$	29.23%
2	Overall efficiency (η_e) =	36.14%
3	Pass or not (Criteria: $\eta_e \geq \eta_{\text{target}}$)	Pass
4	Measurement category (A-D)	A
5	Efficiency category (static or total)	Static
6	Efficiency grade at optimum energy efficiency point	N =45.3
7	VSD is integrated within the fan	YES
8	Year of Manufacture	Ref. to the Unit Nameplate
9	Manufacturer's name and place of manufacture	Ref. to the Unit Nameplate
10.1	Rated motor power input(s) (kW), at optimum energy efficiency	0.198
10.2	Flow rate(s) at optimum energy efficiency (m ³ /h)	4886
10.3	Pressure(s) at optimum energy efficiency (Pa)	50
11	Rotations per minute (R.P.M) at the optimum energy efficiency point	800r/min
12	Specific ratio	1.001
13	Information relevant for facilitating disassembly, recycling or disposal at end-of-life	all materials can be recycled
14	Information relevant to minimize impact on the environment and ensure optimal life expectancy as regards installation, use and maintenance of the fan	For installation, the clearance of 500 mm shall be kept from inlet
15	Description of additional items used when determining the fan energy efficiency, such as ducts, that are not described in the measurement category and not supplied with the fan.	Measurement category A, fan is free inlet and outlet conditions
16	Motor manufacturer	Jiangsu Shangqi Group Co., Ltd.

Fan Types	Axial fan		
Directive (or Standard) for Regulation		ErP Directive 2009/125/EC COMMISSION REGULATION (EU) No 327/2011	
Model Name	ZKSN-200-10-3L+ZL-580*200*12-3N	Rev.	
Prepare by			

Specified Information of Fan:

No.	Information Item	Comment
1	$\eta_{\text{target}} =$	30.26%
2	Overall efficiency (η_e) =	33.39%
3	Pass or not (Criteria: $\eta_e \geq \eta_{\text{target}}$)	Pass
4	Measurement category (A-D)	A
5	Efficiency category (static or total)	Static
6	Efficiency grade at optimum energy efficiency point	N =42.1
7	VSD is integrated within the fan	YES
8	Year of Manufacture	Ref. to the Unit Nameplate
9	Manufacturer's name and place of manufacture	Ref. to the Unit Nameplate
10.1	Rated motor power input(s) (kW), at optimum energy efficiency	0.288
10.2	Flow rate(s) at optimum energy efficiency (m^3/h)	5615
10.3	Pressure(s) at optimum energy efficiency (Pa)	60
11	Rotations per minute (R.P.M) at the optimum energy efficiency point	900r/min
12	Specific ratio	1.001
13	Information relevant for facilitating disassembly, recycling or disposal at end-of-life	all materials can be recycled
14	Information relevant to minimize impact on the environment and ensure optimal life expectancy as regards installation, use and maintenance of the fan	For installation, the clearance of 500 mm shall be kept from inlet
15	Description of additional items used when determining the fan energy efficiency, such as ducts, that are not described in the measurement category and not supplied with the fan.	Measurement category A, fan is free inlet and outlet conditions
16	Motor manufacturer	GUANGDONG WELLING MOTOR MANUFACTURING CO.,LTD.

Fan Types	Axial fan		
Directive (or Standard) for Regulation	ErP Directive 2009/125/EC COMMISSION REGULATION (EU) No 327/2011		
Model Name	ZKSN-200-10-3L+ZL-580*200*12-3N	Rev.	
Prepare by			

Specified Information of Fan:

No.	Information Item	Comment
1	$\eta_{\text{target}} =$	30.32%
2	Overall efficiency (η_e) =	35.31%
3	Pass or not (Criteria: $\eta_e \geq \eta_{\text{target}}$)	Pass
4	Measurement category (A-D)	A
5	Efficiency category (static or total)	Static
6	Efficiency grade at optimum energy efficiency point	N =43.3
7	VSD is integrated within the fan	YES
8	Year of Manufacture	Ref. to the Unit Nameplate
9	Manufacturer's name and place of manufacture	Ref. to the Unit Nameplate
10.1	Rated motor power input(s) (kW), at optimum energy efficiency	0.294
10.2	Flow rate(s) at optimum energy efficiency (m ³ /h)	5448
10.3	Pressure(s) at optimum energy efficiency (Pa)	65
11	Rotations per minute (R.P.M) at the optimum energy efficiency point	900r/min
12	Specific ratio	1.001
13	Information relevant for facilitating disassembly, recycling or disposal at end-of-life	all materials can be recycled
14	Information relevant to minimize impact on the environment and ensure optimal life expectancy as regards installation, use and maintenance of the fan	For installation, the clearance of 500 mm shall be kept from inlet
15	Description of additional items used when determining the fan energy efficiency, such as ducts, that are not described in the measurement category and not supplied with the fan.	Measurement category A, fan is free inlet and outlet conditions
16	Motor manufacturer	Jiangsu Shangqi Group Co., Ltd.

1612700005968 V.A



Kaysun
by frigicoll

MAIN OFFICE

Blasco de Garay, 4-6
08960 Sant Just Desvern
(Barcelona)
Tel. +34 93 480 33 22
<http://www.frigicoll.es/>
<http://www.kaysun.es/en/>

MADRID

Senda Galiana, 1
Polígono Industrial Coslada
Coslada (Madrid)
Tel. +34 91 669 97 01
Fax. +34 91 674 21 00
madrid@frigicoll.es